

AUR381Z

Asymmetry and undervoltage relays for 3(N)AC systems without external supply voltage



AUR381Z

Device features

- Monitoring of 3(N)AC systems for asymmetry, undervoltage and phase failure
- Without external supply voltage
- Adjustable response value
5...15 % / 0.7...0.95 x U_n
- Response delay 0.5...5 s
- Power On LED, Alarm LED
- Alarm relay with two potential-free changeover contacts

Product description

The relay of the AUR381Z series is designed to monitor 3(N)AC systems for asymmetry, undervoltage and phase failure. External supply voltage is not required. The internal supply voltage is electrically isolated from the system. Special input transformers attenuate of interferences from the system. An integrated protective circuit is provided for use in systems with interferences.

Typical applications

- Monitoring of the power supply of motors or electrical installations
- Monitoring of asymmetrically loaded systems

Function overvoltage relay

When supply voltage is applied, the alarm relay works in N/C operation (relay energized). When the difference of the phase-to-phase voltage (asymmetry) exceeds the set response value, the alarm relay deenergizes and the alarm LED "U_n" goes out.

When the voltage falls below the response value threshold for undervoltage, the alarm relay behaviour is the same. If the measured quantity falls below or exceeds the release values, the alarm relay returns to its original state.

Note

False asymmetry alarms resulting from operational measurement errors can be suppressed by setting a time delay. In case of complete system failure, the time delay is not effective, except for the device operating time. If the delay function is to be maintained in case of complete system failure, the energy backup SP100 is recommended to be used.

Technical data asymmetry and undervoltage relay AUR381Z

Insulation coordination acc. to IEC 60664-1

Rated insulation voltage	AC 630 V
Rated impulse voltage/pollution degree	6 kV/3

Supply voltage

Supply voltage U_s	none
Power consumption	≤ 5 VA

Measuring circuit

Nominal system voltage U_n	see ordering information
Operating range of U_n	0.5...1.3 x U_n
Frequency f_n	50...60 Hz
Response value asymmetry	5...15 % (L-L)
Response value undervoltage	0.7...0.95 x U_n
Response delay t_v	0.5...5 s
Hysteresis	approx. 2 %

Switching elements

Number of changeover contacts	1 x 2
Operating principle	N/C operation
Electrical service life, number of cycles	12000
Contact class IEC 60255 Part 0-20	IIB
Rated contact voltage	AC 250 V/DC 300 V
Limited making capacity	AC/DC 5 A
Breaking capacity	2 A, AC 230 V, cos phi 0.4 0.2 A, DC 220 V, L/R = 0.04 s

Environment / EMC

EMC immunity	acc. to IEC 61000-6-2
EMC emission	acc. to IEC 61000-6-4
Shock resistance IEC 60068-2-27 (during operation)	15 g/11 ms
Bumping IEC 60068-2-29 (during transport)	40 g/6 ms
Vibration resistance IEC 60068-2-6 (during operation)	1 g / 10...150 Hz
Vibration resistance IEC 60068-2-6 (during transport)	2 g / 10...150 Hz
Ambient temperature, during operation	-10...+50 °C
Ambient temperature, during storage	-20...+70 °C
Climatic class acc. to IEC 60721-3-3	3K5 (except condensation and formation of ice)

Other

Operating mode	continuous operation
Mounting	any position
Connection	Flat terminals with self-lifting clamp washers
Connection properties	
single wire	2 x (1...1.5) mm ²
flexible with end ferrules	2 x (0.75...1.5) mm ²
Degree of protection, internal components (IEC 60529)	IP30
Degree of protection, terminals/with terminal covers (IEC 60529)	IP10/IP20
Screw fixing	refer to dimension diagram
DIN rail mounting acc. to	IEC 60715
Flammability class	UL94V-0
Product standard	IEC 60266-6
Operating manual	BP302003
Weight	≤ 700 g



Wiring diagram

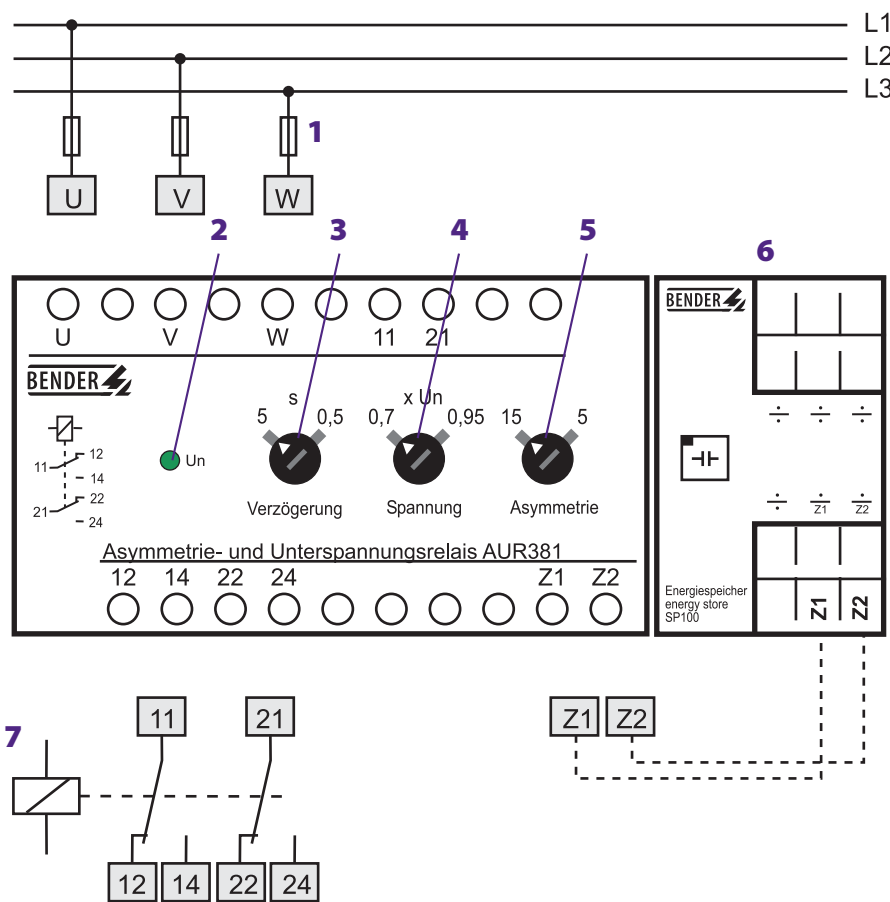

- 1 - 6 A fuse
- 2 - Power On LED "U_n", goes out in the event of asymmetry, undervoltage and system failure.
- 3 - Adjustable response delay "s"
- 4 - Adjustable response value for undervoltage "xU_n"
- 5 - Adjustable response value for asymmetry
- 6 - Energy backup SP100
Energy backup to maintain the delay function for max. 5 s in case of complete system failure (option).
- 7 - Alarm relay in N/C operation

3.2

Ordering information		
Type	Nominal system voltage U _n	Art. No.
AUR381Z	3(N)AC 100 V	B 935 603
AUR381Z	3(N)AC 110 V	B 935 507
AUR381Z	3(N)AC 400 V	B 935 631
AUR381Z	3(N)AC 440 V	B 935 630
AUR381Z	3(N)AC 500 V	B 935 053
AUR381Z	3(N)AC 690 V	B 935 068
SP100	Energy backup	B 935 700

Dimension diagram X200

Dimensions in mm

