

CME420

Multi-functional current relay for AC currents



CME420

Device features

- Undercurrent and overcurrent monitoring in AC systems of 0.1...16 A
- Indirect current monitoring with standard current transformers, $\times/5$ A...999 A
- Different monitoring functions selectable $< I$, $> I$ or $< I/> I$
- Start-up delay, response delay, delay on release
- Adjustable switching hysteresis
- r.m.s. value measurement (AC)
- Digital measured value display via multi-functional LC display
- Power On LED, Alarm LEDs: Alarm 1, Alarm 2
- Measured value memory for operating value
- Continuous self monitoring
- Internal test/rest button
- Two separate alarm relays (gold-plated relay contacts), one changeover contact each
- N/C or N/O operation and fault memory behaviour selectable
- Password protection for device setting
- Sealable transparent cover
- Two-module enclosure (36 mm)
- RoHS-compliant

Approvals



Under development!

Product description

The relays of the CME420 series monitor undercurrent and overcurrent in AC systems as well as the current between two threshold values (window discriminator function). The currents are measured as r.m.s. values (AC). The currently measured value is continuously shown on the LC display. The measured value leading to the activation of the alarm relays will be stored. Due to adjustable delay times, installation-specific characteristics, such as device-specific making currents, short-time current changes etc. can be considered. Current measurement is possible either directly or indirectly via standard current transformers ($\times/5$ A). External supply voltage is required.

Typical applications

- Current consumption of motors, such as pumps, elevators, cranes
- Monitoring of lighting circuits, heating circuits, charging stations
- Monitoring of emergency lighting
- Monitoring of screw conveyors, e.g. in sewage plants
- Dust removal in wood working

Function

Once the supply voltage is applied, the start-up delay "t" is activated. Measured values changing during this time do not influence the switching state of the alarm relays.

The devices provide two separately adjustable measuring channels (overcurrent/undercurrent). When the measuring quantity exceeds the response value (Alarm 1) or falls below the response value (Alarm 2), the time of the response delays "t_{on 1/2}" begins. When the response delay has elapsed, the alarm relays switch and the alarm LEDs light. When the measuring value exceeds or falls below the release value (response value plus hysteresis) after the alarm relays have switched, the selected release delay "t_{off}" begins. When "t_{off}" has elapsed, the alarm relays switch back to their original state. When the fault memory is activated, the alarm relays remain in alarm state until the reset button R is pressed.

Dimension diagram XM420

Dimensions in mm

Open the front plate cover in direction of arrow!

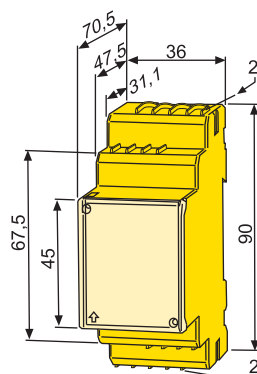

Screw fixing

Note: The upper mounting clip must be ordered separately (see ordering information).

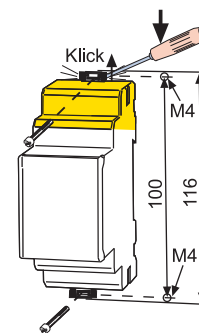



Operating elements

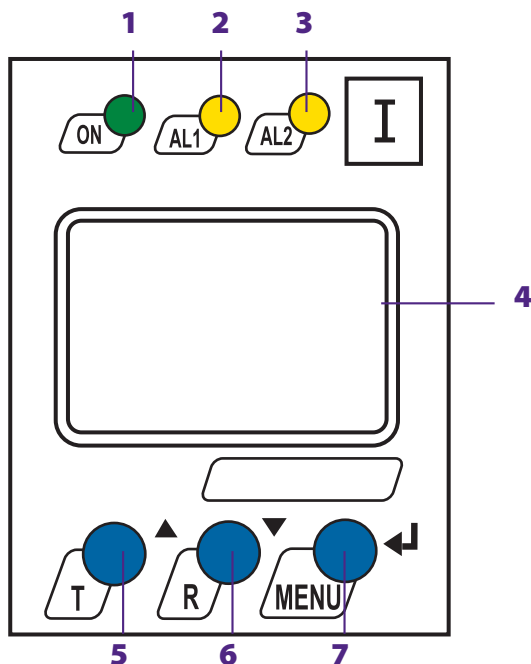

- 1 - Power On LED "ON" (green); Lights when supply voltage is applied and flashes in the event of system fault alarm.
- 2 - Alarm LED "AL1" (yellow): lights when the set response value is exceeded and flashes in the event of system fault alarm.
- 3 - Alarm LED "AL2" (yellow): lights when the value falls below the set response value and flashes in the event of system fault alarm.
- 4 - Multi-functional LC display.
- 5 - Test button "T": To call up the self test.
Arrow up key: Parameter change, to move up in the menu.
- 6 - Reset button "R": To delete saved alarms.
Arrow down key: parameter change, to move down in the menu.
- 7 - MENU key: to call up the menu system.
Enter key: to confirm parameter change.
Press ESC: key > 1.5 seconds.

Wiring diagram

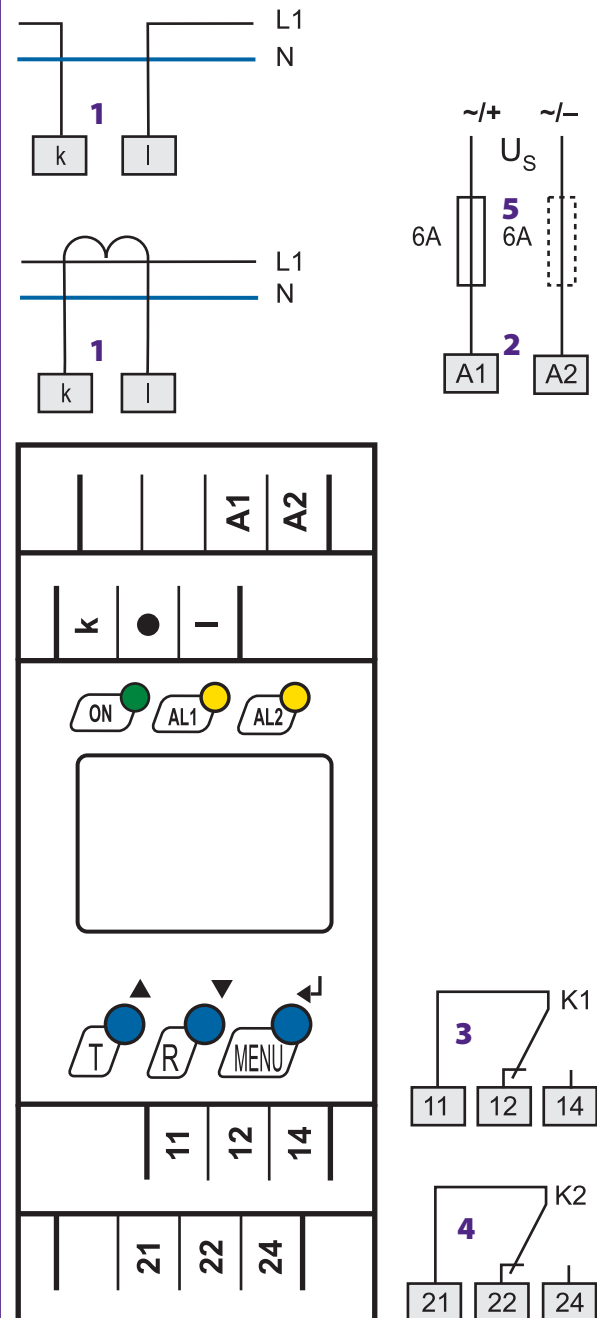

- 1 - Connection to the system/load being monitored
- 2 - Supply voltage U_s (see ordering information)
- 3 - Alarm relay K1: Programmable for $<I/>I$ /TEST/ERROR alarm
- 4 - Alarm relay K2: Programmable for $<I/>I$ /TEST/ERROR alarm
- 5 - Line protection according to IEC 60364-4-43
A 6 A fuse is recommended. is recommended. If being supplied from an IT system, both lines have to be protected by a fuse.

3.5

Timing diagram current monitoring

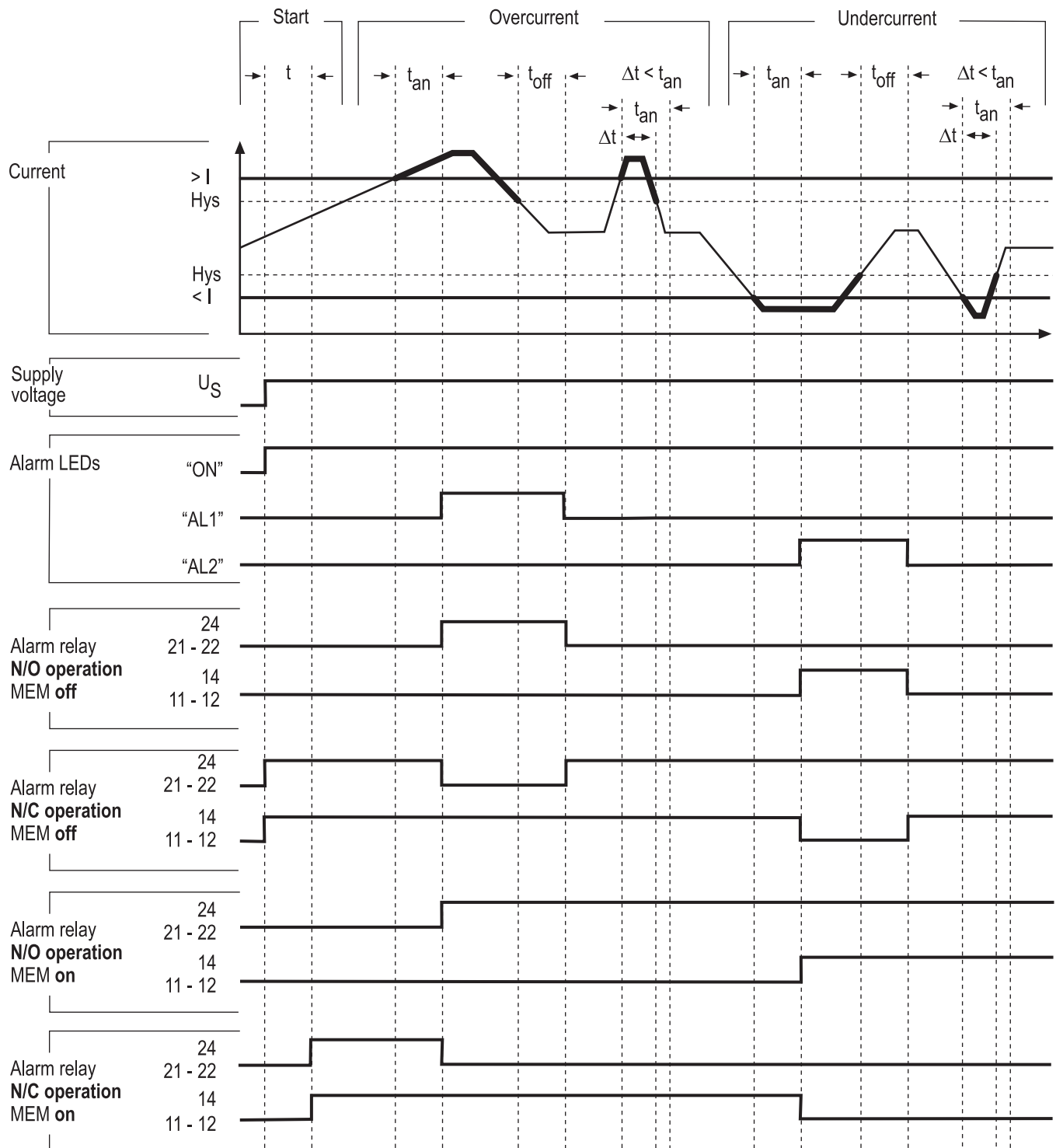

- t - Start-up delay
- t_{an} - Response time
Operating time (t_{ae}) + Response delay ($t_{an 1/2}$)
- t_{off} - Delay on release

3.5

Technical data undercurrent and overcurrent relay CME420

Insulation coordination acc. to IEC 60664-1 / IEC 60664-3

Rated insulation voltage	250 V
Rated impulse voltage/pollution degree	2.5 kV / III
Protective separation (reinforced insulation) between (A1, A2) - (k, l) - (11, 12, 14) - (21, 22, 24)	
Maximum rated voltage of the system being monitored (conductor to be monitored directly connected)	
With protective separation	AC 230 V
Without protective separation	AC 400 V
Voltage test according to IEC 61010-1	2.21 kV

Supply voltage

Supply voltage U_s	see ordering information
Power consumption	≤ 3 VA

Measuring circuit

Rated frequency	42...460 Hz
Measuring range	AC 0.05...16 A
Overload capability, continuous	17.6 A
Overload capability < 1 s	40 A
Frequency display range	10...2000 Hz
Response values	
Undercurrent (alarm 2)	direct connection: AC 0.1...16 A (1 A)*
Overcurrent (alarm 1)	direct connection: AC 0.1...16 A (10 A)* current transformer x/5 A: 0.1 x n...999 A (10 A)*
Transformation ratio n	1...2000 (1)*
Relative percentage error in the range of 50/60 Hz	$\pm 3\% \pm 2$ digit
Relative percentage error in the range 40...460 Hz	$\pm 5\% \pm 2$ digit
Hysteresis	1...40% (15%)*

Specified time

Start-up delay t	0...99 s (0.5 s)*
Response delay t_{on1}	0...99 s (1 s)*
Response delay t_{on2}	0...99 s (0 s)*
Delay on release t_{off}	0...99 s (0.1 s)*
Operating time t_{ae}	≤ 70 ms
Response time t_{an}	$t_{an} = t_{ae} + t_{on1/2}$
Recovery time t_b	≤ 300 ms

Displays, memory

Display range measured value	AC 0.01...16 A x n
Operating error in the range of 50/60 Hz	$\pm 3\% \pm 2$ digit
Operating error in the range of 40...460 Hz	$\pm 5\% \pm 2$ digit
Measured-value memory for alarm value	data record measured values
Password	off / 0...999 (off)*
Fault memory alarm relay	on / off (on)*

Switching elements

Number of changeover contacts	2 relays with one changeover contact each				
Operating principle	N/C operation/ N/O operation (N/O operation)*				
Electrical service life	10.000 switching operations				
Contact data acc. to IEC 60947-5-1					
Utilization category	AC-13	AC-14	DC-12	DC-12	DC-12
Rated operational voltage	230 V	230 V	24 V	110 V	220 V
Rated operational current	5 A	3 A	1 A	0.2 A	0.1 A
Minimum contact load / gold-plated relay contacts	1 mA at AC/DC ≥ 10 V				

Environment / EMC

EMC	IEC 61326-1				
Operating temperature	-25...+55 °C				
Climatic class acc. to IEC 60721					
Stationary use (IEC 60721-3-3)	3K5 (except condensation and formation of ice)				
Transport (IEC 60721-3-2)	2K3 (except condensation and formation of ice)				
Long-time storage (IEC 60721-3-1)	1K4 (except condensation and formation of ice)				
Classification of mechanical conditions IEC 60721					
Stationary use (IEC 60721-3-3)					3M4
Transport (IEC 60721-3-2)					2M2
Long-time storage (IEC 60721-3-1)					1M3

Connection

Connection	push-wire terminals				
Connection properties:					
rigid					0.2...2.5 mm ² (AWG 24...14)
Flexible without ferrules					0.2...2.5 mm ² (AWG 24...14)
Flexible with ferrules					0.2...1.5 mm ² (AWG 24...16)
Stripping length	10 mm				
Opening force	50 N				
Test opening, diameter	2.1 mm				

Other

Operating mode	continuous operation				
Position of normal use	any				
Degree of protection, internal components (IEC 60529)	IP30				
Degree of protection, terminals (IEC 60529)	IP20				
Enclosure material	polycarbonate				
Flammability class	UL94V-0				
DIN rail mounting acc. to	IEC 60715				
Screw mounting	2 x M4 with mounting clip				
Product standard	IEC 61010-1 and according to IEC 60255-6				
Operating manual	TGH1400				
Weight	≤ 160 g				

() * factory setting

3.5

Ordering information

Type	Supply voltage U_s *	Measurement	Display range	Response value	Art. No.
CME420-D-1	DC 9.6...94 V / AC 42...460 Hz 16...72 V	directly/via current transformer x/5A	0.1...16 A / 5...999 A	0.1...16 A x n	B 7306 0001
CME420-D-2	DC 70...300 V / AC 42...460 Hz 70...300 V	directly/via current transformer x/5A	0.1...16 A / 5...999 A	0.1...16 A x n	B 7306 0002

Device version with screw-type terminals on request.

* absolute values

Accessories

Type	Art. No.
Mounting clip for screw fixing (1 piece per device)	B 9806 0008