

ISOMETER® IR1575

Insulation monitoring device for unearthed AC/3(N)AC systems up to 480 V and DC systems up to 480 V



ISOMETER® IR1575

**Insulation monitoring device
for unearthed AC/3(N)AC systems
up to 480 V and DC systems up to 480 V**



ISOMETER® IR1575

Device features

- Insulation monitoring for unearthed AC, AC/DC systems 0...480 V and DC systems 0...480 V
- Two separately adjustable response values 2 kΩ...1 MΩ
- AMP measurement method
- Automatic adaptation to the system leakage capacitance
- LEDs: Alarm 1/Alarm 2
- Fault memory behaviour, selectable
- Connection monitoring system/earth
- Test and reset button
- Connection external test and reset button
- Two separate alarm relays with one changeover contact each
- N/O or N/C operation, selectable
- Backlit LC display
- Self monitoring with automatic alarm
- Plug-in terminals
- Enclosure for door mounting 96 x 96 mm

Approvals



Product description

The ISOMETER® of the IR1575 series monitor the insulation resistance of unearthed main circuits (IT systems) AC, 3(N)AC 0...480 V resp. DC 0... 480 V.

The AMP measurement method allows the Isometers to be used in systems with directly connected DC components. Taking the system leakage capacitances into account, the IR1575 automatically adapts itself to the existing system conditions in order to optimise the measuring time. An external supply voltage allows de-energised systems to be monitored too.

Please note that the frequency range of the IR1575 is limited to DC, 30...420 Hz. For use in systems containing variable-speed drives, we recommend to use the IRDH275/375 version.

Application

- AC or AC/DC main circuits
- AC/DC main circuits with directly connected DC components
- UPS systems, battery systems
- Heaters with phase control
- Installations including switch-mode power supplies

Function

When the insulation resistance between the system conductors and earth falls below the set response value, the alarm relays switch and the alarm LEDs light up. Two separately adjustable response values/alarm relays allow a distinction to be made between prewarning and alarm. The measured value is indicated on the LC display. The fault message can be stored. The fault memory can be reset by pressing the reset button. By pressing the test button, the function of the device as well as the connections to system and earth can be tested. When a fault occurs during this test, it will be signalled by alarm relay K2. The parameterisation of the device can be carried out via the LC display or the function buttons integrated in the front plate.

Measurement method



The ISOMETER®s of the IR1575 use the AMP measurement method.

Standards

The ISOMETER® of the IR1575 series complies with the requirements of the device standards: DIN EN 61557-8 (VDE 0413-8), EN 61557-8, IEC 61557-8, IEC 61326-2-4, DIN EN 60664-1 (VDE 0110-1), DIN EN 60664-3 (VDE 0110-3), ASTM F1669M-96 (2007), ASTM F1207M-96 (2007)

Wiring diagram – Operating elements

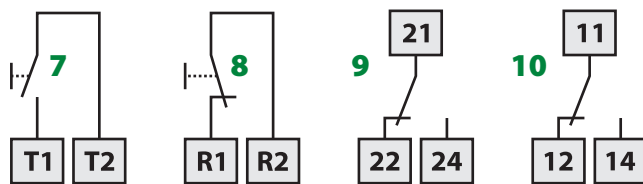
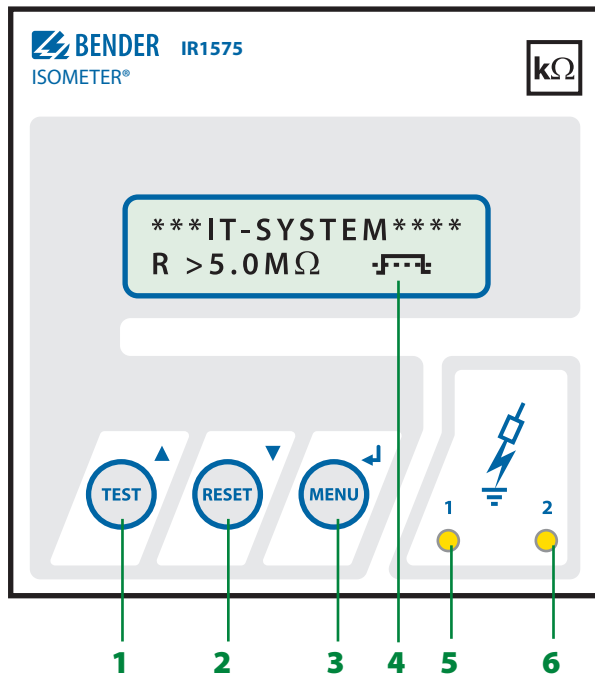

- 1 - "TEST" button: to call up the self test
Arrow up button: Parameter changes, scroll
- 2 - "RESET" button: to delete alarm and fault messages
Arrow down button: Parameter changes, scroll
- 3 - "MENU" button: to call up the menu system
Enter button: to confirm parameter changes
- 4 - LC display 2 x 16 characters
- 5 - Alarm LED "1" lights: insulation fault, first warning level reached
- 6 - Alarm LED "2" lights: insulation fault, second warning level reached
- 7 - External test button "T1/T2" (N/O contact)
- 8 - External reset button "R1/R2" (N/C contact or wire jumper).
When the terminals are open, the fault message will not be stored.
- 9 - Alarm relay. Alarm 2
- 10 - Alarm relay. Alarm 1

Wiring diagram – Mains connection

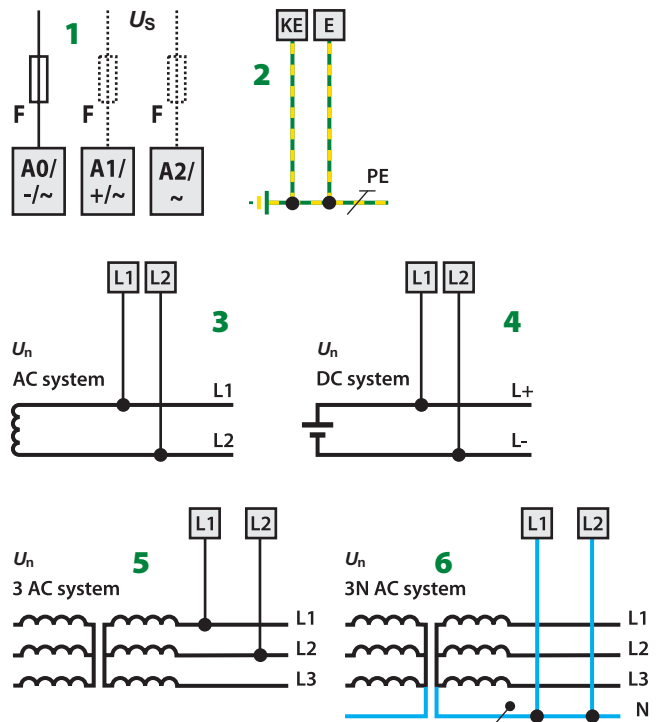
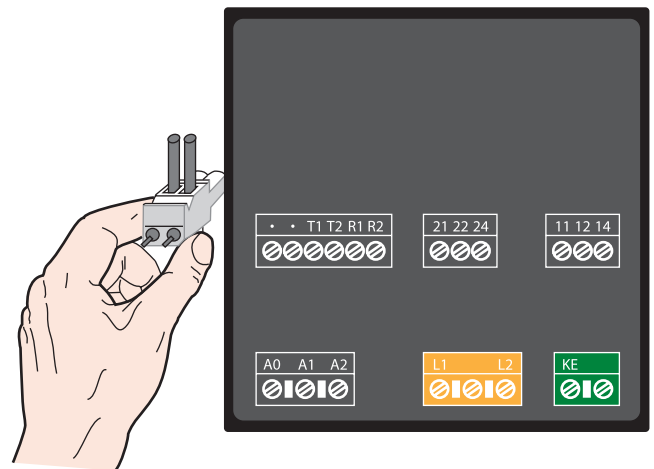

- 1 - Supply voltage U_s (see nameplate) 6 A fuse protection recommended:
A0 - A1 = AC 88 ... 264 V, DC 77 ... 286 V
A0 - A2 = AC 340 ... 460 V
- 2 - Separate connection of E and KE to PE
- 3 - Connection to the AC system to be monitored:
connect terminals L1, L2 to conductor L1, L2.
- 4 - Connection to the DC system to be monitored:
Connect terminal L1 to conductor L+, terminal L2 to conductor L-
- 5,6 - Connection to the 3AC system to be monitored:
Connect the terminals L1, L2 to neutral conductor N or terminals L1, L2 to conductor L1, L2.

Technical data

Insulation coordination acc. to IEC 60664-1

Rated insulation voltage	AC 500 V
Rated impulse withstand voltage/pollution degree	4 kV/3

Voltage ranges

Nominal system voltage U_n	AC, 3(N)AC 0...480 V, DC 0...480 V
Nominal frequency f_n	DC, 30...420 Hz
Supply voltage U_S	see ordering information
Power consumption	≤ 5 VA

Response values

Response value R_{an1} (Alarm 1)	2 kΩ...1 MΩ
Response value R_{an2} (Alarm 2)	2 kΩ...1 MΩ
Relative uncertainty	0...+20 %/min. +2 kΩ
Response time t_{an} at $R_F = 0.5 \times R_{an}$ and $C_e = 1 \mu\text{F}$	≤ 5 s
Hysteresis	25%

Measuring circuit

Measuring voltage U_m	±20 V
Measuring current I_m (at $R_F = 0 \Omega$)	≤ 170 μA
Internal DC resistance R_i	≥ 119 kΩ
Impedance Z_i at 50 Hz	≥ 14 kΩ
Permissible extraneous DC voltage U_{fg}	≤ DC 680 V
Permissible system leakage capacitance	≤ 60 μF

Displays

Display	backlit LC display
Characters (number of characters, height)	2 x 16 (4.5 mm)
Display range, measured value	1 kΩ...5 MΩ
Operating uncertainty (1...10 kΩ)	± 1 kΩ
Operating uncertainty (10 kΩ...5 MΩ)	± 10 %

Outputs

Test and reset button	internal/external
-----------------------	-------------------

Switching elements

Number of switching elements	2 x 1 changeover contact
Operating principle	N/C operation/N/O operation
Factory setting	N/O operation
Contact class	IIB (IEC 60255-0-20)
Rated contact voltage	AC 250 V/DC 300 V
Making capacity	AC/DC 5 A
Breaking capacity	2 A, AC 230 V, cos phi 0.4 0.2 A, DC 220 V, L/R = 0.04 s
Contact rating at DC 24 V	≥ 2 mA (50 mW)

Environment

Shock resistance IEC 60068-2-27 (device in operation)	15 g/11 ms
Bumping IEC 60068-2-29 (transport)	40 g/6 ms
Vibration resistance IEC 60068-2-6 (device in operation)	1 g/10...150 Hz
Vibration resistance IEC 60068-2-6 (transport)	2 g/10...150 Hz
Ambient temperature (during operation)	-10...+55 °C
Ambient temperature (during storage)	-40...+70 °C
Climatic class acc. to DIN IEC 60721-3-3	3K5

Connection

Connection	plug-in terminals
Connection properties	
rigid/flexible	0.2.../4/0.2...2.5 mm ²
flexible with ferrules without/with plastic sleeve	0.25...2.5 mm ²
Conductor sizes (AWG)	24...12
Tightening torque	0.5...0.6 Nm (4.3...5.3 lb-in)

Other

Operating mode	continuous operation
Mounting position	display-oriented
Degree of protection, internal components (DIN EN 60529)	IP30
Degree of protection, terminals (DIN EN 60529)	IP20
Mounting	panel mounting
Flammability class	UL94 V-2
Operating manual	TGH1370
Weight	≤ 400 g

Measuring time

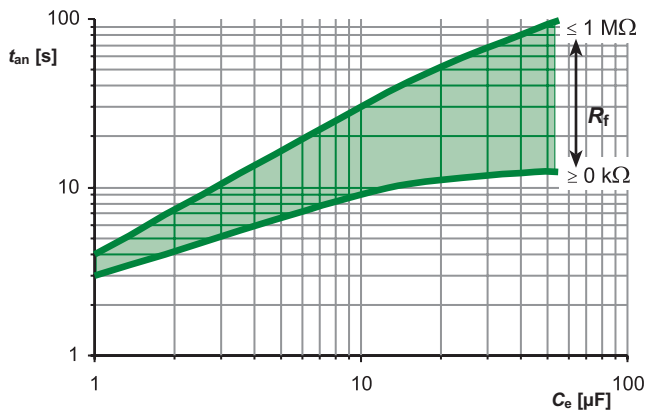

Dimension diagram

Dimensions in mm

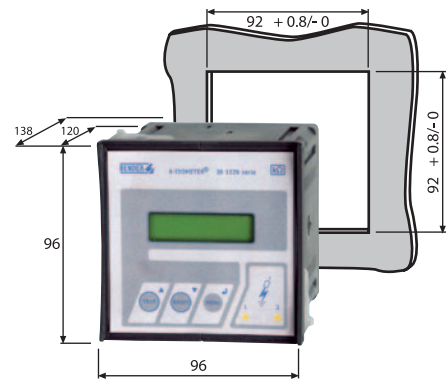

Ordering information

Design	Supply voltage $U_S^{1)}$		Type	Art. No.
	AC	DC		
Standard	88...264 V 340...460 V	77...286 V	IR1575-435	B 9106 4000
Increased shock and vibration resistance	88...264 V 340...460 V	77...286 V	IR1575W-435	B9106 4000W

¹⁾ Absolute values



Bender GmbH & Co. KG

P.O. Box 1161 • 35301 Grünberg • Germany
Londorfer Straße 65 • 35305 Grünberg • Germany
Tel.: +49 6401 807-0 • Fax: +49 6401 807-259
E-Mail: info@bender-de.com • www.bender-de.com

BENDER Group