

Residual current monitor

RCM471LY

Residual current monitor
for TN and TT systems
(AC and pulsating DC currents)

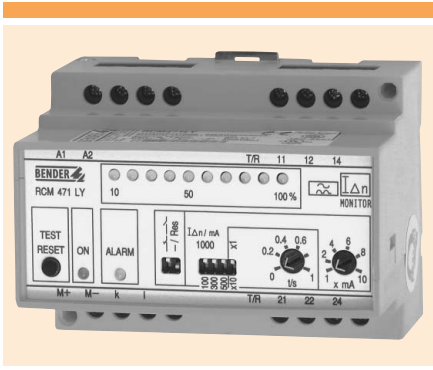

RCM471LY

Device features

- External measuring current transformer
- Response values, adjustable
300 mA... 10 A 40...400 Hz
- Time delay, adjustable 0... 10 s
- Alarm relay with two voltage free
changeover contacts
- N/O / N/C operation, selectable
- Fault memory, selectable
- Combined test and reset button
- Connection for external test and reset
button
- LED bar graph indicator $I_{\Delta n}$ 0... 100 %
- Connection external measuring
instrument $I_{\Delta n}$ 0... 100 %
- CT connection monitoring
- Transparent dust cover for ingress
protection
- Separate supply voltage
- Type A according to IEC 60755

Product description

The residual current monitor RCM471LY is designed for fault current respectively residual current monitoring in earthed systems (TN and TT systems) where an alarm is to be activated in case of a fault, but disconnection must be prevented. In addition, single conductors can be monitored, e.g. PE conductors, N-PE and PE-PAS (equipotential bonding bar) connections.

The measuring values are detected via flexible, wrap-around measuring current transformers, therefore the devices are nearly independent of the load current and nominal voltage of the system. The device can also be used for busbar systems, the measuring current transformer can be retrofitted.

Application

- Residual current monitoring in earthed two, three or four conductor systems (TN and TT systems)
- Current monitoring of single conductors de-energized under normal conditions
- Socket outlet circuits for devices which are operated unattended for a long time and which may not fail
- Alarm systems, safety devices
- Air conditioning systems, EDP systems
- Cooling equipment with valuable frozen goods
- Canteen kitchen
- Monitoring of earthed power supplies for stray currents, loads of N conductors

Function

The residual current is measured using an external, flexible measuring current transformer. When the current respectively the residual current exceeds the set response value, the alarm LED lights and the alarm relay switches after the expiry of the set response delay. The alarm messages can be stored. The fault memory can be reset by pressing the reset button. The function of the device can be tested using the test button.

The currently measured value in per cent related to the set response value is indicated on the LED bar graph indicator. The CT circuit is continuously monitored. In case of wire breakage the alarm relay switches and the alarm LED flashes.

Standards and regulations

The residual current monitor RCM471LY complies with the requirements of DIN EN 62020 (VDE 0663): 1999-07, IEC 62020: 2003-11.



Wiring diagram – system connection, external connections

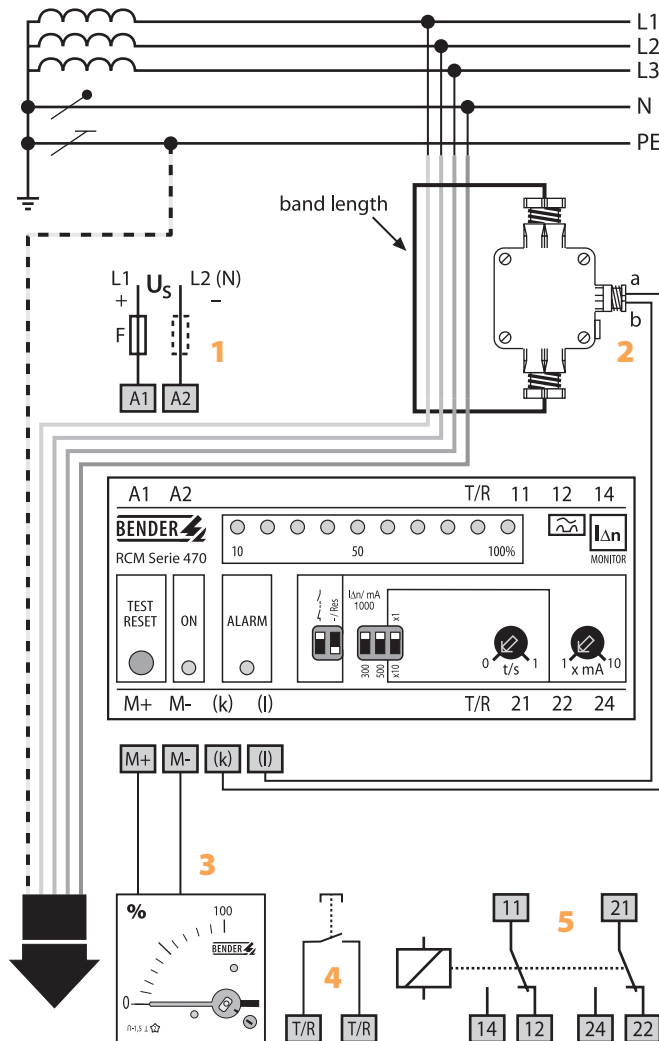

- 1 - Supply voltage U_s see ordering details, a 6 A fuse is recommended
- 2 - External, flexible, wrap-around measuring current transformer (see table "External measuring current transformers")
- 3 - External measuring instrument
- 4 - External test and reset button
- 5 - Alarm relay: switches when the fault current exceeds the response value and in case of interruption of the CT connection.

Note! Do not lead the PE conductor through the measuring current transformer!

Wiring diagram – frontplate

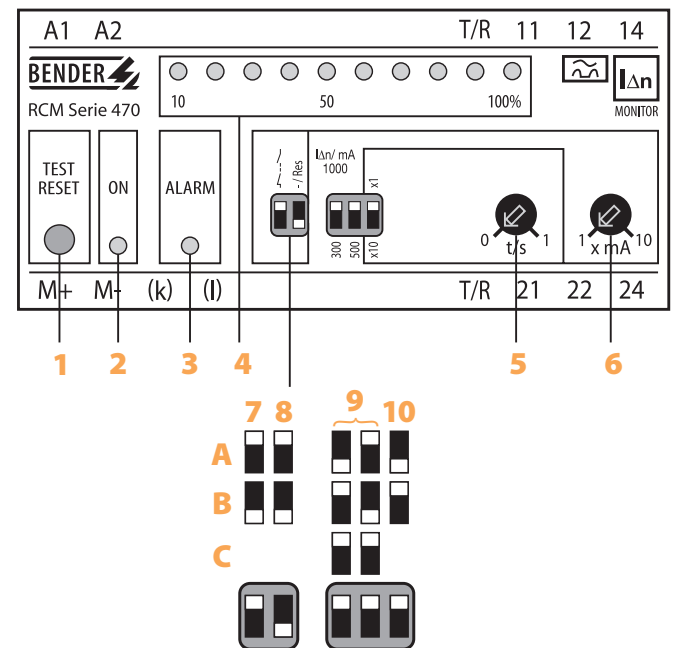

- 1 - Combined test and reset button: short-time pressing (< 1 s) = RESET; long-time pressing (> 2 s) = TEST
- 2 - Power ON LED
- 3 - Alarm LED: lights when the fault current exceeds the set response value and after the expiry of the response delay and flashes in case of CT interruption
- 4 - LED bar graph indicator: indicates the measuring value in per cent related to the set response value
- 5 - Adjustable response delay
- 6 - Adjustable response value

Setting of the DIP switches (white = switch position)

- 7 - Operating principle of the alarm relay
 - A - N/O operation
 - B - N/C operation
- 8 - Fault memory relay + LED
 - A - fault memory ON
 - B - fault memory OFF
- 9 - Setting of the response range
 - A - 300 mA
 - B - 500 mA
 - C - 1000 mA

} x 1...10
- 10 - Setting of the response delay
 - A - x 10
 - B - x 1

} 0...1 s

Technical data residual current monitor RCM471LY

Insulation coordination according to IEC 60664-1:

Rated voltage	AC 250 V
Rated impulse voltage / pollution degree	4 kV / 3

Voltage ranges

Supply voltage U_S	see ordering details
Operating range of U_S	0.85 ... 1.1 x U_S
Frequency range U_S	50 ... 400 Hz
Max. power consumption	3 VA

Measuring circuit / response values

Type of external CT	W500 ... W1000
Load	5,6 k Ω
Operating characteristics acc. to IEC 60755	type A
Rated residual operating current $I_{\Delta n}$	300 mA ... 10 A
Rated frequency	40 ... 400 Hz
Relative percentage error	0 ... -50 %
Response time t_{an} at $I_{\Delta n} = 1 \times I_{\Delta n} / t_v = 0$ s	< 250 ms
Response time t_{an} at $I_{\Delta n} = 5 \times I_{\Delta n} / t_v = 0$ s	≤ 20 ms
Response delay t_v , adjustable	0 ... 10 s
Hysteresis	approx. 25 % of the response value

Displays and LEDs

LED bar graph indicator	0 ... 100 %
LEDs	Power On, alarm

Inputs / outputs

Test / reset button	internal / external
Max. cable length external test / reset button	≤ 10 m
Current source for external measuring instrument / max. load	DC 0 ... 400 μ A / 12.5 k Ω
Connection to CT:	single wire ≥ 0.75 mm ² ; 0 ... 1 m single wire twisted ≥ 0.75 mm ² ; 1 ... 10 m shielded cable ≥ 0.6 mm ² , cable type e.g. J-Y(ST)Y 2 x 0.6: 10 ... 40 m (shield on one side connected to PE)

Switching elements

Switching elements	2 changeover contacts
Operating principle, adjustable	N/C or N/O operation
Electrical endurance / number of cycles	12000
Rated contact voltage	AC 250 V / DC 300 V
Making capacity	AC / DC 5 A
Breaking capacity	2 A, AC 230 V, cos phi = 0.4 0.2 A, DC 220 V, L / R = 0.04 s
Fault memory, adjustable	ON / OFF

General data

EMC immunity	acc. to EN 61543
EMC emission	acc. to EN 61000-6-4
Shock resistance IEC 60068-2-27 (device in operation)	15 g / 11 ms
Bumping IEC 60068-2-29 (during transport)	40 g / 6 ms
Vibration resistance IEC 60068-2-6 (device in operation)	1 g / 10 ... 150 Hz
Vibration resistance IEC 60068-2-6 (device out of operation)	2 g / 10 ... 150 Hz
Ambient temperature (during operation)	-10 °C ... +55 °C
Storage temperature range	-40 °C ... +70 °C
Climatic class according to DIN IEC 60721-3-3	3K5
Operating mode	continuous operation
Position	any position
Connection	screw terminals
Cross sectional area of connecting cable	
rigid / flexible	0.2 ... 4 mm ² / 0.2 ... 2.5 mm ²
Flexible with ferrules without / with plastic collar	0.25 ... 2.5 mm ²
Conductor sizes (AWG)	24 ... 12
Degree of protection, internal components (DIN EN 60529)	IP30
Degree of protection, terminals (DIN EN 60529)	IP20
Enclosure	X470
Enclosure, material	polycarbonate
Screw fixing	2 x M4
DIN rail mounting according to	DIN EN 60715 / IEC 60715
Flammability class	UL94V-0
Instruction leaflet No.	401007
Weight	approx. 350 g

Ordering details residual current monitor RCM471LY

Type	Response range $I_{\Delta n}$	Rated frequency	Time delay	Measuring current transformer	Indication	Fault memory	Supply voltage U_S	Art. No.
RCM471LY	300 mA ... 10 A	40 ... 400 Hz	0 ... 10 s	W500 ... W1000	internal / external	selectable	AC 230 V	B 9401 2054

Accessories

External measuring current transformer

Type	Length (mm)	Art. No.
W1000	1000	B 911 711

Other types on request.

External measuring instrument

Type	Indication	Size (mm)	Art. No.
9604-4241	0...100 %	96 x 96	B 986 807

Measuring transducer

Type	Input	Output	Art. No.
RK170	0...400 μ A	0...10 V 0/4...20 mA	B 9804 1500

Dimension diagram, enclosure X470

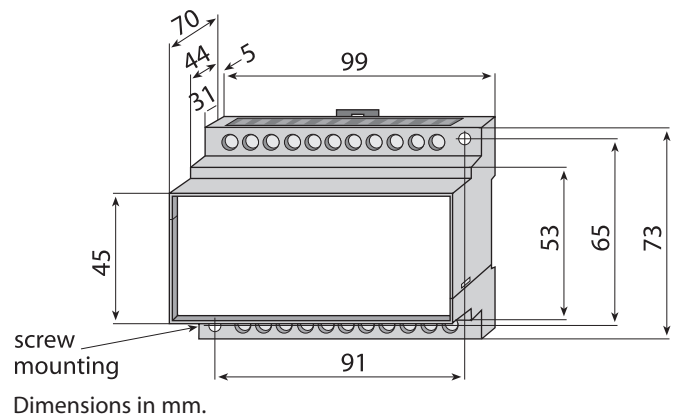

4.1

Dimension diagram, enclosure measuring current transformer W1000

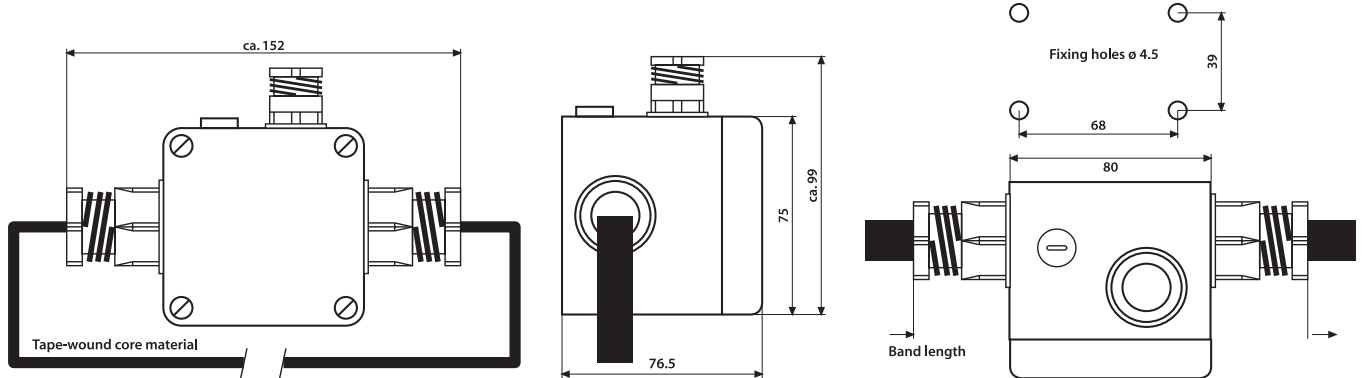

Flexible CTs	W500	W600	W700	W800	W900	W1000
Length (mm)	500	600	700	800	900	1000

Lengths of the tape-wound core