

Signal converter SMI472-12



Signal converter SMI472-12

Product description

The signal converter SMI472-12 converts digital signals (operating and alarm messages) to serial output signals for the BMS bus. Its 12 digital inputs can be split into two groups as alarm or operating messages. Factory setting: 8 inputs for alarm messages and 4 inputs for operating messages.

Function

One LED indicator is assigned to each of the inputs IN1 to IN12. The operating principle of the inputs can be set to N/O or N/C operation via a DIP switch. One common alarm relay in N/O operation is available for the transfer of alarm messages.

The SMI472-12 converts the input signals to serial output signals for the BMS bus. Via this interface messages can be transferred to other Bender devices (e.g. to alarm indicator and test combinations of the MK2430 / MK800 series or to TM operator panels).

Note: A BMS bus master is required to operate the SMI472-12.

Device features

- 12 digital inputs
- Indicator LED for each channel
- LEDs: Power On, ALARM, activities on the RS-485 interface
- RS-485 interface (BMS bus)
- Operating principle selectable: N/O or N/C operation.

Operating elements

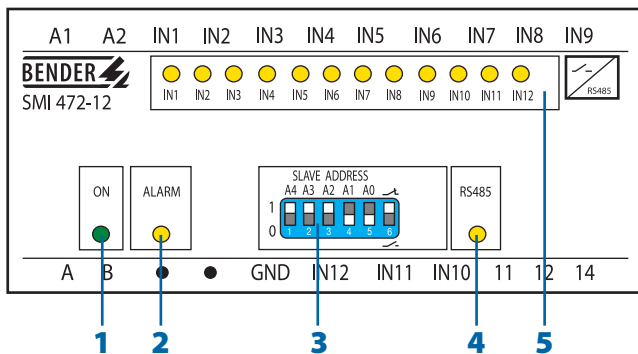

- 1 - LED "ON": operation indicator
- 2 - LED "ALARM": lights whilst an alarm is present at one of the alarm inputs and flashes in case of an impermissible address.
- 3 - DIP switches to set the device address and the operating mode of the digital inputs
- 4 - LED "RS-485": lights in case of activities on the BMS bus
- 5 - LED "IN1...IN12": LED lights whilst an alarm or operating-message is present on the respective input.

Ordering information

Type	Supply voltage U_S	Art. No.
SMI472-12	DC 77...286 V/AC 85...265 V 50...60 Hz	B 9204 7011
SMI472-1221	DC 10.5...80 V	B 9204 7013

Dimension diagram X470

Dimensions are given in mm

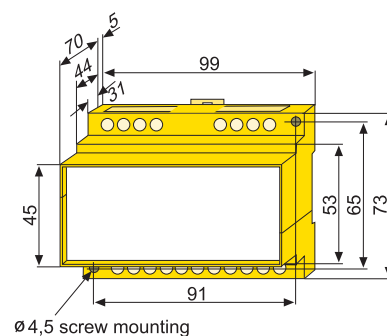

Wiring diagram

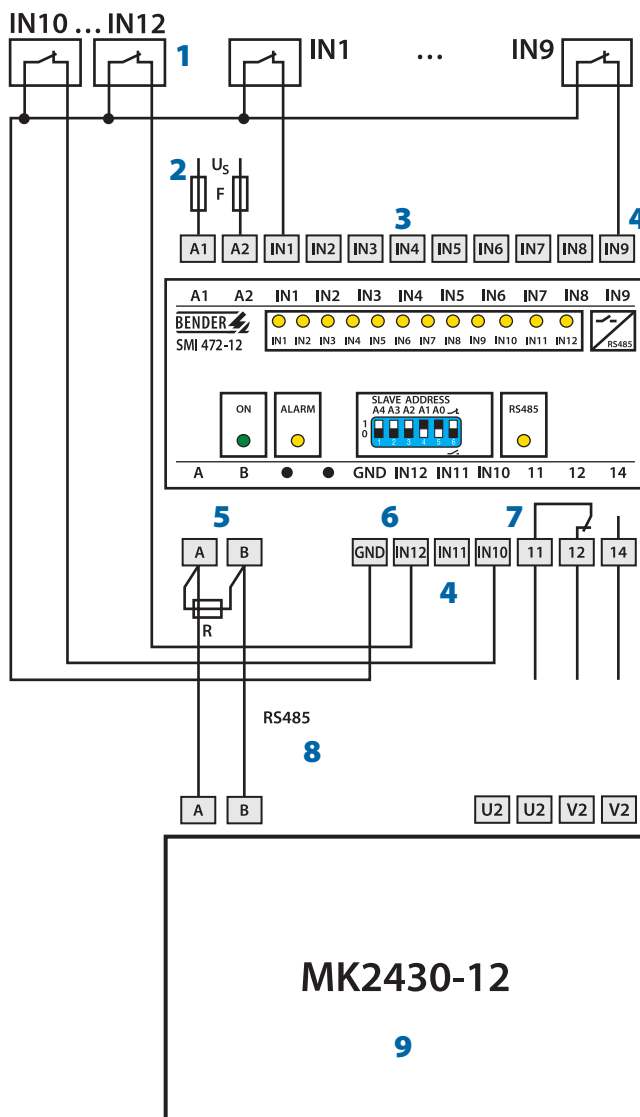

- 1 - Potential-free relay contacts
- 2 - Connection of the supply voltage U_s , short-circuit protection for supply voltage U_s , 6 A recommended
- 3 - IN1...IN8 digital inputs for alarm messages
- 4 - IN9...IN12 digital inputs for operating messages
- 5 - Connection BMS bus
- 6 - Common connection of the digital inputs to earth
- 7 - Alarm relay with the contacts 11, 12 and 14 (common alarm for alarm messages on IN1...IN8)
- 8 - Terminating resistor BMS bus
- 9 - MK2430-12 alarm and test combination, alarm texts can be set as required

Technical data signal converter SMI472-12

Insulation coordination acc. to IEC 60664-1	
Rated insulation voltage	AC 250 V
Rated impulse voltage/pollution degree	4 kV/3
Supply voltage	
Supply voltage U_s	see ordering information
Frequency range U_s	50...60 Hz
Operating range U_s	0.8...1.15 x U_s
Power consumption	≤ 12 VA
Inputs	
Digital inputs	12 (IN1...IN12) (parameter setting: alarm/operating messages)
Operating principle selectable via DIP switch	N/C operation / N/O operation selectable
Factory setting	N/O operation
Galvanic separation	no
Activation of digital inputs	via potential-free contacts
Displays	
LEDs	15 (ON, Alarm, RS-485, IN1...IN12)
Interface	
Interface/protocol	RS-485/BMS
Baud rate	9.6 kbit / s
Cable length	≤ 1200 m
Recommended cable (shielded, shield connected to PE on one side)	min. J-Y(St)Y 2 x 0.6
Terminating resistor (connectable via DIP switch)	120 Ω (0.25 W)
Device address, BMS bus	DIP switch 2...30
Factory setting, device address	3
Switching elements	
Number of changeover contacts	1 changeover contact
Operating principle parameter setting via BMS bus	N/O operation
Contact data acc. to IEC 60947-5-1	
Rated operational voltage U_e	AC 230 V / DC 220 V
Rated operational current I_e	AC 5 A / DC 0.2 A
Utilization category	AC 14/DC 12
Electrical service life, number of cycles	10.000
Minimum contact load	1 mA at AC / DC > 10 V
General data	
EMC immunity	acc. to EN 61000-6-2
EMC emission	acc. to EN 61000-6-4
Classification of climatic conditions acc. to IEC 60721	
Stationary use /transport/storage	3K5/2K3/1K4
Operating temperature	- 10 °C... + 55 °C
Classification of mechanical conditions acc. to IEC 60721	
Stationary use/transport/storage	3M4/2M2/1M3
Operating mode	continuous operation
Mounting	any position
Connection	screw-type terminals
Connection properties	
rigid/flexible/conductor sizes	0.2...4/0.2...2.5 mm ² /AWG 22-12
flexible with ferrule, without/with plastic sleeve	0.25...2 mm ²
Stripping length	8 mm
Tightening torque	0.5 Nm
Degree of protection, internal components /terminal (DIN EN 60529)	IP 30 / IP 20
Type of enclosure/dimension diagram	X470
Screw mounting	2 x M4
DIN rail mounting acc. to	IEC 60715
Flammability class	UL94V-0
Operating manual	BP204010
Weight	≤ 320 g