

Signal converter SMO481-12



Signal converter SMO481-12

Product description

The signal converter SMO481-12 converts BMS bus switching commands to relay contact messages. The relay contacts are also suitable for very low currents (> 5 mA).

Application

- To convert BMS switching commands from TM operator panels to relay messages, e.g. for lighting system or device control

Function

When the signal converter SMO481-12 receives a switching command via the BMS bus, this command will be converted to a relay message.

Device features

- 12 relay outputs
- Operating mode selectable: N/O or N/C operation.
- LED for each channel
- Test button to check the relay function
- LEDs: Power On, ALARM, TEST/FAULT

Operating elements

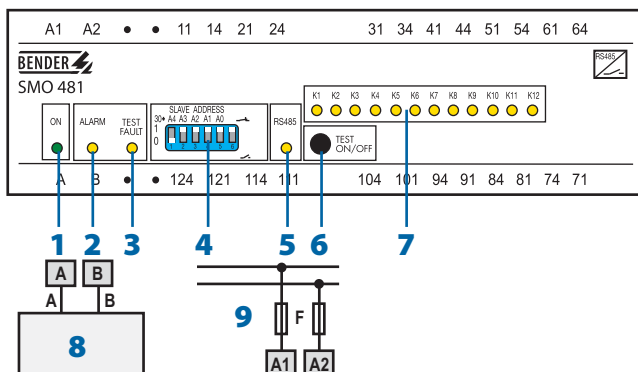

- 1 - LED "ON": operation indicator
- 2 - LED "ALARM": lights whilst one (or several) relays respond and during the test mode.
- 3 - LED "TEST/FAULT": LED lights during the test mode and flashes when an impermissible address has been selected.
- 4 - DIP switch, to set the device address of SMO481-12 (address = parameter value + 30) and the operating mode of the alarm relay.
- 5 - LED "RS-485": lights in case of activities on the BMS bus
- 6 - "TEST ON/OFF" button: pressing the test button once: will change over the operating mode of all alarm relays, pressing the test button once again: will change over from the test mode to the normal operating condition.
- 7 - LED "K1...K12": LED lights whilst respective relay responds
- 8 - Connection to TM operator panel
- 9 - U_S see ordering information, short-circuit protection for supply voltage U_S , 6 A fuse recommended, Note: Supply voltage U_S in the IT system requires two fuses

Ordering information

Type	Supply voltage U_S	Art. No.
SMO481-12	AC 230 V	B 9204 7005

Dimension diagram X480

Dimensions are given in mm

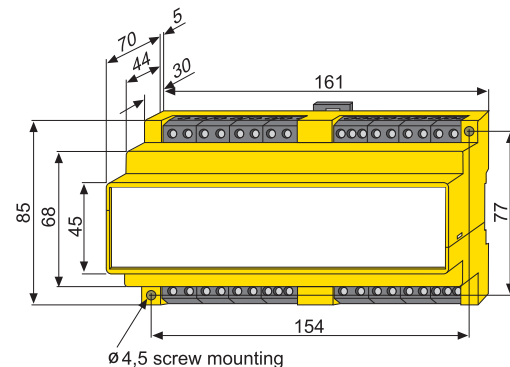

Wiring diagram

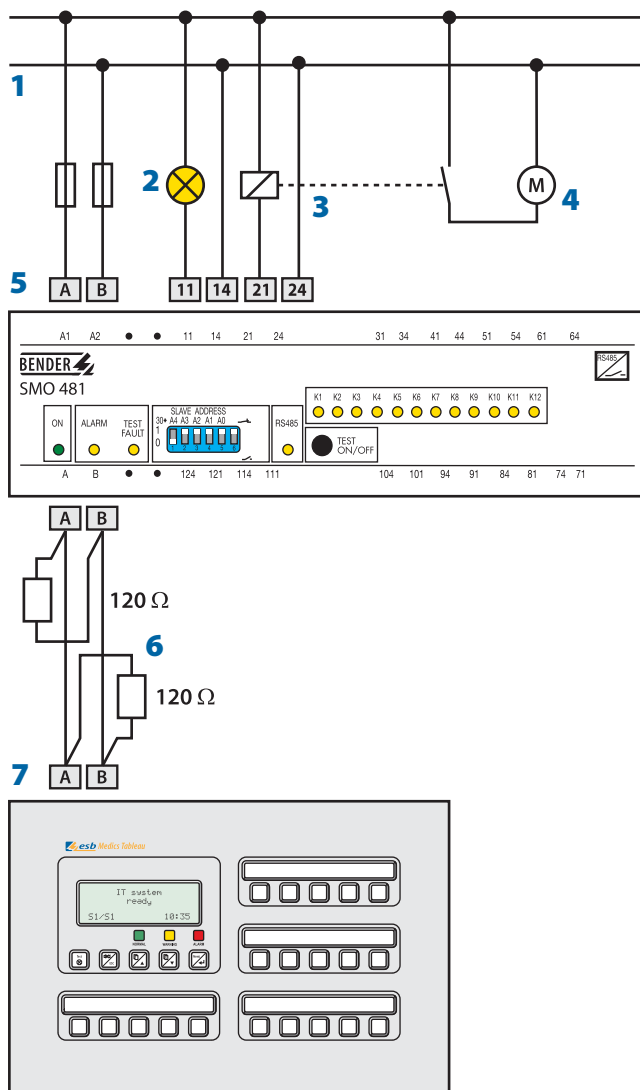

- 1 - U_S see ordering information
- 2 - Load (direct control)
- 3 - Relay to control load 4
- 4 - Load
- 5 - Signal converter SMO481-12
- 6 - Terminating resistors BMS bus
- 7 - TM operator panel

Technical data signal converter SMO481-12

Insulation coordination acc. to IEC 60664-1	
Rated insulation voltage	AC 250 V
Rated impulse voltage/pollution degree	4 kV/3
Supply voltage	
Supply voltage U _S	AC 230 V
Frequency range U _S	50...60 Hz
Operating range U _S	0.8...1.15 x U _S
Power consumption	≤ 8 VA
Displays	
LEDs	16 (ON, Alarm, TEST/FAULT, RS-485, K1...K12)
Operating elements	
Button	TEST ON/OFF
Interface	
Interface/protocol	RS-485/BMS
Baud rate	9.6 kbit / s
Cable length	≤ 1200 m
Recommended cable (shielded, shield connected to PE on one side)	min. J-Y(St)Y 2 x 0.6
Terminating resistor (connectable via DIP switch)	120 Ω (0.25 W)
Device address, BMS bus	30 + (1...30)
Factory setting device address	30 + 1;
Switching elements	
Number	12 x 1 N/O contacts
Operating principle	N/C operation / N/O operation selectable
Factory setting	N/O operation
Contact data acc. to IEC 60947-5-1	
Rated operational voltage U _e	AC 230 V / DC 220 V
Rated operational current I _e	AC 5 A / DC 0.2 A
Utilization category	AC 14/DC 12
Electrical service life, number of cycles	10.000
Minimum contact load	1 mA at AC / DC > 10 V
General data	
EMC immunity	acc. to EN 61000-6-2
EMC emission	acc. to EN 61000-6-4
Classification of climatic conditions acc. to IEC 60721	
Stationary use /transport/storage	3K5/2K3/1K4
Operating temperature	- 25 °C...+ 55 °C
Classification of mechanical conditions acc. to IEC 60721	
Stationary use/transport/storage	3M4/2M2/1M3
Operating mode	continuous operation
Mounting	any position
Connection	13 x 1 N/O contacts
Connection properties	
rigid/flexible/conductor sizes	0.2...4/0.2...2.5 mm ² /AWG 22-12
flexible with ferrule, without/with plastic sleeve	0.25...2 mm ²
Stripping length	8 mm
Tightening torque	0.5 Nm
Degree of protection, internal components (IEC 60529)	IP 30
Degree of protection, terminals (IEC 60529)	IP 20
Type of enclosure/dimension diagram	X470
Screw mounting	2 x M4
DIN rail mounting acc. to	IEC 60715
Flammability class	UL94V-0
Product standards	EN 50178 for AC 230 V
Operating manual	BP108011
Weight	≤ 580 g