



Brüel & Kjær Vibro



VIBROPORT 80 VP-80 / VP-80 E

**Vibration analysis
Rotor balancing
Machine maintenance**

Brüel & Kjær Vibro GmbH - Leydhecker Str. 10 - 64293 Darmstadt

Translation of the Original Operating Instructions

VP-80

VP-80 E





Company details

Contact

Brüel & Kjær Vibro GmbH
Leydhecker Str. 10
64293 Darmstadt

Service Hotline

Tel.: +49(0)6151 / 428 1400
Fax: +49(0)6151 / 428 1401
E-Mail: info@bkvibro.com
Internet: www.bkvibro.com

Exclusion of liability

We have compiled our technical documentation very carefully. All information has been provided in accordance with the state-of-the-art and to the best of our knowledge and belief. However, we cannot accept liability for the accuracy and completeness of the information provided, except in the case of gross negligence. In particular, the information does not have the legal quality of assurances or assured properties.

The latest version of the documentation is always available on the Internet. Due to technical developments these documents may differ from the version provided with a product at delivery. For this reason please always use the documentation provided with the product for installation and operation. Information on inaccuracies in this documentation will be gratefully received. We reserve the right to make technical modifications.

All rights reserved

No part of this publication may be reproduced, stored in a retrieval system or transmitted, in any form, or by any means, electronic, mechanical, photocopying, recording or otherwise without prior written permission from Brüel & Kjær Vibro GmbH.

The right to make changes at any time without notice is reserved.

Copyright 2012, Brüel & Kjær Vibro GmbH, D-64293 Darmstadt
10/2012 - C104674.002 - Version 02



(D) Achtung !

Vor Inbetriebnahme des Produktes muss die Betriebsanleitung gelesen und verstanden werden.

Bei Bedarf die Betriebsanleitung in fehlender EU-Sprache unter folgender Adresse anfordern:

www.bkvibro.com

(E) Nota importante!

Antes de utilizar este producto debe leer y comprender el manual.

Si necesita el manual en otro idioma de la Unión Europea, puede pedirlo en la siguiente dirección:

www.bkvibro.com

(NL) Attentie!

Voor ingebruikname van het produkt dient de gebruiksaanwijzing gelezen en begrepen te zijn.

Bij behoefte aan een gebruiksaanwijzing in een ontbrekende EU-taal is deze op onderstaand adres aan te vragen:

www.bkvibro.com

(SF) Huomio!

Ennen käyttöönottoa tulee lukea ja ymmärtää käyttöohjeet.

Kun tarvitset käyttöohjeita muilla EU-kielillä ota yhteys seuraavaan osoitteeseen:

www.bkvibro.com

(PL) Uwaga!

Przed rozpoczęciem użytkowania urządzenia uprzejmie prosimy o uważne zapoznanie się z instrukcją obsługi.

Instrukcje obsługi dla naszych urządzeń dostępne są we wszystkich oficjalnych językach Unii Europejskiej. Brakujące egzemplarze można zamawiać pod wskazanym poniżej adresem:

www.bkvibro.com

(GB) Note!

Before operating the product the manual must be read and understood.

If necessary you may order the manual in the missing European Union language under the following address:

www.bkvibro.com

(I) Nota !

Il manuale deve essere letto e compreso prima della messa in servizio del prodotto.

Se necessario, il manuale mancante nella lingua Europea desiderata, è ordinabile al seguente indirizzo:

www.bkvibro.com

(DK) Henvising:

Før produktets ibrugtagning skal brugsanvisningen læses og forstås!

Brugsanvisningen kan bestilles på et EU-sprog ved henvendelse til:

www.bkvibro.com

(GR) Προσοχή !

Προτού λειτουργήσετε την συσκευή, πρέπει να διαβάσετε και να καταλάβετε το εγχειρίδιο.

Εάν χρειάζεσθε εγχειρίδιο σε κάποια άλλη Ευρωπαϊκή γλώσσα, αποστανθείται στην εξής διεύθυνση :

www.bkvibro.com

(CZ) Pozor!

Před uvedením výrobku do provozu je nutné přečíst si návod k provozu a porozumět mu.

V případě potřeby si návod k provozu v chybějící řeči EU vyžádejte na následující adrese:

www.bkvibro.com

(F) ATTENTION !

Avant utilisation de l'appareil, il faut impérativement avoir lu et compris le manuel d'emploi.

Si besoin, commander le manuel d'emploi dans la langue manquante à l'adresse suivante :

www.bkvibro.com

(P) Atenção !

Antes de usar o produto é necessário ler a documentação e entender-la.

Se for necessário é favor pedir a documentação na língua europeia que necessita dirigindo-se a está direção:

www.bkvibro.com

(S) Observera !

Före idrifttagning av produkten måste bruksanvisningen läsas och förstås.

Om nödvändigt kan bruksanvisningen beställas i det saknade EU-språket under följande adress:

www.bkvibro.com

(H) Figyelem!

A termék üzembe helyezése előtt az üzemeltetési utasítást el kell olvasni, és meg kell érteni.

Szükség esetén hiányzó EU-nyelven az üzemeltetési utasítást, az alábbi címen lehet igényelni:

www.bkvibro.com

(SK) Upozornenie !

Pred uvedením zariadenia do prevádzky si treba dôkladne prečítať prevádzkový návod a treba jeho obsah správne pochopiť.

V prípade potreby si prevádzkový návod vyžiadajte v príslušnom jazyku EÚ na nasledovnej adrese:

www.bkvibro.com



(SLO) Pozor!

Pred zagonom proizvoda morate najprej prebrati in razumeti navodilo za uporabo.

Po potrebi zahtevajte navodilo za uporabo v jeziku EU, ki vam manjka, na naslednjem naslovu:

www.bkvibro.com

(LV) Uzmanību!

Pirms produkta ekspluatācijas uzsākšanas, rūpīgi izlasiet lietošanas instrukciju.

Vajadzības gadījumā pieprasiet lietošanas instrukciju izstūkstošajā ES valodā pa šādu adresi:

www.bkvibro.com

(LT) Dėmesio!

Prieš pradėdant naudoti produktą, atidėziai perskaitykite instrukciją.

Esant reikalui, reikalaukite instrukcijos trūkstama ES kalba tokiu adresu:

www.bkvibro.com

(EST) Tähelepanu!

Enne toote kasutuselevõttu tuleb kasutusjuhend läbi lugeda ja sellest aru saada.

Kui vajate kasutusjuhendit mõnes muus EL keeles, küsige seda järgmiselt aadressilt:

www.bkvibro.com

(M) Note!

Before operating the product the manual must be read and understood.

If necessary you may order the manual in the missing European Union language under the following address:

www.bkvibro.com

(BG) Внимание!

Преди въвеждане в експлоатация на продукта ръководството му трябва да бъде прочетено и разбрано.

При нужда от ръководство на липсващ EU език, Вие можете да го поръчате на следния адрес:

www.bkvibro.com

(RO) ATENTIE !

Inainte de utilizarea produsului trebuie sa cititi si sa ințelegeți prezentul manual de operare.

La nevoie puteți comanda manualul de operare într-una din limbile recunoscute oficial în U.E. la următoarea adresa:

www.bkvibro.com



1	Basic Information.....	1-1
1.1	Technical specifications	1-1
1.2	Intended use	1-2
1.3	Obvious misuse	1-2
1.4	Explanation of symbols and terminology	1-3
2	Safety Advice.....	1-5
2.1	General safety advice	1-5
2.2	Handling vibration measuring and monitoring instruments	1-7
2.3	Qualification of the operating authority	1-7
2.4	Maintenance and repair	1-7
2.5	Unauthorized modifications	1-8
2.6	Electromagnetic compatibility (EMC)	1-8
2.7	Low Voltage Directive	1-9
2.8	IP protection	1-9
3	Safety in Potentially Explosive Atmospheres	1-10
3.1	ATEX certificate and markings	1-10
3.2	General information	1-11
3.3	Safety advice	1-12
4	Scope of Supply (Basic Unit).....	1-16
5	Technical Data.....	1-18
6	Basic Operation.....	1-25
6.1	Overview of hardware for the VIBROPORT 80	1-25
6.1.1	Front	1-25
6.1.2	Connection plate	1-30
6.1.3	Power supply module	1-35
6.1.4	Battery	1-37
6.1.5	Docking station	1-41
6.1.6	Folding out the bracket	1-42
6.1.7	SD storage card slot	1-43
6.1.8	Inserting the SD storage card	1-44
6.2	Connecting the VIBROPORT 80 to the PC	1-45
6.2.1	Connecting via the USB interface	1-45
6.2.2	Synchronization software	1-46
6.2.3	Report & EXaminer Software	1-47
6.3	Reset function	1-52
6.3.1	Performing a warm start	1-52
6.3.2	Performing a cold start	1-52



7	Operator Interface	1-54
7.1	Explanation of symbols	1-54
7.2	Structure of the operator interface	1-55
7.3	Main mask	1-57
7.4	Licensing	1-58
7.5	Module overview	1-59
7.6	Softkeys	1-65
7.6.1	General	1-65
7.6.2	Generally valid softkeys	1-66
7.6.3	Level 1 / Main mask	1-66
7.6.4	Level 2 / Modules	1-69
7.6.5	Level 3 / Measurement setup and report mask	1-71
7.6.6	Level 4 / Measurements mask	1-73
7.7	Measuring data analysis - zoom and cursor keys	1-76
7.8	Setup settings	1-78
7.8.1	System Setup	1-78
7.8.2	Sensor Setup	1-83
8	Example measurement - Overalls	1-86
8.1	Start of example measurement	1-89
8.2	Perform new measurement	1-89
8.3	Perform predefined measurement	1-90
8.4	Perform last measurement and check setup	1-91
8.5	Directly start last measurement	1-92
8.6	Change display / representation during measurement	1-93
8.7	End current measurement	1-94
8.8	Save measurement	1-95
8.9	Load and execute saved measurement (open report)	1-97
9	Setup Parameters for the Measuring Modules	1-98
9.1	General	1-98
9.2	Important notes on the modules	1-98
9.2.1	Vibration acceleration and vibration displacement measurements	1-98
9.2.2	FFT-Analyzer module	1-99
9.2.3	Balancer module	1-99
9.2.4	Time Signal module	1-100
9.2.5	Tracking	1-100
9.3	Overalls	1-101
9.4	FFT-Analyzer	1-104
9.5	Balancer	1-107



9.6	Tracking	1-110
9.6.1	Tracking - signal processing setup	1-113
9.7	Transfer Function	1-114
9.8	Time Signal	1-118
10	Recycling / Disposal	1-120
11	CE Declaration of Conformity	1-121
12	Supplier´s Declaration of Conformity	1-122



1 Basic Information

1.1 Technical specifications

The VIBROPORT 80 / VIBROPORT 80 *E* is a portable and flexible vibration measuring and balancing instrument.

The VIBROPORT 80 can be used for a multitude of measuring tasks and supports up to four input channels for vibration, to which all standard types of vibration sensors can be connected. It is thus ideally suited for early fault detection and diagnosis of imminent faults in bearings, shafts, transmissions, couplings and housings of auxiliary units, as well as production-critical machines.

Properties:

- Modular design
- For first time users and experienced diagnosticians
- ATEX/IECEX version for potentially explosive atmosphere (only VP-80 E)
- Pre-defined measuring tasks and setups for quick and efficient measurement and analysis
- Extensive vibration analysis (overalls, FFT spectra, rolling-element bearing fault diagnosis and more). The following chapters contain further information
- Balancing (two-plane field balancing with polar plots)
- Saving of time signals in wave file format (*.wav)

Features:

- Large color display
- Ergonomic keyboard
- Robust housing
- High-quality box with accessories and sensors (standard scope of supply)
- Report & EXaminer software for further data processing, analysis and reports on the PC



Further high-performance modules:

- Retrofittable at any time, also for demanding measuring tasks and applications (e.g. Tracking or Transfer Function).

The VP-80 can be extended with further sensors, additional modules and accessories to adapt it to your individual requirements. Further information can be found in the brochures and sales documentation on our website www.bkvibro.com.

The following terms are used as standard in this manual:

VP-80 instead of VIBROPORT 80.

VP-80 E instead of VIBROPORT 80 E for the explosion-proof version.

1.2 Intended use

The VIBROPORT 80 is a portable data acquisition and storage device with up to four input channels for vibration (AC, dynamic) and/or process values (DC, quasi static) as well as an additional input channel for reference signals (phase/speed).

In conjunction with visual checks, the VIBROPORT 80 enables detailed analysis of machine states even in extreme industrial environments. The relevant data are logged, displayed and stored.

1.3 Obvious misuse

The VIBROPORT 80 is not intended for use as a stationary monitoring unit for machines nor for providing alerts in respect of machine states. No relays / signal outputs are provided for this purpose, as with other products from Brüel & Kjær Vibro GmbH.



Note!





Brüel & Kjær Vibro GmbH cannot accept liability for damages resulting from improper use. The risk is borne solely by the user.



1.4 Explanation of symbols and terminology

Explanation of symbols

Our products are manufactured according to state-of-the-art technology and in compliance with the acknowledged safety regulations. However, residual dangers do still exist, and reference is made to these in the documentation in the form of pictograms.

Picto-gram	Explanation
	Caution This pictogram and signal word warns against hazards which can cause physical injuries.
	Warning This pictogram and signal word warns against hazards which can cause death or severe injuries.
	Electricity This pictogram and signal word warns against electrical hazard areas.
	Explosive atmosphere This pictogram and signal word warns against hazards in explosive atmospheres.

Tab. 1 Explanation of symbols and terminology



Note!

This pictogram and signal word indicates sections in the manual which provide useful information on handling the VIBROPORT 80.

It also refers to critical situations which can result in damage to the VIBROPORT 80 or malfunctions and false measuring results.

Instructions

The following symbols are used to help you when carrying out actions:

- This is an action step / instruction directed at you.
- ⇒ This concerns results of actions.

Function keys and softkeys

The function keys and softkeys explained below are written in capitals so that they can be instantly distinguished from the text, for example:

OK, AVERAGE, START and EXIT.

Commands, modules, masks and input keys (fire keys)

The commands, modules, masks and input keys (fire keys) are written in italics so that they can be instantly distinguished from the text, for example:

Save, Overalls, Main mask, System setup, Sensor setup and input key (fire key).



2 Safety Advice

2.1 General safety advice

This chapter provides an overview of all relevant general safety advice for the VIBROPORT 80.



Note!

When handling the VIBROPORT 80 and its accessories, the live components constitute a potential hazard source. Voltages of over 50 V do not occur in the VIBROPORT 80 but only in the power supply module, and are generally categorized as hazardous.



Note!

The enclosed operating instructions for the AC-7001 power supply module must be read, understood and complied with. Pay special attention to the operating temperature of the power supply module.



WARNING!

Explosive atmosphere!

This power supply module can cause explosions in potentially explosive atmospheres, resulting in damage to property and injuries.

- Never use the power supply module in potentially explosive atmospheres.
-



WARNING!

Electricity!

The AC-7001 power supply module has a 230 V voltage.

Contact with non-insulated areas will result in personal injuries, as well as damage to the VIBROPORT 80.

- Avoid contact with live parts.
-



WARNING!

Electricity!

Live components in the VIBROPORT 80 are hazardous areas. These include: various soldered points, printed conductors, mains connection terminals, relay contacts, etc..

Contact with these areas will result in personal injuries, as well as damage to the VIBROPORT 80.

- Do not open the device.
- Switch off the mains voltage before opening the battery compartment or the SD storage card slot.
- Avoid coming into contact with live components.



Note!

Only expose the VIBROPORT 80 to permissible ambient influences (temperature, air humidity, vibrations).

Non-observance can cause faults and damage to the VIBROPORT 80.



Note!

Only use genuine spare parts in the VIBROPORT 80.



Note!

The VIBROPORT 80 is not designed for long-term use under UV light.



Note!

Before commissioning, test the local mains voltage check and compare it with the voltage range of the AC-7001 power supply module. The AC-7001 Operating Instructions are included in the scope of supply. If the mains voltage is different, this can cause damage to the power supply module and/or to the VIBROPORT 80.



Note!

The battery connections must not be short-circuited! This will cause damage to the battery / the VIBROPORT 80.

2.2 Handling vibration measuring and monitoring instruments

The following safety advice must be adhered to when handling our products, in order to protect against risk of injury.

For your own safety you must have read and understood the pertinent safety advice before working with the VIBROPORT 80.

Keep the safety advice in a safe place, where it can be accessed by all persons who work with the VIBROPORT 80.

2.3 Qualification of the operating authority

Inadequate qualification can result in incorrect settings being made on the VIBROPORT 80, which can have far-reaching consequences, e.g. machine damage, personal injuries.

Only competent, expert and authorized personnel are permitted to carry out work in connection with our products.

2.4 Maintenance and repair

Repairs may only be carried out by trained personnel from the company's headquarters or an authorized Brüel & Kjær Vibro GmbH service station. Only simple activities such as changing batteries, cleaning, testing connections, etc. can be performed by the user.



Note!

Use a slightly damp cloth for cleaning.



Note!

The seals of the battery compartment, the SD storage card slot and the housing of the VIBROPORT 80 must be regularly checked to ensure the integrity of the water and dust protection.



Note!

The electrical equipment must be regularly maintained. Defects such as loose connections, defective plug connectors, etc. must be remedied by Brüel & Kjær Vibro GmbH immediately.

2.5 Unauthorized modifications

Modifications to the design or safety features of the device and its accessories require our express consent. We shall not be liable for any damages resulting from modifications made without our express consent.

In particular all repairs, soldering of boards and the replacement of components and printed circuit boards are forbidden without the express authorization of Brüel & Kjær Vibro GmbH.

2.6 Electromagnetic compatibility (EMC)

The VIBROPORT 80 fulfils the relevant requirements of directive 2004 / 108 / EC on electromagnetic compatibility.

The EMC has been tested in accordance with EN 61326:2006, with reduction of the requirement for static electricity (ESD) from 4kV to 2kV (EN 61000-4-2).

The VIBROPORT 80 fulfils Class A (industrial sector) for emitted interference in accordance with EN55011.



Note!

Avoid electrostatic discharges in the area of sockets / connections (input channels).

Excessive electrostatic discharges at the sockets can cause a running measurement to suddenly stop (the values freeze on the display).

The measurement can be continued after restarting the VIBROPORT 80.



Note!

Electromagnetic interference can influence the measured values and should be avoided as far as possible.

2.7 Low Voltage Directive

The VIBROPORT 80 fulfils the relevant requirements of Low Voltage Directive 2006 / 95 / EC in accordance with EN 61010:2010.

2.8 IP protection



Note!

Protect unused sockets with the AC-7301 protective caps provided. These will protect the sockets of the VIBROPORT 80 from water or dust.



Note!

Insert the seal and the cover of the SD storage card slot (AC-7310 / VP-80 E or AC-7311 / VP-80) correctly. This will protect the SD storage card slot from water, dust and other external influences.



3 Safety in Potentially Explosive Atmospheres

3.1 ATEX certificate and markings

Explosion protection

according to 94/9/EC, only for *VP-80 E*.

EC-type examination certificate

TRAC10ATEX31265X

Marking



ATEX II 3G Ex ic IIC T4 Gc Ta= -10°C to +50°C

Compliance with standards

EN 60079-0:2009

EN 60079-11:2007

Further explosion-protection approvals for *VP-80 E*

IECEX TRC 10.0011

Maximum values

- **Channel CH1 & CH2**

$$U_0 = 25 \text{ V}$$

$$I_0 = 2.9 \text{ mA}$$

$$P_0 = 100 \text{ mW}$$

$$C_i = 0$$

$$L_i = 0$$

- **Channel USB DEV / TRIG / PWR**

$$U_0 = 5.5 \text{ V}$$

$$I_0 = 75 \text{ mA}$$

$$P_0 = 275 \text{ mW}$$



$C_i = 300 \text{ nF}$

$L_i = 0$

Marking

II 3G Ex ic IIC T4 Gc Ta= -10°C to +50°C

CSA approval only for VP-80

CSA Class I, Div 2 Groups A, B, C & D, Temperature Code
T4A@Ta=50C

3.2 General information

In the following you will find safety advice in relation to the use of the VIBROPORT 80 *E* in potentially explosive atmospheres.

This information is based on Directive ATEX 94/9/EC.



Note!

In addition to the general installation regulations for electrical systems, when installing electrical systems in potentially explosive atmospheres IEC 60079-14 and the relevant national requirements on the installation of explosion-proof systems must be observed.



3.3 Safety advice



WARNING!

Explosive atmosphere!

Do not use channel CH R in a potentially explosive atmosphere.

This can result in explosions, personal injuries and damage to the VIBROPORT 80 due to sparking.

- Do not use channel CH R for measuring in these areas.
 - The input socket must be covered with the protective cap provided.
 - Pins EXT TRIG AUX and +5V-EXT of channel USB DEV / TRIG / PWR can be used for connecting to the explosion-proof VIBROPORT 80 E.
 - Only sensor PA-98 provided for this purpose can be connected to channel USB DEV / TRIG / PWR.
 - Sensors and cables may only be connected outside the Ex zone.
-



WARNING!

Explosive atmosphere!

All unused connections (input sockets) must be covered with protective caps when using the VIBROPORT 80 E in a potentially explosive atmosphere. Connections without protective caps can cause explosions, resulting in damage to property and injuries.

- Cover all unused connections on the VIBROPORT 80 with the AC-7301 protective caps.
 - The AC-7301 protective caps may only be fitted and removed outside the Ex zone.
-



WARNING!



Explosive atmosphere!

The VIBROPORT 80 E has been exclusively designed for connection to a defined group of sensors approved for explosive atmospheres.

The use of other, non-approved sensors in explosive atmospheres can cause explosions, resulting in damage to property and injuries.

- Therefore only use the approved sensors in explosive atmospheres: We recommend the sensors manufactured by Brüel & Kjær Vibro GmbH, as specified in the table below.

Manufacturer	Model	Certificate
Brüel & Kjær Vibro GmbH	8326x xx x xxxx	DEMKO 01 ATEX 128807X
Brüel & Kjær Vibro GmbH	ASA-06x	PTB 07 ATEX 2008

Tab. 2 Overview of sensors defined by ATEX / IECEx

WARNING!



Explosive atmosphere!

Do not charge the battery of the VIBROPORT 80 E in potentially explosive atmospheres. The power supply module and docking station must not be operated in Ex zones.

This can cause explosions, resulting in damage to property and injuries.

- Therefore only charge the battery outside potentially explosive atmospheres.
- Never use the power supply module and docking station in potentially explosive atmospheres.



WARNING!

Explosive atmosphere!

Do not change the battery and the power supply module of the device in potentially explosive atmospheres.

This can cause explosions, resulting in damage to property and injuries.

- Therefore only change the battery outside potentially explosive atmospheres.
- Only use the power supply module outside potentially explosive atmospheres.



WARNING!

Explosive atmosphere!

Do not use the docking station and power supply module in potentially explosive atmospheres.

This can cause explosions, resulting in damage to property and injuries.

- Only use the docking station and power supply module outside Ex zones.



WARNING!

Explosive atmosphere!

The AC-7310 cover (for SD storage card slot and charging pins) may only be opened outside potentially explosive atmospheres.

Do not insert or replace the SD storage card in an explosive atmosphere.

This can cause explosions, resulting in damage to property and injuries.

- Do not open the cover in potentially explosive atmospheres.
 - Only insert and replace the SD storage card in non-hazardous atmospheres.
-



WARNING!

Explosive atmosphere!

The housing must be opened when performing a cold start (see “Performing a cold start” on page 46).

This can cause explosions, resulting in damage to property and injuries.

- Do not carry out a cold start in a potentially explosive atmosphere.



4 Scope of Supply (Basic Unit)

VIBROPORT 80 – Analyzer Select comprising:

- One VIBROPORT 80 measuring instrument with standard accessories
- Delivered in AC-7101 shipping case
- One Report & EXaminer software Standard/Client license and CMC USB driver on CD (with USB dongle)
- Rechargeable battery / storage battery BP-15 (AC-7003), already installed
- SDHC storage card 4 GB (enclosed)
- Docking station AC-7307
- Power supply module AC-7001 (including operating instructions)
- USB connection cable (PC) AC-1390
- Y-cable USB-Power AC-1389
- Shoulder strap AC-7309
- Protective cover AC-7305
- Hand straps (2x) AC-7308
- Leather bag for small components AC-7306
- Protective caps for input sockets AC-7301
- One vibration acceleration sensor AS-063 (with threaded bolt AC-350)
- One magnet AC-273
- One probe tip AC-272
- One sensor connection cable AC-1384/0050 (5m, smooth)
- Basic overalls: Module 1.1
- FFT-Analyzer: Module 2.1 and 2.2 (envelope spectrum BCS/SED)
- 2-channel function: Module 4
- Technical documentation



**VIBROPORT 80 – Balancer Select (like Analyzer Select)
and additional equipment comprising:**

- Second vibration acceleration sensor AS-063 (with threaded bolt AC-350)
- Second magnet AC-273
- Second sensor connection cable AC-1384/0050 (5m, smooth)
- Option 806 (reference sensor P-98 with accessories)
- Balancing: Module 7

VIBROPORT 80 E



Note!

The hardware of the VIBROPORT 80 *E* only differs very slightly from that of the VP-80. In particular, the BP-15-CC (AC-7004) battery and the housing are designed for potentially explosive atmospheres, as are the relevant sensors PA-98 and ASA-063.



5 Technical Data

In the following we have provided an overview of the most important technical data of the VIBROPORT 80, divided into categories.



Note!

You can download a detailed description of the technical data as a PDF document from our website www.bkvibro.com.

Units

- Acceleration (g, m/s², BCUp, ECUp)
- Velocity (mm/s, in/s)
- Displacement (mm, mils)
- Volt/mV
- Single or double integration (double)
- Units interchangeable (metric/imperial)

Speed / process values.



Note!

Volts are always used as input value on principle. The readable values are not directly measured, but are recalculated internally. The sensor sensitivity (e.g.: mV[°C]) must always be taken into account during measurement.

- rpm, Hz
- Nm, A, kW, m³/s, MP, bar, °C, F, N, μm, mm, mil, in, V (Volts), EU



Signal detection / Averaging

- RMS
- Peak (true peak)
- Peak-peak (true peak-peak)
- Calculated peak
- Calculated peak-peak
- CREST factor
- Averaging: RMS, Time-synchronous, Peak Hold, Exponential

Measuring tasks

- Overalls (total vibration and rolling-element bearing)
- Overalls against speed $f(n)$ and time $f(t)$
- Max X/Y (2-channel function)
- FFT spectrum (100 to 25,600 lines representable)
- Envelope spectrum (BCS, SED)
- Orbit (2-channel function)
- Time signal (raw signal) of vibration and reference signal
- Cross-Channel-Phase (2-channel function)
- Transfer function
- Process value (DC, Volt)
- Distance (DC)
- Phase
- Speed
- Tracking (Bode, Nyquist, waterfall, spectrogram)
- Order analysis



Sensors

- Vibration acceleration
- Vibration velocity
- Vibration displacement
- Process (DC, Volt)
- AC/DC sensors
- Speed / reference sensor
- Voltage
- Sensor supply: CCS (Constant Current Supply) typically 2.4 mA (2.0 mA minimum)
- OK monitoring
- Sensor check: Position of bias voltage (automatic over- and undervoltage bias voltage check)

Input channels

- 4 x vibration channels (1/X, 2/Y, 3/Z and 4/R) + reference / speed, Triax support 1/X, 2/Y, 3/Z @CH1
- In potentially explosive atmospheres only VIBROPORT 80 E with maximum 3 x vibration channels 1/X, 2/Y, 3/Z (Triax) + reference / speed
- Channel CH1: Measuring channel 1 or Triax / triple split adapter 1, 2, 3 (vibration)
- Channel CH2: Measuring channel 2 (vibration)
- Channel USB-HOST/ CH R: Measuring channel 4 (vibration), impact hammer, earphones (Audio out), USB-Out - (not permitted for operation in potentially explosive atmospheres)
- Channel USB-DEV / TRIG / PWR: Speed/reference and USB connection to PC.



Measuring range

- Input channels: Nominal maximum ± 25 volt peak-peak (overvoltage protection ± 50 V, transient)
- Input amplification: Sensor unit, Autorange or maximum 25V
- Dynamic range: >90 dB
- Frequency range: DC voltages, AC = 0.18 Hz to 80 kHz (max. frequency dependent on number of channels)
- In analyzer / FFT module: Low-pass cut-off frequency; 1-/2-chl: DC up to 80 kHz (DC component not included in spectrum / is filtered out), 3/4-chl: DC up to 40 kHz
- In overalls module:
Only path [A] active:
1-chl: 0.18 Hz to 80 kHz, 2-chl: 0.18 Hz to 40 kHz, 3/4-chl: 0.18 to 20 kHz, path
[A] + path [B] active:
1-chl: 0.18 Hz to 40 kHz, 2-chl: 0.18 Hz to 20 kHz, 3/4-chl: 0.18 to 10 kHz
- Speed: 1 to 250,000 rpm / min 0.1 Hz to max 10 kHz
- Reference (speed and phase tracking): min. 0.1 Hz to max. 10 kHz
- Trigger (reference acquisition): Automatic, manual
- Bearing condition: BCUp (maximum two-channel operation), ECUp, acceleration band-pass, BCS, SED
- Envelope filter: 612.5 - 1250Hz, 1250 - 2500Hz, 2500 - 5000Hz, 5K - 10KHz, 10k - 20KHz, 40 - 80Hz, 80 - 160Hz, 160 - 315Hz, 315 - 630Hz, 20k - 40KHz, 50 - 1000Hz, 500 - 10KHz, 1KHz - 10kHz, 5k - 40kHz and 15k - 42kHz (BCUp, BCS)



Measuring accuracies

- Overalls (AC, broad-band): 5% amplitude accuracy
- Vector amplitude (AC, narrow-band): 5% amplitude accuracy
- Phase: +-3 degrees for the first three peaks and then +-6 degrees for all following peaks @60Hz
- DC: 1% amplitude total accuracy
- Speed: 1% tolerance in rpm or better (typically: 1-2 rpm @3000 rpm; 3-5 rpm @ 100000 rpm)

Housing

- Dimensions: 220 x 220 x 71 mm
- Weight: 1,54 kg
- Display: 6.4" TFT VGA, color LCD, backlighting (640x480, 8-bit colors)
- LED display: blue, green, yellow and red

Battery

- Lithium-ion battery
- 6600 mAh
- Operating time 8 hours (typical)

Memory

- Internal: 128 MB DDR SDRAM (approx. 80MB usable)
- External: max.16 GB SD/SDHC card (max. 2 GB per report file)



Environment

- Class of protection: IP65 (dust and splash protected, EN60529)
- Drop height: 1.2 m (4 ft) – according to MIL STD-810F
- Operating temperature VP-80: –10 to +60 °C (+14 to 140 °F)
- Important: Maximum permissible ambient temperature VP-80 E: –10 to +50 °C (+14 to 122 °F)
- Storage temperature VP-80 / VP-80 E: –20 to +60 °C (-4 to +140 °F)
- Air humidity VP-80 / VP-80 E: 10 to 90% rel. humidity, non-condensing 0 to +50 °C (+32 to +122 °F)
- Note operating temperature of AC-7001 power supply module
- Shaking/vibration: according to MIL STD-810

Approvals/certificates

- VIBROPORT 80 / VIBROPORT 80 E: CE
- Power supply: CE
- Docking station: CE
- C-Tick registration number see name plate on VIBROPORT 80
- WEEE Reg.-No. DE 69572330 product category / application area 9



Communication

- USB (direct connection via connection socket of USB device/TRIG/PWR or via docking station)
- Microsoft Windows® XP: ActiveSync, Windows 7: Mobile Device Center
- Operating system: Microsoft Windows® Embedded CE 6.0
- Processor: Marvell 806 MHz PXA320
- DSP: Motorola Freescale DSP56311
- Time block length/sample values: 256 - 65,536 sample values

Docking station / power supply module

- Input voltage 12V, 5A DC (note enclosed AC-7001 Operating Instructions)
- Charging of battery via docking station or directly with external power supply module (the docking station and power supply module must not be used in potentially explosive atmospheres).



6 Basic Operation

6.1 Overview of hardware for the VIBROPORT 80

6.1.1 Front

In the following you will find a detailed overview of the operating controls for the VIBROPORT 80.



Fig. 1 Front of the VP-80

- [1] Input keys (fire keys)
- [2] Indicator lights (4x LED)
- [3] Display
- [4] Function keys (1 to 6)

- [5] On/Off key
- [6] Cursor keys (left, right, up, down)
- [7] Alphanumeric keypad







Input keys (fire keys)

The three red input keys (*fire keys*) are used to select modules, confirm inputs and sometimes to start measurements.

Indicator lights (4x LED)

The VIBROPORT 80 has four indicator lights (LEDs) in the colors blue, red, orange and green. These indicate the status as shown in the following LED table.

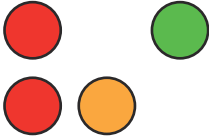
Display	Explanation
	Switch-on of the VIBROPORT 80 Momentary display when the VIBROPORT 80 is switched on.
	Battery charging The battery is being charged.
	Data acquisition completed Data acquisition has been successfully completed and no errors are present.
	Data acquisition running Data acquisition is in progress and no errors are present.
	Data acquisition defective Data acquisition is defective, for example a sensor error or an overload is present. The color combinations depend on the point in time at which the respective error occurs.





Tab. 3 Indicator lights



Display

You can navigate, make settings and perform measuring tasks in the display. The measuring results are displayed here in the form of numeric or graphic displays.

The status of the VIBROPORT 80 is also indicated here by means of symbols.

Picto-gram	Explanation
	When the battery is fully charged, the symbol of a battery with full bars is displayed.
	If you press the point key, the charge state of the battery is displayed for approx. 3 seconds. In addition, if the charge state falls below a defined level, a low battery charge state is indicated automatically. This indication is repeated if the charge state decreases further.
	When the device is connected to the network, a socket symbol appears.
	The diskette symbol means that the device has an SD storage card inserted.

Tab. 4 Display symbols

Function keys (1 to 6)

The six function keys F1 to F6 (from left to right) correspond to the softkeys shown in the display. Pressing the function key executes the respective application, for example: HELP, SYSTEM SETUP or INFO.

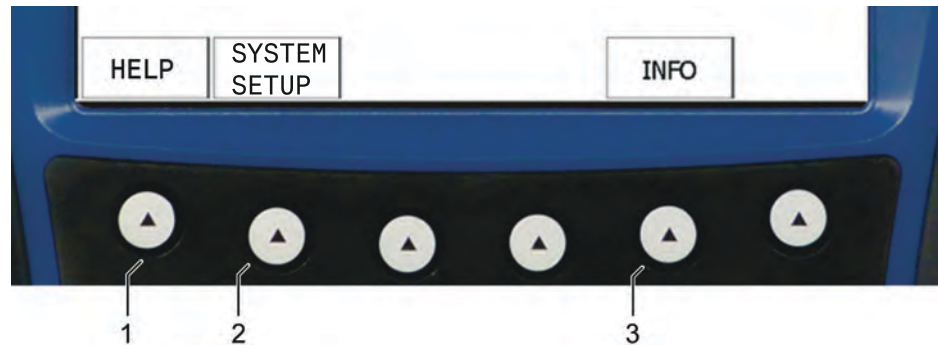

Fig. 2 Function keys

[1] Function key 1 / HELP

[3] Function key 5 / INFO

[2] Function key 2 /
SYSTEM SETUP

On/Off key

The VIBROPORT 80 is switched on and off with the On/Off key. Press this key for approx. 2 to 3 seconds to switch the VIBROPORT 80 off.



Note!

If the battery is completely discharged, you must recharge the device for at least an hour before you can operate the VP-80 again.

The content of the memory and the called up module are buffered until the device is next switched on.



Note!

If a function key in the display has no softkey assigned to it, then this key has no function.



Cursor keys

Pictogram	Description
	The cursor keys enable you to navigate through the menus and settings and to select functions / measuring modules.
	Navigating in the menus Navigate to the desired item in the menus with the → (right), ← (left), ↑ (up) and ↓ (down) cursor keys.
	Navigating in the settings Navigate to the desired setting in the settings with the ↑ (up) and ↓ (down) cursor keys. Press the → (right) cursor key to make settings or inputs.
	Input For menu items in which an input is expected, the input is started by pressing the → (right) cursor key. Depending on the selected setting a drop-down menu opens in which you can make a selection, or data can be entered in input fields using the alphanumeric keypad.
	Confirm input / Start modules The modules are started by pressing the input key (fire key). To adopt the settings, press the ← (left) cursor key or one of the three input keys (fire keys).

Tab. 5 Cursor keys



Alphanumeric keypad

The alphanumeric keypad is used for entering letters and numbers.

- **Letters**

To enter letters, quickly press repeatedly on the key that represents the relevant letter.

- **Numbers**

To enter numbers, press the relevant number key.



Note!

If several identical numbers are entered in succession, you must wait briefly between entries. Otherwise letters will be entered.

6.1.2 Connection plate

The connection plate of the VIBROPORT 80 contains four connections (sockets) for connecting sensors, power supply modules and USB devices.



Note!

In addition to the cables and sensors available from Brüel & Kjær Vibro GmbH, cables and sensors from other suppliers can also be connected. The operating authority is responsible for cables, sensors and accessories that are not supplied by Brüel & Kjær Vibro GmbH. Brüel & Kjær Vibro GmbH cannot accept any liability for products purchased from other manufacturers.

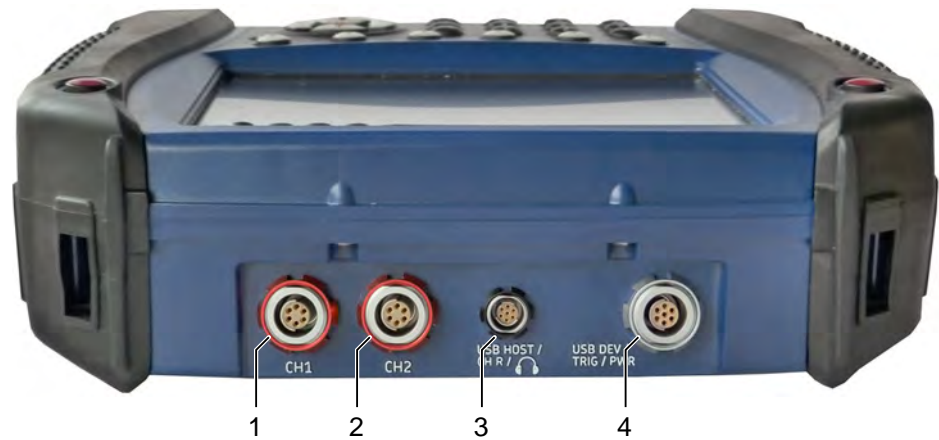
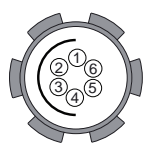

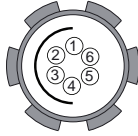

Fig. 3 Connection plate

[1] Channel CH 1
 [2] Channel CH 2

[3] Channel USB HOST / CH
 R / Earphones
 [4] Channel USB device /
 TRIG / PWR

Connection	Pin assignment	Standard sensors
Channel CH 1 	(1) Measuring channel 1/X, (2) Measuring channel 2/Y, (3) Digital Gnd, (4) +5V-EXT, (5) Analog Gnd, (6) Measuring channel 3/Z Measuring channels 1X, 2Y, 3Z: (CCS supply, AC/DC input)	AS(A)-063 + AC-1393 / AC-1384 or in combination with AC-1382 (Triax)



Con- nec- tion	Pin assignment	Standard sen- sors
Channel CH 2 	(1) Measuring channel 2/Y, (2) N/C, (3) Digital Gnd, (4) +5V-EXT, (5) AnalogGnd, (6) +5V-Tacho-Out Measuring channel 2/Y: (CCS, AC/DC input)	AS(A)-063 + AC-1393 / AC-1384
Channel CH R / USB Host / Ear- phones 	(1) Measuring channel 4/R, (2) USB BVUS, (3) USB-Host D+, (4) USB-Host D-, (5) Gnd, (6) Audio Out, (7) Analog Gnd Measuring channel 4/R: (CCS supply, AC/DC input), (with VIBROPORT 80 E do not use in potentially explosive atmospheres / Zone 2)	Impact hammer AC-7501 + AC- 1387 or alterna- tively AS-063 + AC-1386
Channel USB DEV / TRIG /PWR 	(1) EXT-DC-IN, (2) USB-Host Digital+, (3) USB-Host Digital-, (4) Digital Gnd, (5) EXT-TRIG-AUX, (6) USBV, (7) +5V-EXT	P(A)-98 + AC- 1388 or AC-1389

Tab. 6 Connections



Earphones

The FFT-Analyzer and Balancer modules support the output of an audio signal and allow you to use earphones as a diagnostic tool.



Note!

A multitude of further sensors can be connected with corresponding adapters from Brüel & Kjær Vibro GmbH!



Vibration measurements	Channel CH1	Channel CH2	Channel CHR	Channel USB DEV/ TRIG/PWR
Single-channel measurement	Measuring channel 1			(Speed)
Two-channel measurement	Measuring channel 1	Measuring channel 2		(Speed)
Three-channel measurement	Measuring channel 1, 2, 3			(Speed)
Four-channel measurement	Measuring channel 1, 2, 3		Measuring channel 4	(Speed)
Transfer function	Measuring channel 1, (2), (3)	Measuring channel 2	Impact hammer	

Tab. 7 Overview of channels



6.1.3 Power supply module



WARNING!

Explosive atmosphere!

Do not use the power supply module in potentially explosive atmospheres.

This can cause explosions, resulting in damage to property and injuries.

- Never use the power supply module in potentially explosive atmospheres.
-



Note!

The enclosed operating instructions for the AC-7001 power supply module must be read, understood and complied with. Pay special attention to the operating temperature of the power supply module.



Note!

Use the power supply module to charge the battery. Do not cover the power supply module.



Note!

Before using the VIBROPORT 80 for the first time, the fitted battery must be charged for at least 24 hours, so that it can reach its full capacity.

To charge the battery fitted in the VIBROPORT 80 use the AC-7001 power supply module in conjunction with the docking station, or an AC-1389 splitter cable (special accessory provided in the scope of supply).

Adapter

The power supply module is equipped with different adapters, which allow the VP-80 to also be connected to other power grids which do not use the connector (type F / CEE 7/4).

To change the adapter, proceed as follows:



6.1.4 Battery



Note!

Only the rechargeable battery / storage battery BP-15 (AC-7003) may be fitted and used in the VIBROPORT 80.
Only the rechargeable battery / storage battery BP-15-CC (AC-7004) may be fitted and used in the VIBROPORT 80 E.



Note!

The battery connections must not be short-circuited! This will cause damage to the battery / the VIBROPORT 80.

Charging time

The battery charging time is generally three to four hours.

If the battery is completely discharged, you must charge the device for at least an hour before you can operate the VP-80 again.

The device can be charged in two ways:

- via the docking station or
- via the power supply module.

6.1.4.1 Charging the battery via the docking station

**WARNING!****Explosive atmosphere!**

Do not use the docking station and power supply module in potentially explosive atmospheres.

This can cause explosions, resulting in damage to property and injuries.

- Never use the docking station and power supply module in potentially explosive atmospheres.
-

**Note!**

Make sure that the VIBROPORT 80 is correctly positioned in the docking station charging cradle, as otherwise the battery will not be charged correctly. Note the indicator light display (LEDs)!



Fig. 5 Power supply

- Connect the power supply module to the docking station.
- Insert the power supply module into a socket.
- Insert the VIBROPORT 80 into the docking station.
- ⇒ The red charging indicator light indicates that the battery is charging.
- ⇒ The battery is charged when the red charging indicator light goes out.



6.1.4.2 Charging the battery via the power supply module



WARNING!

Explosive atmosphere!

Do not charge the battery of the VIBROPORT 80 E in potentially explosive atmospheres. The power supply module and docking station must not be operated in Ex zones.

This can cause explosions, resulting in damage to property and injuries.

- Therefore only charge the battery outside potentially explosive atmospheres.
- Never use the power supply module and docking station in potentially explosive atmospheres.

To charge the battery fitted in the VIBROPORT 80, use the AC-7001 power supply module in conjunction with the AC-1389 USB power supply splitter cable (provided in the scope of supply).

The AC-1389 splitter cable comprises three connections:

- USB connector
- 7-pole connector for VP-80 connection USB DEV/TRIG/PWR
- Low voltage connector for power supply module

Charge the VP-80:

- Connect the two low voltage connectors of the power supply module and the splitter cable (AC-1389) together.
 - Connect the splitter cable to the VP-80 (connection USB DEV/TRIG/PWR) using the 7-pole connector.
 - Insert the power supply module into a socket.
- ⇒ The VIBROPORT 80 is charged. The red indicator light indicates that the battery is charging.



6.1.4.3 Changing the battery



WARNING!

Explosive atmosphere!

Do not change the battery and the power supply module of the device in potentially explosive atmospheres.

This can cause explosions, resulting in damage to property and injuries.

- Therefore only change the battery outside potentially explosive atmospheres.
 - Only use the power supply module outside potentially explosive atmospheres.
-



Note!

The fitted battery has a long service life and only needs to be changed in the event of a defect. A defect is present if the battery cannot be charged sufficiently.



Note!

The battery may only be changed when the device is switched off. Otherwise the device may be damaged.



Note!

The internal clock and the system control are maintained for 10 minutes when changing the battery. They must be reset at the end of this time.

Change the battery of the VP-80 as follows:

- Set up the VP-80.
- Unscrew the four screws of the battery cover.
- Remove the battery cover.
- Disconnect the battery from the VP-80.
- Insert the new battery.
- Put on the battery cover.
- Screw the four screws into the battery cover.



⇒ You have changed the battery.

6.1.5 Docking station

Additional connections for the power supply and for USB devices can be found on the back of the docking station of the VIBROPORT 80.



Fig. 6 Docking station

- [1] Connection of external power supply module AC-7001
- [2] USB connection for connecting to a PC (Report & EXaminer software / data exchange)

- [3] USB connection for connecting a further USB device – not active and therefore cannot be used (for future developments)

Connection of external AC-7001 power supply module

The external AC-7001 power supply module is connected here, if it is located in the docking station.



USB connection for connecting to a computer

Here you can connect the VIBROPORT 80 in the docking station to a PC via USB connection. Data can then be exchanged between the VIBROPORT 80 and the PC and / or further processed and analyzed on the PC using the Report & EXaminer software.

USB connection for connecting a further USB device

This connection is currently not active and therefore cannot be used (intended for future developments).

6.1.6 Folding out the bracket

If you wish to set up and operate the VP-80 on a work surface, it can be positioned at an ergonomically favorable angle using a bracket on the back.



Fig. 7 Folding out the bracket

- Release the bracket from the holder by pressing the clips down at both holding points and pulling the bracket forward.
- Fold out the bracket.
- Set up the VP-80.



6.1.7 SD storage card slot



Note!

In addition to the internal memory, the VIBROPORT 80 has a storage card slot for inserting an SD storage card with up to 16 GB storage capacity. The recommended supplier is SanDisk (the “Secure Digital Card SDSDx-yyy” type is the only one that can be used for the EX zone!).

The storage card slot is located on the bottom. It is protected from external influences by a cover. This cover / IP protection complies with class of protection IP65 and is locked by two screws.



Note!

Make sure that the seal and cover of the SD storage card slot are always present and correctly inserted. This is essential to ensure protection from dust, water and other external influences.



Fig. 8 Storage card slot

6.1.8 Inserting the SD storage card



WARNING!

Explosive atmosphere!

The AC-7310 cover (for SD storage card slot and charging pins) may only be opened outside potentially explosive atmospheres.

Do not insert or replace the SD storage card in an explosive atmosphere.

This can cause explosions, resulting in damage to property and injuries.

- Do not open the cover in potentially explosive atmospheres.
- Only insert and replace the SD storage card in non-hazardous atmospheres.

Insert the storage card for the VIBROPORT 80 as follows:

- ❑ Loosen the two holding screws of the card slot by giving a quarter turn clockwise (90°) (see following illustration).



Fig. 9 Inserting the SD storage card

- ❑ Push the SD storage card into the card slot, so that the contacts of the storage card point upwards.
- ⇒ Once it has engaged, the storage card will remain in the correct position.



- ❑ Mount the card slot cover and lock it with the two holding screws.
- ⇒ You have inserted the SD storage card.

6.2 Connecting the VIBROPORT 80 to the PC

6.2.1 Connecting via the USB interface

Connect the VIBROPORT 80 to a PC as follows:

Directly via the USB connection:

- ❑ Insert the Y-cable (AC-1389) into the USB DEV / TRIG / PWR input of the VP-80.
- ❑ Connect the power supply module to the socket (optional).
- ❑ Plug the USB connection into the PC.
- ⇒ Data exchange with the PC can begin.

Via the docking station:

- ❑ Place the VP-80 in the docking station.
- ❑ Connect the docking station to the socket by means of the power supply module (optional).
- ❑ Connect the docking station and the PC using the USB cable provided.
- ⇒ Data exchange with the PC can begin.



6.2.2 Synchronization software



Note!

When the VIBROPORT 80 is connected to the PC, no data from the operating system, firmware or other important data may be deleted. This would cancel out the functionality of the VP-80 and result in voiding of the warranty.



Note!

If problems occur when detecting the VIBROPORT 80 on the PC, it can be helpful to insert and remove the USB connection plug on the PC, and to switch the device on and off a number of times.



Note!

When using/installing the synchronization software, please note that the software may take a while to start, as the necessary drivers and updates must be downloaded.

Different programs are required to synchronize an IBM-compatible PC with the VP-80, depending on the operating system. After installing the software the device can be controlled and data exchanged via a Microsoft Windows window.

- **Microsoft Windows Active Sync (free download) / Microsoft Windows 2000 / Microsoft Windows XP**
 - This software serves as synchronization software for devices like the VIBROPORT 80, which are based on Microsoft Windows Mobile. It may be necessary to download Microsoft Windows updates during installation.
 - When the device has been successfully connected, this is shown by the indication "Connected".



- **Microsoft Windows Mobile Device Center (free download) / Microsoft Windows 7 (32 / 64 bit)**
 - This software serves as synchronization software for devices like the VIBROPORT 80, which are based on Microsoft Windows Mobile. It may be necessary to download Microsoft Windows Updates during installation.
 - This tool can be downloaded free of charge if it is not already installed. Under Microsoft Windows 7, the Mobile Device Center corresponds to Tool Active Sync under Microsoft Windows XP.
- **CMC USB driver**
 - This driver is required for communication with the VIBROPORT 80. Install it manually using the supplied CD and execute the installed program after installation.



Note!

Microsoft Windows may require a .net Framework 3.5 installation or higher, if this has not yet been installed on your PC.

6.2.3 Report & EXaminer Software

This is a high-performance Report & EXaminer software program with report and analysis functions for the Microsoft Windows operating system (IBM PC-compatible). This completes the service package for the VP-80.

The standard version is already contained in the two starter packages, Analyzer Select and Balancer Select.

Reports can be generated quickly and easily with the Report & EXaminer software from measurements stored in the measuring instrument.

The VIBROPORT 80 is connected to the PC by means of a USB interface.

The optional premium version enables you to analyze previously stored time signal data sets (.wav files) so they can be post-processed for calculating FFT and waterfall spectra. For the analysis of rolling-element bearing defects, Report & EXa-



miner software provides an OEM database that lists the characteristic fault frequencies of all common rolling-element bearing manufacturers.



Note!

For more detailed information please use the Report & EXaminer Software Manual on the supplied CD.

VP-80 directory structure in conjunction with Report & EXaminer software

In conjunction with the Report & EXaminer software module names and analysis software, the VIBROPORT 80 has various special features in the implemented directory structure. As the VIBROPORT 80 platform is a Windows system, you can access the directories of the VIBROPORT 80 directly.



Note!

Retain the existing directory structure. Never delete or move directories. Do not create new directories or folders. Any change to the original directory structure can adversely affect the functioning of the VIBROPORT 80.

The directory names are not identical to the relevant module names. However, unloading the measuring data is easy, as Report & EXaminer software correctly associates the measurements from the respective modules with the specific directory locations.

To enable you to easily find the desired data when directly accessing the VIBROPORT 80, we shall now explain the concept and the directory structure in more detail.

Directory structure and measuring file types

Each module has two root directories which are derived from the storage media on the VIBROPORT 80:

- Internal Disk (internal storage medium)



- Storage Card (external, i.e. removable storage medium / SD card)

Files in *.wav format from the time signal and tracking modules are physically present but not visible. An additional *.csv file is stored in the directory instead. The *.wav file is used for unloading to Report & EXaminer software and for data analysis.

The following table provides an overview of the assignment of measuring files from the modules to the directory structure on the VIBROPORT 80:

Overalls, FFT Analysis, Balancing, Tracking and Transfer Function modules

Module	Directory path and directory name on VP-80	Explanation and file format
Overalls	\Internal Disk\Overall \Storage Card\Overall	*.csv
FFT Analysis	\Internal Disk\Analyser \Storage Card\Analyser	*.csv. This directory structure contains the subfolders "Recorder" and "ConfCheck". Some data from the "Time Signal" and "Acceptance Test" modules are stored here. Do not save your measuring data in the two subfolders "Recorder" and "ConfCheck", but directly in the FFT-Analyser folder, i.e. directly under Internal Disk or Storage Card.



Module	Directory path and directory name on VP-80	Explanation and file format
Balancer	\Internal Disk\Balance \Storage Card\Balance	*.BAL
Tracking	\Internal Disk\RuCd \Storage Card\RUCD	*.csv and *.wav
Transfer Function	\Internal Disk\FRF \Storage Card\FRF	*.csv

Time Signal, Acceptance Test and Sensor Setup modules

The Time Signal and Acceptance Test modules save some measuring data in the FFT Analysis module. It is thus possible, for example, to view recorded spectra from a performed acceptance test directly on the VIBROPORT 80.

Module	Directory path and directory name on VP-80	Explanation and file format
Time Signal	\Internal Disk\Analyser\Recorder \Storage Card\Analyser\Recorder	*.csv saves approx. 1 s of measuring data and the parameter settings.
	\Internal Disk\Analyser\Recorder \Storage Card	*.wav saves the complete measuring data set. Important: For Storage Card, the measuring data set is stored directly in the root directory



Module	Directory path and directory name on VP-80	Explanation and file format
Acceptance Test	\Internal Disk\Conf-Check\Saved \Storage Card\Conf-Check\Saved	Results are stored as *.CCR. Optional – depending on the *.CCS test template – the results are also stored as *.csv.
	\Internal Disk\Analyser\ConfCheck	Optional – depending on the *.CCS test template – spectra are stored here and can be viewed directly in the FFT Analysis module.
	\Internal Disk\Conf-Check\<Template directory>	*.CCS test templates are read but never written from here. (There are standard templates and user templates.)
Sensor Setup	\Internal Disk\System	Predefined sensors are stored in the Sensor Override-List.cfg file

Note!



In the Time Signal and Tracking modules it is possible to explicitly select the storage location (Internal Disk or Storage Card) in the setup before a measurement, ignoring the setting in the system setup. Since the *.wav files can take up a lot of storage space (up to 2GB maximum per *.wav file), the option of being able to explicitly select the storage location is useful.



6.3 Reset function

If the VP-80 does not operate correctly, it can be reset with the aid of the reset functions.

6.3.1 Performing a warm start

A warm start of the VP-80 is a software reset. This ends the current processes and restarts the device. All settings are retained.

- Press and hold down the function keys 2, 7, 8, 9 simultaneously for two to three seconds.
- ⇒ The VIBROPORT 80 restarts.

6.3.2 Performing a cold start

A cold start of the VP-80 resets the device to delivery status.



WARNING!

Explosive atmosphere!

The housing must be open when performing a cold start.

This can cause explosions, resulting in damage to property and injuries.

- Do not do this in a potentially explosive atmosphere.



Note!

During a cold start only the date, time and time zone are reset to default values.

Firmware states and measuring data are retained.



- ❑ Loosen the four screws of the battery cover by 90°.
- ❑ Open the rear battery cover.
- ❑ Open the Velcro straps.
- ❑ Remove the battery pack from the compartment. The battery can remain connected to the device.
- ❑ Press the reset key using a pointed object.
- ⇒ The VIBROPORT 80 restarts.
- ❑ Put the battery back in the battery compartment.
- ❑ Secure the battery with the Velcro straps.
- ❑ Put the cover back on the battery compartment and lock the compartment with the four screws.



7 Operator Interface

This chapter provides a detailed overview of using the operator interface of the VIBROPORT 80 and the basic operating concept.

The general mode of functioning implemented by the firmware is also described.





Note!

The lists / settings in the operator interface are dynamic. The relevant data are faded in depending on the selection made.

7.1 Explanation of symbols

The symbols listed here are used in the operator interface of the VIBROPORT 80 to indicate the status of the respective function. This enables easy and intuitive operation.

Picto-gram	Explanation
	Blue pictograms Blue pictograms represent different measuring modules or correspond to predefined measuring tasks.
	Gray pictograms Gray pictograms represent measuring modules which are already installed but have not yet been activated or licensed.
	Red pictograms Red pictograms are assigned for help, new non-predefined measuring tasks, reports, <i>Sensor Setup</i> and <i>System Setup</i> .

Tab. 8 Explanation of symbols

7.2 Structure of the operator interface

The screen of the VIBROPORT 80 is dynamically divided in up to four areas. These offer different functions, which will now be described in more detail.

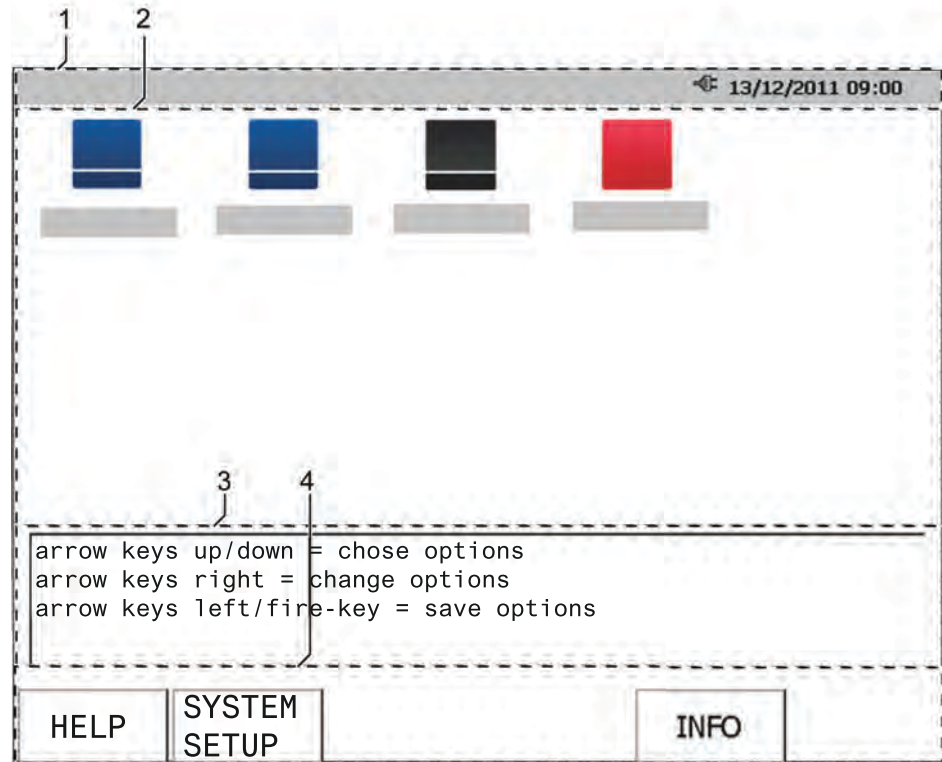

Fig. 10 Structure of the operator interface

[1] Header line

[2] Work area / Masks

[3] Status lines

[4] Function keys (softkeys)



Note!

This is an exemplary, generalized illustration. The *main mask* (start mask) of the VIBROPORT 80 has no status line.



Header line

The header line contains the following information:

- The name of the current mask is shown on the left of the info line.
- If the VIBROPORT 80 has an SD storage card, this is indicated by a diskette symbol.
- The state of the fitted battery or the connection to the power supply module is displayed on the right.
- The current date and time are displayed on the far right.

Work area / Masks

The menus, measuring modules, measuring tasks and the masks with content (diagrams, measurements, text) are displayed in this area.

Status line

The status line provides special operating instructions for the current display.

Function keys (softkeys)

The softkeys show context-dependent functions for the respective menu or open another menu.

Pressing the function key executes the displayed function or opens another menu.



7.3 Main mask

The main mask appears when the VIBROPORT 80 is switched on. You can access all of your modules from here.

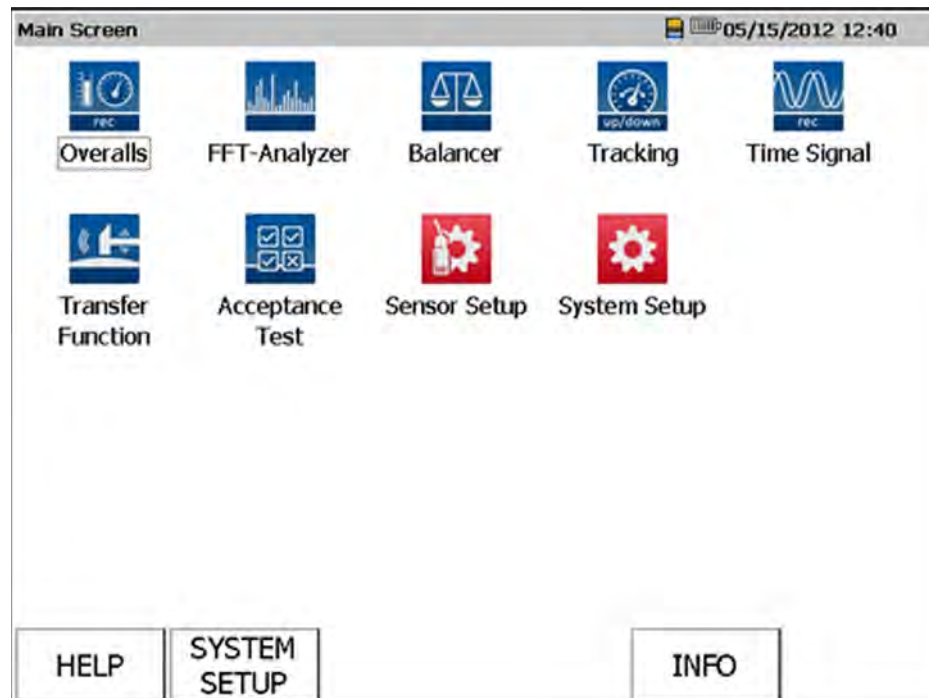

Fig. 11 Main mask

Note!



Only some of the displayed modules can be installed, depending on the licensed features of your VP-80.

Cursor keys

The desired module is selected by pressing the cursor keys (left, right, top, bottom).

Input keys (fire keys)

The selected module is started by pressing one of the three input keys (fire keys).



Help, System Setup and Information (INFO)

You can use the softkeys
HELP, SYSTEM SETUP (the general *system setup*) and
INFO at the bottom of the screen to call up basic information
on the VIBROPORT 80.

7.4 Licensing

You can retrospectively purchase and install modules on your
VP-80. Modules which are not yet installed have a gray back-
ground.

- In the initial mask, go to the module that you wish to install.
- Press one of the three fire keys.
 - ⇒ An input window opens
- Enter the license number provided by B&K Vibro.
- Confirm the input with OK.



Note!

The following module descriptions refer to the complete,
licensed functionality.



7.5 Module overview

Picto-gram	Description of the module
	<p>Overalls</p> <p>The Overalls Module allows you to analyze the overall condition of a machine and compare it to the limit values according to DIN ISO 10816 or the manufacturer's data and empirical values, for example. A single overall can provide information on the overall condition of a machine, enabling a basic condition assessment to be carried out easily and efficiently. In addition to the vibration overalls, overalls for assessing the rolling-element bearing condition (BCUp, ECUp) can also be recorded and evaluated.</p> <p>Up to four measuring channels plus speed are available. Each measuring channel has two digital signal processing paths A and B. Several measurements can thus be performed in parallel.</p> <p>In addition, the Overalls Module supports measurement and recording of overalls as a function of speed $f(n)$ or as a function of time $f(t)$.</p>



Picto-gram	Description of the module
	<p>FFT-Analyzer</p> <p>The FFT-Analyzer Module allows you to break down an overall vibration (mixture of vibrations) into its individual harmonic components. Different spectral lines are determined with their own specific frequency and amplitude. In relation to the overalls BCUp and ECUp for the rolling-element bearing condition it is possible to calculate the envelope spectra BCS and SED, in which the amplitudes at characteristic fault frequencies correspond to the degree of damage of a component or bearing.</p> <p>In simple terms, the amplitude therefore stands for the degree of damage and the frequency for the damaged component.</p> <p>Faults such as imbalance, transmission damage, poor alignment or rolling-element bearing damage can thus be diagnosed reliably.</p>





Picto-gram	Description of the module
	<p>Balancer</p> <p>The majority of vibration problems on machines can be traced back to rotor imbalances.</p> <p>The Balancer Module allows you to balance installed rotors (field balancing). This means no disassembly or transport of the rotor, consideration of the installation situation and balancing irrespective of the size and weight of the rotor.</p> <p>For better orientation during the execution of balancing, you can choose between a clear representation of the balancing process in table form or individual measuring masks (polar plots, numeric display with bar graph). In addition to basic 1-/2-plane field balancing (static/dynamic), the module offers 1-/2-plane balancing with prognosis, 2-plane balancing with just one vibration sensor and free selection of the correction method: polar, components, fixed weight.</p>

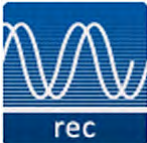



Picto-gram	Description of the module
	<p>Tracking</p> <p>Tracking is carried out during operation of the machine and serves to analyze the rotor frequency-induced vibration components and their harmonics with speed variation. The Tracking measuring module can be utilized for both run-up and coast-down of the machine.</p> <p>The raw vibration signal and the speed are recorded during run-up and coast-down. Up to three measuring channels plus speed are supported.</p> <p>After the measurement, you can define in a setup which method you wish to use to evaluate respectively to post-process the recorded signals. As the raw vibration signal is available, you can repeat the analysis as often as you like with different setups.</p> <p>The results of this so-called post-processing can be viewed using Bode, Nyquist, FFT waterfall, spectrogram or table view options.</p>
	<p>Time Signal</p> <p>The Time Signal Module enables the user to record a raw signal and save it in a standard file format (.wav). This format permits subsequent post-analysis by, for example, the Report & EXaminer software or MatLab™.</p> <p>Up to 4 vibration input channels or 3 vibration input channels plus a speed reference are supported.</p>



Picto-gram	Description of the module
	<p>Transfer Function</p> <p>The Transfer Function Module enables you to carry out structural tests on machines with shafts that are not rotating and to analyze immovable objects such as, e.g. foundations or frameworks. The transfer function is determined using an impact hammer with built-in load sensor, and is given by the ratio between the input signal (load introduced by the hammer hits) and the output signal (measured vibration), which is shown in the form of a Bode diagram. The coherence of the measurement is also displayed; this is a measure of a largely linear signal transmission, free from interference.</p> <p>In addition to the most well-known transfer functions such as stiffness or mobility, four further input signal to output signal ratios are also available to the user. The acquisition of up to three vibration measuring channels (impulse responses) are also supported.</p>
	<p>Acceptance Test</p> <p>The Acceptance Test Module can be used for quality inspections in batch production (final acceptance), for example. It compares recorded overalls with limit values established by DIN ISO 10816, for example. The module also allows you to draw on predefined or personally defined measuring tasks (format templates for the measuring procedure).</p> <p>Up to 64 frequency bands in the frequency range and 8 alarm levels are supported. The alarm levels are color-coded for a better overview.</p>



Picto-gram	Description of the module
	<p>System Setup</p> <p>In the <i>System Setup</i> you can define the most important global system parameters of the VIBROPORT 80, such as the system of units or the time, for example.</p>
	<p>Sensor Setup</p> <p>In the <i>Sensor Setup</i> you can look at the settings for the sensors predefined in the measuring modules (Brüel & Kjaer Vibro sensors). You can also select or define sensors for the entire system here. These are then available to you in all setups within the modules with the specifications which you have defined.</p> <p>This permits the integration and efficient use of sensors from other manufacturers.</p>



7.6 Softkeys

7.6.1 General



Note!

Softkeys are called up via the respective function keys (F1 to F6).



Note!

The softkeys are dynamic and adapt according to the given mask and situation.

- **Change softkeys**
 - These softkeys change automatically when activated with the function key.
For example: HZ/rpm or EXPAND/REDUCE.
 - **Gray softkeys**
 - When these softkeys are activated with the function key, the function is activated. The softkey appears gray until it is executed again and the function is thus deactivated again.
For example: AVERAGE or RECORD.
 - **Dynamic softkeys**
 - If you change to another level, for example, or navigate to specific measuring tasks, Help or New Measurement, certain softkeys are automatically faded in or out. I.e. the functionality of the softkeys is context-sensitive.
For example: SYSTEM SETUP or START.
-



Note!

The operator interface of the VIBROPORT 80 has four levels in which you can navigate with the softkeys (see following figure).

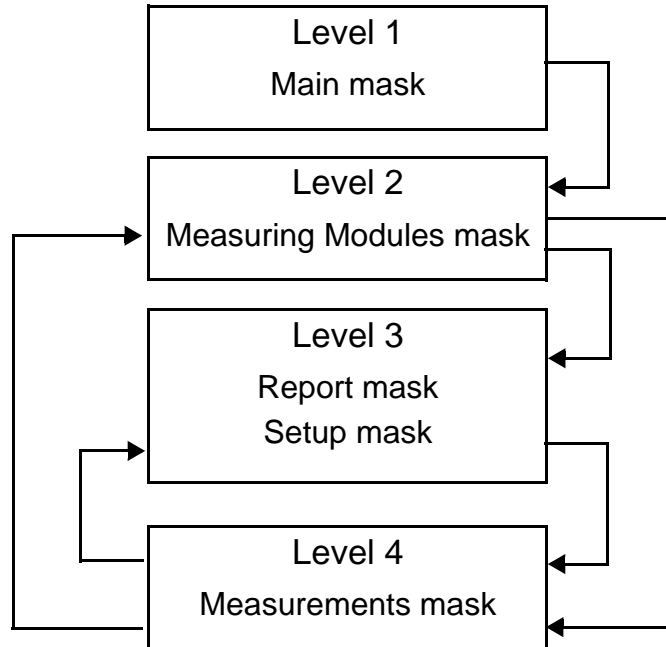

Fig. 12 Levels of the operator interface

7.6.2 Generally valid softkeys

This chapter provides an overview of the functions of the softkeys that are valid for all modules.

HELP

The HELP softkey provides additional information on handling / operation, masks and parameters.

EXIT

The EXIT softkey is used to close masks and measurements. A security query may be displayed when handling the acquired data.

7.6.3 Level 1 / Main mask

The first level / main mask appears after switching on the VIB-ROPORT 80 or exiting a module.



HELP

The online help is called up with this softkey. Here you can obtain information on:

- **Program Manager**
 - Information on the operator interface, basic operation (cursor keys, fire keys) and a brief description of the various modules are displayed here.
 - The INFO softkey is also briefly described (Instrument Unit ID, Firmware Version Number, list of installed modules, free memory in percent and total memory in MB).
- **System Setup**
 - Here a brief description is given of all *System Setup* parameters. The *System Setup* is described in detail in a separate chapter.
- **Using Instrument**
 - This menu item describes the display, the basic operation and the relevant operating controls (alphanumeric keypad, cursor keys, fire keys, 0 key, On/Off switch, warm start, charge state, date/time, and text input).
- **Shortcut Keys**
 - The most important key combinations are described here.
 - Save screenshot as bitmap (0 and P).
 - Display charge state (point key).
 - Change the cursor mode (Single, Harmonic, Single + Harmonic) during FFT measurements (4).
 - Warm start (2789 simultaneously).
 - Mute individual channels for the earphones (6).
 - Adjust the volume of a channel for the earphones (0+ up cursor key / 0+ down cursor key).



- Change between the channels picked up with the ear-phones (0+ left cursor key / 0+ right cursor key).

> GO TO

The respective menu item is started by executing this softkey.

> BACK

Executing this softkey takes you back to the Help start page.

> EXIT

Executing this softkey takes you to the main mask.

SYSTEM SETUP

The most important parameters such as the memory used, the system of units or the time, are defined in the *System Setup*. The *System Setup* is described in detail in a separate chapter.

INFO

When the INFO softkey is executed, additional information on the VIBROPORT 80 and the installed modules / software version and the available memory is displayed.

- **Software version**
 - The unit ID and the date of the last calibration are displayed.
- **Module**
 - Overview of modules with version and build number. This informs you about the (purchased) modules and their currentness.
- **Internal memory**
 - Here the internal memory is displayed in percent and in megabytes (MB).



> INFO

Pressing the displayed INFO softkey again using function key F2 gives you access to further information on the VIBRO-PORT 80. However, this is not relevant for standard use.

7.6.4 Level 2 / Modules



Note!

The softkeys on the second level, i.e. the main masks of the modules, always have the same structure (HELP, SETUP, REPORT, START and EXIT).

When a module is opened / started, the following standard softkeys are available:

HELP

The general functions of the mask / module and its options are described here.

- **Last measurement**
 - Repeat the last measurement carried out in this module with the same setup. In this case you can START the measurement directly or call up the SETUP again.
- **New measurement**
 - New measurement with new setup.
- **Report**
 - Load saved setup or saved data of a measurement.
- **Predefined measurements**
 - All other symbols / icons represent predefined measurements. These can be started directly or started with recalling the setup behind the predefined measurement.

> BACK

This softkey takes you back to the main mask of the module.



SETUP

Select a predefined measurement, the last measurement or a new measurement with the cursor keys.

You can use the SETUP softkey or the *fire key* to call up the respective setup for the selected mask or measuring task and to adjust the setup parameters (for example hardware used, units, high-pass/low-pass, limit frequency, etc.).

The measurement can then be started with the START softkey or the *fire key*.

REPORT

Here you can load, display and manage the saved setup settings, measurements and *.wav files.



Note!

The report is started with the *fire key* or the REPORT softkey. There is no START or SETUP softkey.

START

If you select *Last measurement* or a predefined measurement with the cursor key and activate the START softkey, the measurement is started directly.

If you select a measurement and press the *fire key* or SETUP, a setup opens in which you can edit the settings, before starting the measurement with START.

The START softkey is not available for *New measurement* or *Report*.

EXIT

Activating the EXIT softkey takes you back to the main mask / module overview.



7.6.5 Level 3 / Measurement setup and report mask

Measurements that are started with the fire key open a setup input mask before the measurement, where the settings for the measurement are defined.



Note!

All softkeys are only available here, if a measuring file or setup file has been selected in the report mask!

Measurement setup

HELP

Activating this softkey displays general information on the measurement setup (cursor keys, fire key, softkeys).

The measurement setup parameters are also described in detail here.

DEFAULT

Activating this softkey resets the settings of the measurement setup to the default values.

EXPAND/REDUCE

The EXPAND softkey fades in all setting options for the setup. The REDUCE softkey displays fewer setting options.

STORE

The STORE softkey saves the currently set setup in the *Report* mask so that it can be reused later.

START

The measurement is started with this softkey.

EXIT

The setup is rejected with this softkey.

The settings and measurements can be used again with the OPEN softkey.



Report mask

HELP

A brief description of the softkeys for the *Report* mask is displayed here.

UP

This softkey goes up one level or takes you back to the previous level.

BACKUP

The file selected with the cursor keys is saved by executing this softkey on the SD storage card of the VIBROPORT 80.

DELETE

The file selected with the cursor keys (saved setup/measurement) is deleted after a security query by executing this softkey.

OPEN

If you select a file (saved setup/measurement) and activate this softkey, the setup or measurement is opened and can be viewed and performed again.

EXIT

This softkey returns to the mask of the current module.



7.6.6 Level 4 / Measurements mask

This is the level in which the actual measurements are performed. Although this can be accessed directly from the second level (START softkey on a blue icon), it is normally only accessed from the third level (setup).



Note!

As which function keys and softkeys are available depends on the respective measuring module, the most important softkeys and their function are explained briefly below by way of an example.

AVERAGE

Executing the AVERAGE softkey averages the current / acquired values of the measurement (average value formation). The softkey is displayed with a gray background.

When the softkey is activated again the values are displayed unaveraged once more, and the AVERAGE softkey is displayed without a gray background.

VIEW

Activating this softkey opens a mask for setting the display / representation of the measurement.

Which display / representation can be selected depends on the measurement. Some setting examples are shown below for the OVERALLS module:

- **Numeric display options**
 - Only table [A+B]
 - A+B+bar chart
 - Table [A] CH 1 + CH 2
 - A + bar chart (CH 1)
 - A + bar chart (CH 2)
- **Y-axis display**
 - Linear
 - Logarithmic



LOG / LINEAR

When the LOG softkey is activated the Y-axis is scaled logarithmically and the LINEAR softkey is displayed.

The LINEAR softkey scales the Y-axis linearly.

CPM / HZ

This softkey switches the display between the units rpm (revolutions per minute) and HZ (vibrations per second).

PAUSE/CONT.

If the PAUSE softkey is activated the current measurement is paused but not interrupted, and the CONT. softkey is displayed. The actual measurement continues running in the background.

If the CONT. softkey is activated, the measurement is continued immediately.

EXIT

In the masks in which measurements are performed, the measurements are concluded with the EXIT softkey. A security query then appears with the following options:

- **STORE**
 - When this softkey is activated the measurement can be saved in the *Report* mask.
- **EXIT**
 - The EXIT softkey rejects the current measurement and returns to the main mask of the current module.
- **BACK**
 - Cancels exiting of the measurement and returns to the measurement.



Note!

The following softkeys are only available in the Balancer module!



POLAR / BARGRAPH

When the POLAR softkey is activated balancing is displayed in a polar view, and when the BARGRAPH softkey is activated the vibration values are shown as a bar chart.

TABLE

The TABLE softkey opens the *Summary* mask, which displays the measuring values as a table.



7.7 Measuring data analysis - zoom and cursor keys

You can select individual measuring data values in measurements with the cursor keys and magnify measuring curves with the zoom key. This allows you to view measuring ranges in more detail and analyze them.



Note!

The status line also displays which keys / cursor keys can be used for zooming in, and which other functions are available to you (Peak, Harm. Cursor).

Zoom in X-axis

The X-axis is zoomed in with the plus/minus key. The zoom factor is changed by pressing the key repeatedly. For example, the displayed spectrum of 0 to 1000 Hz is reduced to a section of 0 to 200 Hz.

Zoom in Y-axis

The Y-axis is zoomed in with the cursor keys (up, down). The scaling of the Y-axis is changed. The Up cursor key enlarges the section, while the Down cursor key reduces it.



Note!

Lines / amplitudes are cut off in the representation if they are greater than the currently selected range end value. The numeric display of the frequencies and amplitudes is not influenced by the representation.



Using the cursor keys

During the measurement and when it is finished, information about individual spectral lines/amplitudes can be selected with a cursor.



Note!

The current X/Y position of the cursor is displayed in the top left corner (near the header line). This means that you always know where the cursor is located.

-
- ❑ Activate the cursor function by pressing the cursor key (right, left) once.
 - ❑ Select the desired position by pressing the respective cursor key (right, left).
 - ⇒ The measuring values for the selected position are displayed numerically. Information e.g. on the individual spectral lines (amplitude and frequency) is also displayed.

Miscellaneous keys

- **Harmonic Cursor**
 - The Harmonic Cursor is activated with key 4. Activating this softkey again deactivates the cursor / fades it out.
- **Peak Find Cursor**
 - The Peak Find Cursor is activated with key 7. This cursor jumps to the max. 5 highest peaks in a spectrum. Activating this softkey again and again, cycles through the highest peaks.
- **Change signal**
 - The key combinations 0+Shift up or 0+Shift down change the cursor from one signal to the next, if more than one signal curve is present in a diagram.



7.8 Setup settings

7.8.1 System Setup

You can define the most important system parameters, such as the memory used, the system of units or the time, in the *System Setup* mask.

- ❑ Go to the *Main Mask*.
- ❑ Select the *System Setup* menu item with the cursor keys.
- ❑ Press the *fire key* or the SYSTEM SETUP function key.

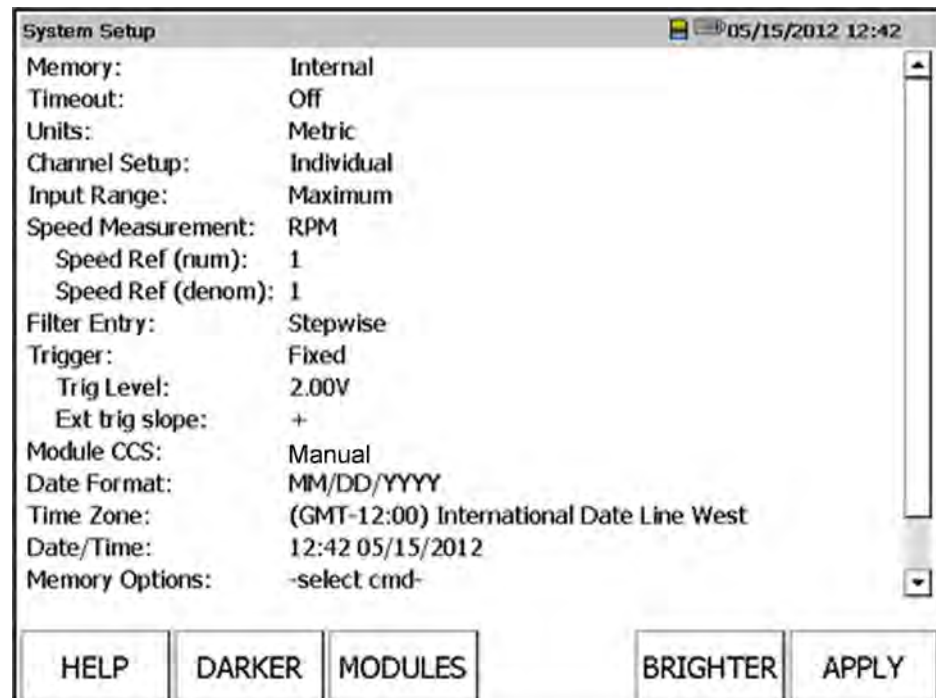

Fig. 13 System Setup

Softkeys

DARKER / BRIGHTER

These softkeys incrementally reduce / increase the screen brightness of the VIBROPORT 80.



MODULES

This softkey calls up the *Module Manager*. This allows you to install, deinstall or hide modules.



Note!

This can irrevocably restrict the functionality of the VIBRO-PORT 80. Special attention should be paid to deinstalling. Deinstalling should only be carried out if you are certain that a module is no longer required. Deinstalling modules will relieve the processor of the VIBROPORT 80 and thus increase processing speed.

- **INSTALL**

- This function may only be executed by our service personnel. Please do not press this key!

- **DEINSTALL**

- This softkey allows you to deinstall purchased modules which you no longer require. Please note the security advice above. Alternatively, you can hide the modules.

- **HIDE/DISPLAY**

- Hiding modules is designed to optimize the *Main Mask*. The modules can be faded in again at any time.
- Hidden modules are identified by square brackets in this mask.

- **SELECT**

- You can select and deselect individual modules with this softkey. Selected modules are indicated by the activated checkbox on the left.
- Selected modules can be installed, deinstalled, displayed and hidden.

OK

Executing the OK softkey saves the settings made in the *System Setup* and takes you back to the Main Mask.



System Setup parameters

Memory

The memory for the measurement data is defined here. You can select the *internal memory (Internal)* or the *SD storage card*, if present. If no SD storage card is installed, *Card [none]* is displayed in the selection.

Timeout

Timeout defines the time after which the VIBROPORT 80 switches off after a key is last pressed. This time is specified in the range of 5 to 20 minutes, but can also be deactivated (*Off*).

Units

Here you can define the system of units used by the VIBROPORT 80. You can select the metric system of units (*Metric*) or the Anglo-saxon system of units (*Imperial*).

Channel setup

The channel setup defines the input channels for the measurement. If *Copy to All* is selected, all input channels must be operated with the same sensor type, which can considerably shorten the measurement setup.

If *Individual* is selected, a separate sensor can be selected for each channel and the measurement setup, including individual parameter settings, consequently has far more entries.

Input range

The input range for the channels is defined here. *Autorange* determines the input range automatically; no input range is displayed in the module.

Maximum sets the max. input range for all modules (except for Tracking and Time Signal); no input range is displayed in the modules.

Sensor units displays an input range in the module, in which this can be individually selected between 0.1 g and xxxx g.



Speed measurement

The speed measurement parameter defines how the rotational speed will be displayed. You can select revolutions per minute (*rpm*) or number of vibrations per second (*Hz*), or the setting can be deactivated (*Inactive*).

Speed Ref (num); (in the Speed Measurement menu)

Here you can set the speed reference numerator, e.g. to 1.

Speed Ref (denom); (in the Speed Measurement menu)

Here you can set the speed reference denominator, e.g. to 1.

Filter Entry

The parameter entry (filter) defines whether the frequency parameters will be freely entered via the alphanumeric keypad (*Free*) in the module setup, or whether this will occur in preset steps (*Stepwise*).

Trigger

The trigger defines how and when the reference channel signal is evaluated.

For measuring value acquisition you can select the triggering types *Automatic*, *Manual* or *Visual*.

Fixed trigger



Note!

When recording speeds below 3 Hz with the Overalls, FFT-Analyzer and Balancer modules, it is advisable to set the triggering to fixed in the system setup, as otherwise the speed cannot be reliably recorded.



Visual trigger

The visual trigger type allows you to visually display the current trigger level and trigger signal. This makes it easier to determine and set a sensible trigger threshold. The trigger level is selected with the **↑** (up) cursor key. This functionality is also available in the Balancer module.

Trig Level (in the Trigger menu)

Here you can set the trigger threshold from which triggering occurs, e.g. 2V.



Note!

The trigger threshold on the USB DEV/TRIG/PWR reference channel for reliable detection of the reference impulse should be min. 1.5V.

Ext Trig Slope (in the Trigger menu)

The trigger edge is set here: Falling edge (minus -ve), rising edge (plus + ve).

Module CCS

You can edit the global Constant Current Supply/CCS settings for connected sensors here.

The available settings are *Automatic* (sensors are supplied as required), *On* (sensors are always supplied) and *Off* (sensors are not supplied).

Date format

You can select the format for the date display subsequently used by the device here. The following can be selected:

- **DD/MM/YYYY** (Days/Months/Years)
- **MM/DD/YYYY** (Months/Days/Years)
- **YYYY/MM/DD** (Years/Months/Days)



Time zone

Define the time zone used by the device here. All time zones are stored here - simply select the right one.

Date/Time

Here you can set the date and time according to the date format for each input field. These are then displayed in the header line.

Memory Options

This setting allows you to format data carriers by means of a command and thus correct all data on the storage card or in the internal memory (depending on the setting made under the *Memory* parameter).

Keybd Backlight

Here you can activate (*On*) and deactivate (*Off*) the backlighting of the cursor keys.

Language

Here you can define the language used in all modules of the device. All available languages can be selected from a list.

7.8.2 Sensor Setup

The settings for the sensors are made in the *Sensor Setup*. You can select or define sensors for the entire system; these will be available in the modules according to the specification which you have defined.



Note!

The Brüel & Kjær Vibro GmbH sensors are already contained in the *Sensor Setup* database. Additional sensors from other manufacturers can be added here.



- ❑ Go to the *Main Mask*.
- ❑ Select *Sensor Setup* with the cursor keys.
- ❑ Press the *fire key* or the SETUP function key.

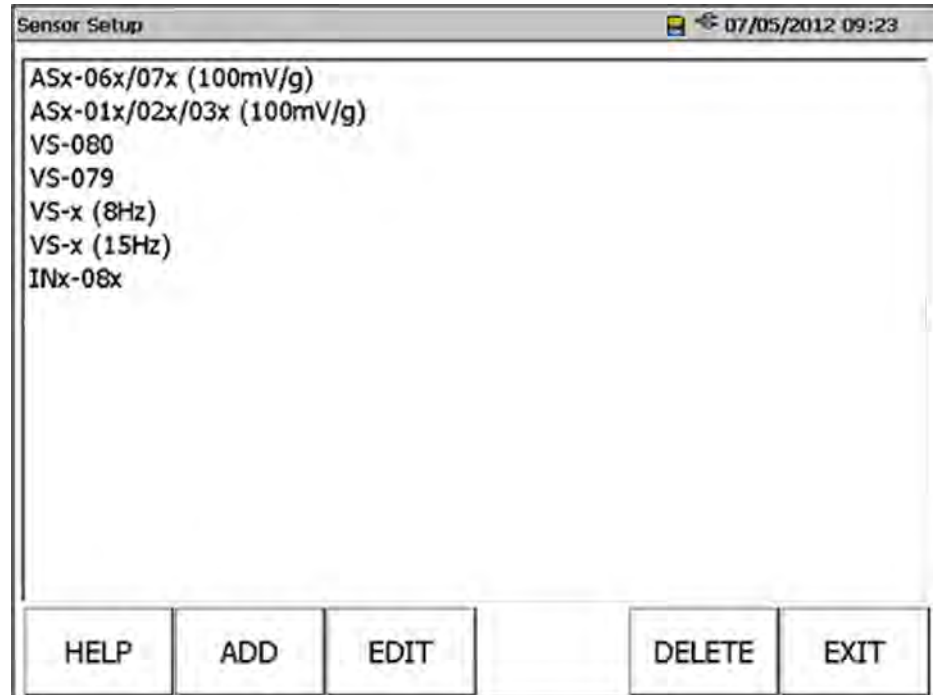

Fig. 14 Sensor Setup

All previously acquired sensors are displayed here.

NEW

The NEW softkey adds an additional sensor. A mask opens for setting the properties. The name of the sensor, the sensor units (g, mm/s, um, m/s², in/s, mil, V), the sensor sensitivity, the CCS current and the offset (mV) can be specified.

VIEW

When this softkey is activated, the selected sensor is displayed in detail.

EDIT

The EDIT softkey allows you to change the properties of the selected sensor. The same settings are available as when adding a sensor.



DELETE

The DELETE softkey permanently deletes the selected sensor from the memory of the VIBROPORT 80. A security query must be confirmed before deletion.



Note!

When deleting a sensor please note that it will no longer be available for measurements, or will have to be newly created first of all.

The sensors available on delivery of the device cannot be deleted (context-sensitive fading out of the DELETE softkey).



8 Example measurement - Overalls

The *Overalls* module allows you to analyze the overall condition of a machine and compare it to the limit values established by DIN ISO 10816 or the manufacturer's data and empirical values, for example. A single overall can provide information on the general condition of a machine, enabling a basic condition assessment to be carried out easily and efficiently. In addition to overalls for the absolute bearing vibration and the relative shaft vibration, overalls for assessing the rolling-element bearing condition (BCUp, ECUp) can also be evaluated.

Up to four measuring channels plus a speed reference are available. Each measuring channel has two digital signal processing paths A and B, allowing several measurements to be performed in parallel.

The Overalls module also supports measurement of the machine shaft speed and recording of overalls as a function of speed or time.

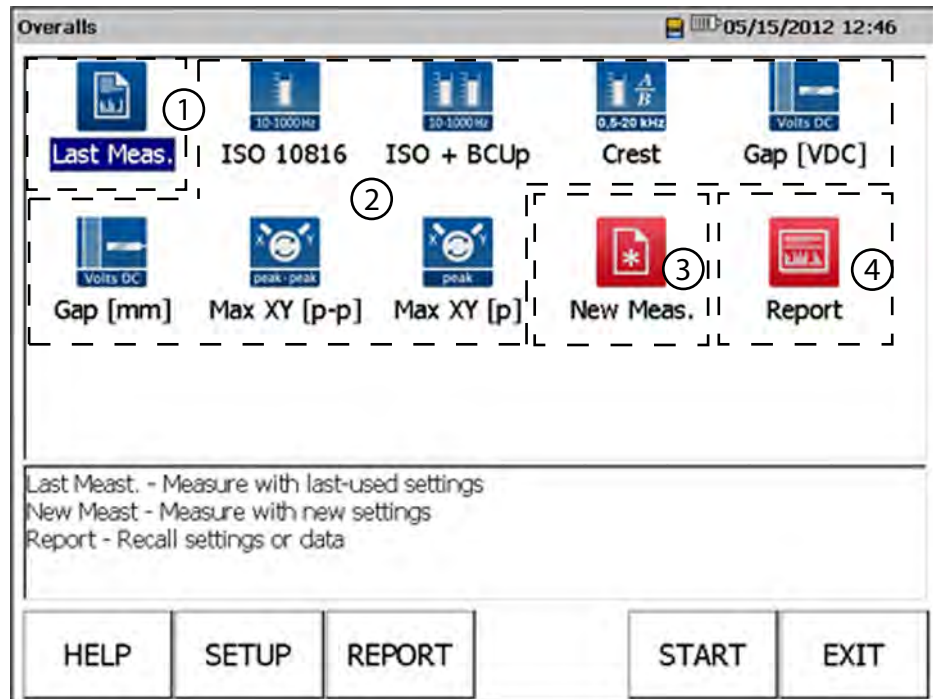

Fig. 15 Overview of overalls

- [1] Last measurement
- [2] Predefined measurement
- [3] New measurement
- [4] Report

Note!



There are several options for performing a measurement.

Last measurement

Last measurement saves the setup last used for a measurement. This automatic saving (under the *Last measurement* icon) is performed if you have called up a measuring mask with any setup (level 4). You have the following two options with *Last measurement*:

You can perform the *Last measurement* and check the *Setup* beforehand by means of the *fire key* or the **SETUP** softkey, or start the *Last measurement* directly (**START** softkey).



Predefined measurements

Here you can start the measurements (measuring tasks) predefined by Brüel & Kjær Vibro GmbH. The predefined measurements reflect frequently occurring, typical and important measuring tasks in condition monitoring. The settings for the respective measurement are already predefined and cannot be deleted by the user. However, the settings of the predefined setups can be adapted for an individual measurement. When a predefined measurement is next called up, it is reset to the default setting.

Alternatively, it is possible to save self-defined setups as a file and load them with the *Report* function.

You cannot create new (self) predefined measurements.

New measurement

You can define a new setup for a measurement by selecting New measurement and pressing the *fire* key. When the *Setup* has been edited, the new measurement is started with the START softkey or the *fire* key.

Report

You can call up the *Report* mask with the REPORT softkey or the *fire* key (the REPORT icon must be selected /highlighted). In the Report mask you can back up (BACKUP), delete (DELETE) or open and execute (OPEN) the saved setups and measurements.

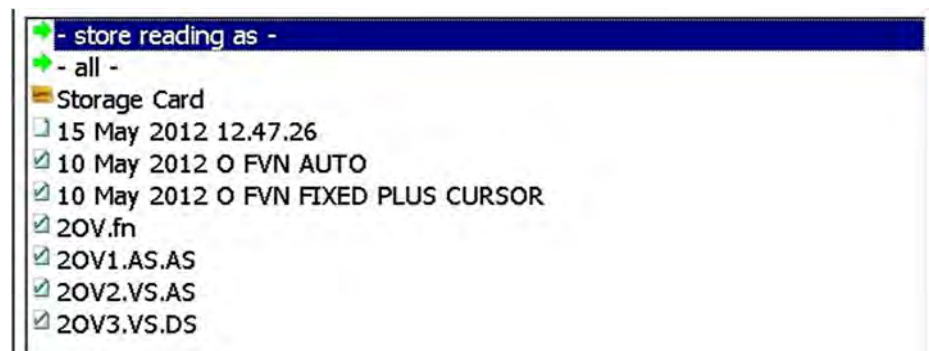

Fig. 16 Setup of the last measurement



You will find setups (identified by a sheet as icon) and measurements (identified by a sheet with a tick as icon) listed here.

8.1 Start of example measurement

The *Overalls* module is used for the example measurement here. In principle all module masks / overviews are very similar and are operated according to the same logic.

The procedures and settings described below can therefore be transferred to the other modules.

Proceed as follows:

- Start the VIBROPORT 80 with the *On/Off* key.
- ⇒ The device starts.
- ⇒ The *main mask* appears.



Note!

If you have not yet correctly connected the necessary sensors to the VIBROPORT 80, do this now.

-
- Select the *Overalls* module with the cursor keys.
 - Press the *fire* key.
 - ⇒ The *Overalls* mask opens.

8.2 Perform new measurement

You can perform a new measurement here. Before starting a setup mask will be displayed, in which you can set up the new measurement.

- Select *New measurement* with the cursor keys.
- Press the *fire* key.
- Edit the *Setup* if necessary.
- Press the START softkey.



Note!

The STOP and STORE softkeys allow you to save the current measurement in the *Report* and reuse it.

-
- Perform the new measurement.
 - End the new measurement with the EXIT softkey.



8.3 Perform predefined measurement

Predefined measurements are specifically designed for frequently occurring measuring tasks. Therefore these measuring tasks do not have to be specially created and saved.

Predefined measuring tasks can be started directly (START softkey) or configured (*fire key*) or SETUP softkey before starting the measurement.

The settings of the setup can be individually configured, but will always be reset to the respective default setting when the setup is next used.

- Select the predefined measurement with the cursor keys.
- Press the START softkey (directly to measurement) or the *fire key* or the SETUP softkey.
- Edit the *Setup* if necessary.
- Press the START softkey.

Note!



The STOP and STORE softkeys allow you to save the current measurement as a report and reuse it.

-
- Perform the predefined measurement.
End the predefined measurement with the EXIT softkey.

8.4 Perform last measurement and check setup

If you wish to call up and check the settings of the *Last measurement* (or a predefined measurement) before you perform this measurement, proceed as follows:

- ❑ Press the *fire key* (or the *SETUP* softkey).
- ⇒ The *Overalls setup* mask opens.

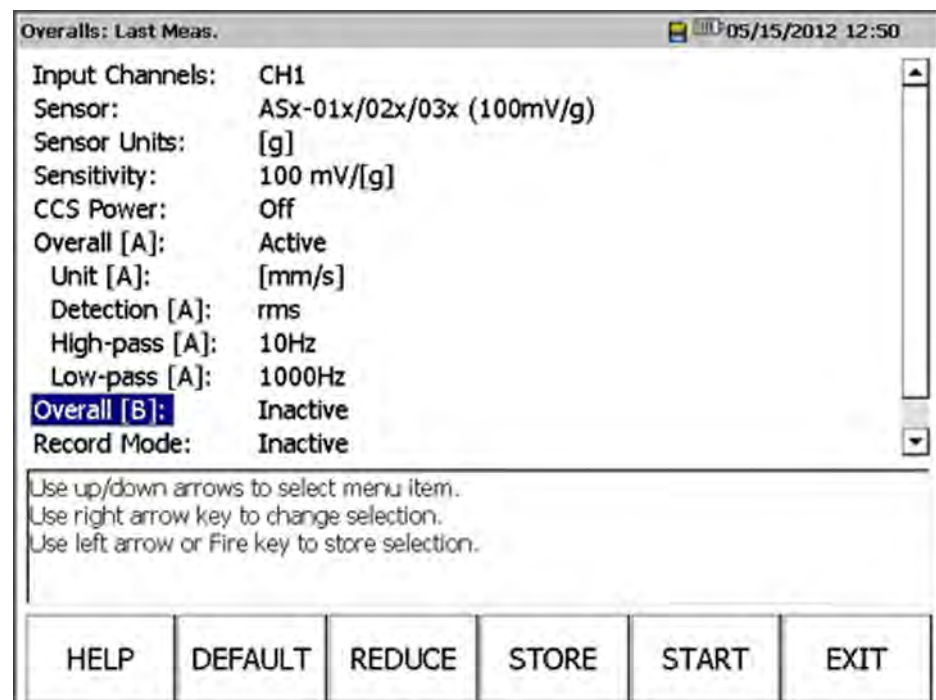

Fig. 17 Setup of the last measurement

Note!



The EXPAND softkey displays all setting options for the setup. The REDUCE softkey only displays the basic setting options, which are adequate for most applications.

- ❑ Check the connected sensors in the *Setup of the Overalls*.
- ❑ Edit the *Setup* settings if necessary.
- ❑ Save them with the STORE softkey, if you wish to reuse the edited settings at a later point in time.
- ❑ Start the measurement with the START softkey or the *fire key*.
- ⇒ The measurement starts.

8.5 Directly start last measurement

If you wish to repeat the *Last measurement* carried out, proceed as follows:

- ❑ Press the START softkey.
- ⇒ The *Overalls data* mask opens and the measurement starts directly (indicated by softkey F5 which displays STOP = Measurement running).

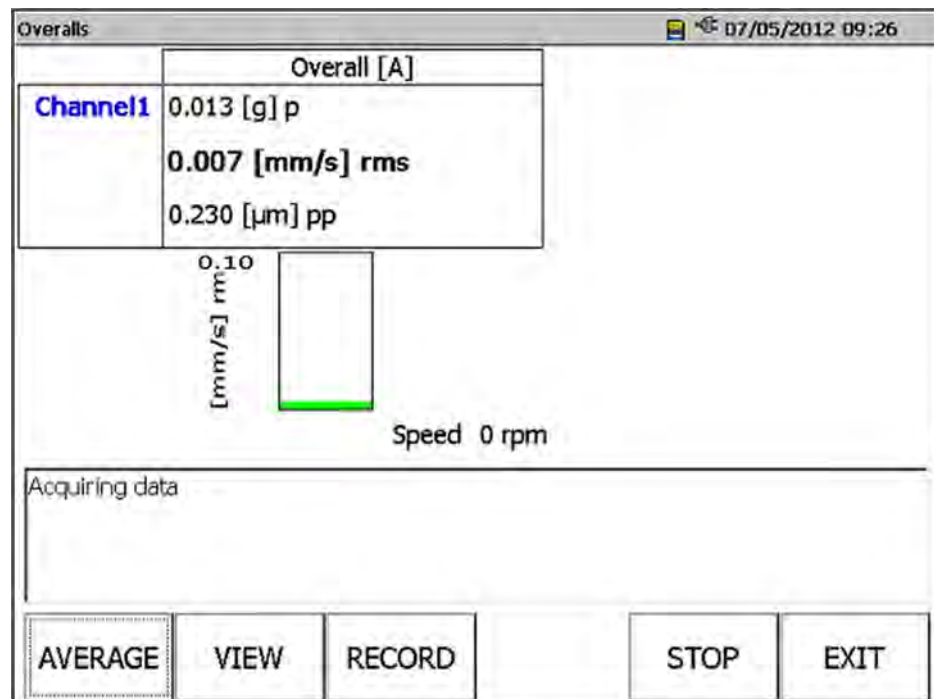

Fig. 18 Measurement of overalls

In this example a single-channel measurement, with overall only in path A, is displayed in both a table and as a bar chart - the main value selected in the setup was [mm/s] rms (see previous page).



Note!

The softkeys provide different functions during the measurement.



During execution of the measurement you can:

- Call up an average determination to stabilize the measuring values (AVERAGE).
- Change the representation (VIEW).
- Record the data over speed $f(n)$ or time $f(t)$ (RECORD), if you have previously defined this in the setup.
- Pause and continue the measurement (PAUSE/CONT.).
- Start / stop the measurement (START / STOP).
- And exit the mask (EXIT).

If you have pressed STOP, you can save the measuring data (STORE).

After exiting the mask you return to the *Overalls* mask.

8.6 Change display / representation during measurement

The *Overalls* module and the other modules have different options for displaying the measuring results.



You can select individual representations (tabular view) or combine different representations (tabular view + bar graph).

- Start the measurement with the START softkey.
- Press the VIEW softkey.
- The following mask opens:

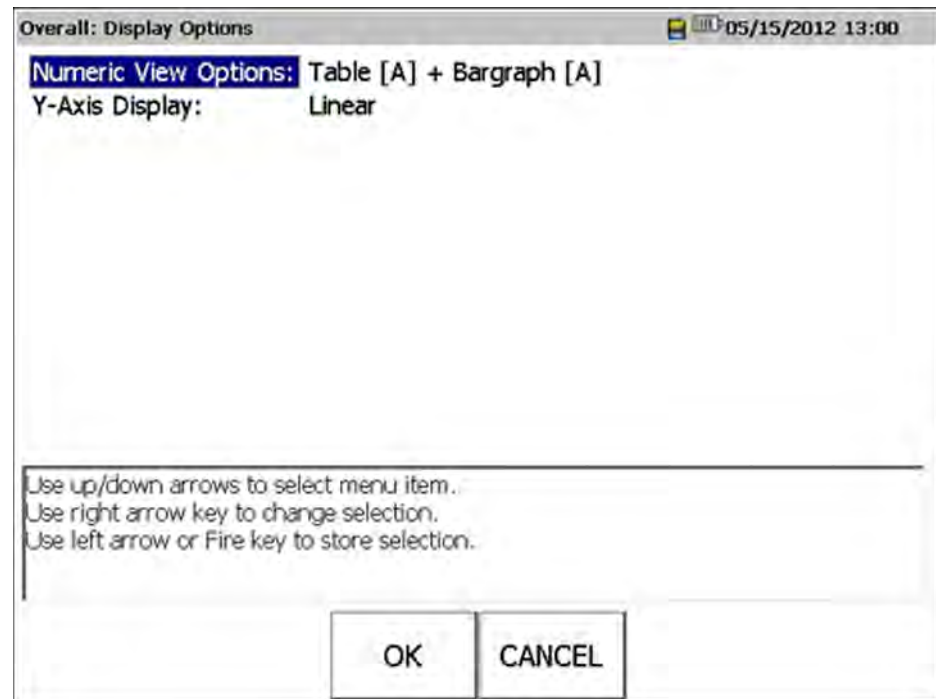

Fig. 19 Display options

- Select the desired parameter with the cursor keys, edit it and press the *fire key*.
- Press the OK soft key.
- ⇒ The measurement continues running and is shown with the new display / representation.

8.7 End current measurement

When ending a running measurement a standard query dialog appears in all modules. This specifies different procedures.

- Go to the measurement.
- Press the EXIT softkey.



STORE

When you press this softkey the current measurement is saved as a report and can be called up again later.

EXIT

The measurement is rejected, not saved and you are returned to the *Overalls* mask.

CANCEL

You are taken back to the last measurement. The last measuring data can then be displayed.

8.8 Save measurement

You have the option of saving measurements. This means that you can call up measurements which you have adapted in the module setup and in the measurement overview at any time. In addition to the measuring result, the setup which is linked to the measurement is also saved.

- End the measurement with the STOP softkey.
- Press the STORE softkey.
- ⇒ The following mask opens:

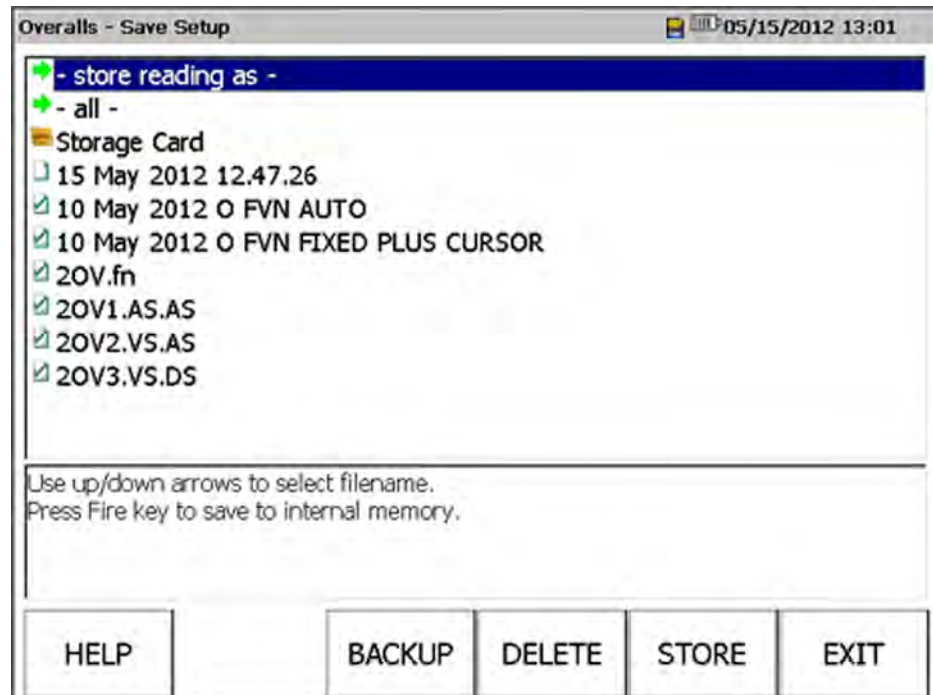

Fig. 20 Report overview

- ❑ Allocate a new name for the measurement, using the alphanumeric keypad or accept the name suggested by the VP-80 (Name: Date / Time).
- ❑ Press the OK softkey.
- ⇒ The measurement is saved.



8.9 Load and execute saved measurement (open report)

Either load saved measurements, so that you can reuse their setup for another measuring task, or directly use one of the setups stored here for your next measurement. The REPORT mask will assist you.

- ❑ Press the REPORT softkey.
- ⇒ The following mask opens:

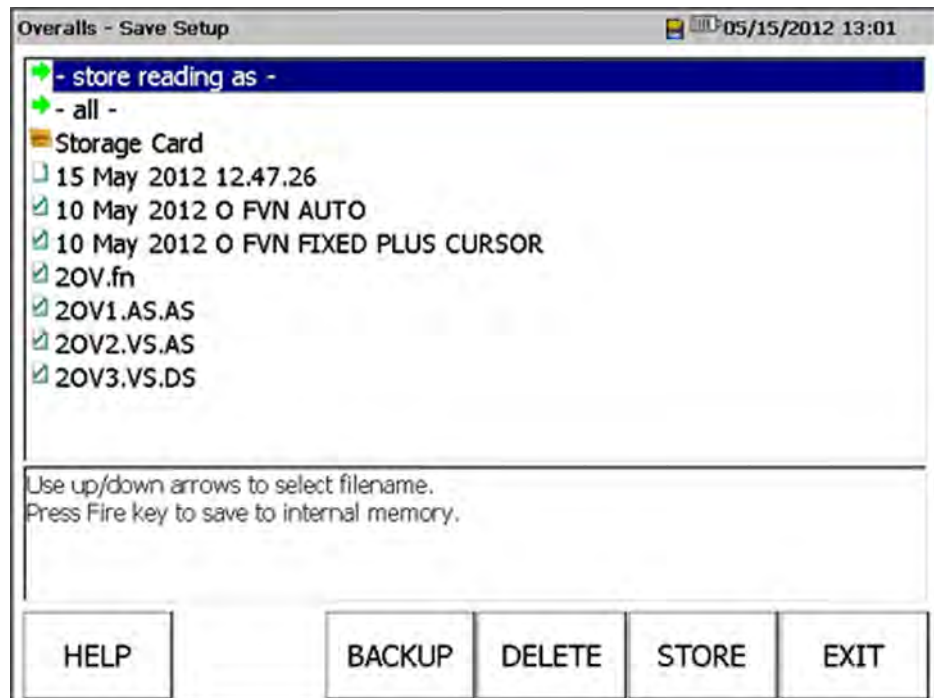

Fig. 21 Report overview

- ❑ Select the desired measurement with the cursor keys.
- ❑ Press the SELECT softkey.
- ⇒ The measurement is opened.
- ❑ Press the START softkey.
- ⇒ The loaded measurement is performed.



9 Setup Parameters for the Measuring Modules

9.1 General

The following tables will help you to understand and set the options and setup parameters for the individual modules.

A setting option and an explanation are provided for each parameter. The setup parameters are called up in the modules with the SETUP softkey or with the *fire key*.



Note!

The settings described in the following are also based on the *System Setup* and the *Sensor Setup*.



Note!

Parameters which can be seen as standard are shown in bold in the table. The EXPAND function key has not yet been activated here.

All other parameters are listed directly afterwards. These depend on the specific setting.

The EXPAND function key has already been activated here.

9.2 Important notes on the modules

9.2.1 Vibration acceleration and vibration displacement measurements

In the case of an acceleration measurement and subsequent single integration of the measuring signal for vibration velocity or double integration for vibration displacement, the signal to noise ratio must be noted if parameter settings are selected in the setup with high-pass filter limit frequencies below 10 Hz. In these cases, the background noise of the device together with the noise components of the measuring chain can e.g. result in vibration displacements, which are in an order of magnitude of roughly 50 to 100 μm or more. Moreover, this behavior occurs increasingly the lower the high-pass filter limit frequency selected. In order to obtain reliable measuring values, an adequately high signal to noise ratio should be provided for the application.



The following table indicates the order of magnitude of the noise values depending on the high-pass filter frequency (HPF). The designations in the top row refer to single or double integration including signal detection.

HPF Hz	mm/s rms	mm/s p	mm/s pp	µm rms	µm p	µm pp
0.18	2	3	5	800	1000	1200
0.36	1	2.5	5	500	500	1000
1	0.5	2	4	150	300	400
2	0.5	1.5	3	100	150	200
3	0.5	1.5	3	50	50	100

9.2.2 FFT-Analyzer module

The overalls displayed in the Analyzer are based on a recalculated spectrum and do not claim to have the specified accuracies. Please use the Overalls module for a precise measurement of the overalls.

9.2.3 Balancer module

For correct calculation of the angle for correction weights it is important to note, to count against the rotational direction of the rotor (shaft). Looking on the rotating shaft (cross section) with rotational direction clockwise, the Components 1, 2,3 and so on are counted counterclockwise.

Note!



It is recommended not to stop the current (don't stop the machine) until the Vibration Levels measurement (Amplitude and Phase) are relatively stable and settled. It is useful, by experience, to activate the averaging by the AVERAGE function key."



9.2.4 Time Signal module

Display

The Time Signal module is based on a special procedure during measurement. In a first step, a live preview of the existing time signal including offset is displayed. When you have started the measurement the signal display is “frozen”, but the actual measurement continues in the background until you end the measurement.

Trigger level

When defining the trigger level in relation to the measuring signal level please note that the amplitude of the measuring signal is not used as trigger threshold, but the calculated total vibration overall (shown in the top right of the display.)

9.2.5 Tracking

The start and stop speeds result from an average value formation from the recorded time data blocks. This can mean that the scaling of the X-axis does not correspond to the start and stop speeds specified in the setup.

In the Tracking Module the detection of the Triggerpoint is always based on the positive (increasing) Trigger slope +ve of the Triggersignal. The corresponding Parameter setting in the System Setup is ignored.

After post processing of the measured time signal the phasing at the beginning of the phase course is not defined clearly. It depends on the Start speed of a measurement as well as on the specified Precision (Sampling Rate) in the measurement setup. However the relative phase course of the measurement is determined correctly in regards to the mechanical properties of underlying system application. Finally it is the relative phase course which allows for the identification of a present resonance.



9.3 Overalls

Parameter	Setting parameter	Explanation of the parameter
Input channels	CH1(&CH2&CH3&CH4)	Definition of the number of input channels.
Sensor	B&K Vibro sensors; Process; Variable	Sensor type
<u>Selection in "Sensor"</u>	B&K Vibro sensors e.g. ASx-06x/...	N/A
Sensor units	e.g. g	Sensor unit
Sensitivity	e.g. 100 (mV/ <i>Sensor Units</i>)	Sensitivity per sensor unit.
CCS Power	On; Off	Constant Current Supply. Depending on selection in "Sensor".
<u>Variable</u>	Variable	N/A
Sensor Units	N/A	See above
Sensitivity	N/A	See above
CCS Power	N/A	See above
<u>Process</u>	Process	N/A
Sensor Units	N/A	See above
Sensitivity	N/A	See above
Offset	N/A (mV)	Sensor offset: The offset is calculated according to the following formula: Signal_Off = Signal-offset



Parameter	Setting parameter	Explanation of the parameter
Input range	Automatic Scaling; Maximum; Sensor Units	Depending on the setting in the System Setup, only appears if <i>Sensor Units</i> has been selected. Automatic Scaling should be set by default.
Overall [A]	Active	Status of path A for overall measurement.
Unit [A]	g; m/s ² ; mm/s; μm	Display unit for path A
Detection [A]	rms; p; pp; pc; ppc; CREST [A]/[B]	Signal detection of overall for path A.
High-pass [A]	e.g. 10 Hz	High-pass limit frequency for path A (range depends on input channel setting).
Low-pass [A]	e.g. 1000 Hz	Low-pass limit frequency for path A (range depends on input channel setting).
Overall [B]	Active; Inactive	Status of path B for overall measurement.
Unit [B]	g; m/s ² ; mm/s; μm; ECU _p ; BCUp	Display unit for path B (range depends on input channel and sensor settings as well as interaction with path A).
Detection [B]	rms; p; pp; pc; ppc	Signal detection of overall for path B.



Parameter	Setting parameter	Explanation of the parameter
High-pass [B]	e.g. 10 Hz	High-pass limit frequency for path B (range depends on input channel setting).
Low-pass [B]	e.g. 1000 Hz	Low-pass limit frequency for path B (range depends on input channel setting).
Max X/Y	On; Off	Acquisition Max X/Y. (Depends on input channels).
Record Mode	Inactive; f(n); f(t)	Activation of overalls versus speed f(n) or time f(t).
Record Mode > active f(n)	N/A	
Direction	Coastdown; Runup; Manual	Change in machine condition
Minimal Speed	e.g. 600 rpm	Definition of data acquisition from/to speed...
Maximal Speed	e.g. 1500 rpm	Definition of data acquisition from/to speed...
Record Mode > active f(t)	N/A	
Time Unit	sec; min; hours	Time unit for the measurement.
Record Time	e.g. 5 min	Recording period.
Time Interval	e.g. 1 sec	Time interval of data recording.

Tab. 9 Overalls setup parameters



9.4 FFT-Analyzer

Parameter	Setting parameter	Explanation of parameter
Input Channels	CH1(&CH2&CH3&CH4)	Definition of the number of input channels.
Sensor	B&K Vibro sensors; Variable	Sensor type
Sensor Units	e.g. g	Sensor unit
Sensitivity	e.g. 100 (mV/ <i>Sensor Units</i>)	Sensitivity per sensor unit.
CCS Power	On; Off	Constant Current Supply. Depends on selection in Sensor.
Display Format	Spectrum; Time; Spectrum+Time ; Spectrum+Phase; Spectrum+Cross Phase; Orbit	Analysis which is displayed during the measurement. Spectrum+Cross Phase and Orbit are available for precisely 2 input channels.
Units	g; m/s ² ; mm/s ; μm; Envelope SED; Envelope BCS	Display unit. Up to two input channels are also available for envelope spectra SED and BCS with the relevant units ECU and BCU.
SED Band	e.g. 1 to 10 kHz	Only appears if an envelope spectrum has been selected under <i>Units</i> .
Frequency Type	Hz; CPM; Orders	The inscription or unit for the X-axis.



Parameter	Setting parameter	Explanation of parameter
High-Pass	e.g. 10 Hz	High-pass limit frequency (range depends on input channel setting).
Low-Pass	e.g. 1000 Hz	Low-pass limit frequency (range depends on input channel setting).
Low-Pass FFT	e.g. 1000 Hz	Depends on whether SED or BCS has been selected under Unit.
Y-axis	Linear; Logarithmic; dB	Scaling of Y-axis.
Input Range	Automatic Scaling; Maximum; Sensor Units	Depends on setting in System Setup, only appears if <i>Sensor Units</i> has been selected. Automatic Scaling should be set by default.
dB Reference	Any	Reference value for location of dB range of Y-axis. Depends on setting in Y-axis.
dB Ref Units	μm ; $10^3 \mu\text{m}$; $10^6 \mu\text{m}$	Scaling of dB range of Y-axis. Depends on setting in Y-axis.
Detection	rms; p; pp; pc; ppc	Signal detection.
Lines	100 to 25,600	Line resolution of FFT.



Parameter	Setting parameter	Explanation of parameter
Avg. Type	rms; Exponential; PeakHold; Time-synchronous	Type of averaging (depends on speed activation in System Setup).
Num. Averages	1 to 255	Number of averages.
Overlap	0 % to 99 %	Overlap when editing or calculating the FFT. It is expedient to increase the overlap at lower frequencies, but as the overlap increases the similarity of the information contained in the calculated FFT averages also increases. As a guide value an overlap of 50 % is advantageous below 2 kHz.
Window	Hanning; Hamming; FlatTop; Uniform	Windowing or window type for the FFT.

Tab. 10 FFT-Analyzer setup parameters



9.5 Balancer

Parameter	Setting parameter	Explanation of parameter
Plane Setup	Single plane (A=CH1); Two plane (A=CH1 & B=CH2); Two plane (A&B=CH1)	Selection of planes for balancing. Two-plane balancing can also be performed sequentially with a sensor.
Sensor	B&K Vibro sensors; Variable	Sensor type
Sensor Units	e.g. g	Sensor unit
Sensitivity	e.g. 100 (mV/ <i>Sensor Units</i>)	Sensitivity per sensor unit.
CCS Power	On; Off	Constant Current Supply. Depends on selection in <i>Sensor</i> .
Units	g; m/s ² ; mm/s ; μm	Display unit
Detection	rms; pc; ppc	Signal detection.
Weight Units	g; kg; %	Units of weights applied or removed.
Length Units	mm; cm; m; EU	Units of length
Trigger	Automatic; Manual; Visual (the trigger level can be visually displayed and helps you determine a trigger threshold)	Type of triggering
Trigger Slope	-ve; +ve	Trigger slope - falling edge (minus) rising edge (plus).



Parameter	Setting parameter	Explanation of parameter
Trigger Level	e.g. 2 V	Trigger level from which triggering occurs.
Vib. Threshold	e.g. 8 mm/s	A vibration reference limit which is displayed in the bar graph and in the polar plots. If the value is exceeded, the bar graphs or vector arrows are displayed in red.
Solution	Standard; 1-2 Plane with Prognosis	Standard balancing solution or 1-2 plane with prognosis, allowing two balancing problems to be solved:
A)	<p>1-plane balancing with measurement at both bearings!</p> <p>In this balancing process the correction weight of plane A is calculated after the initial run and trial run A. The residual vibration of plane 1 and plane 2 is predicted by the VIBROPORT 80.</p>	
B)	<p>2-plane balancing with prognosis!</p> <p>In this balancing process the correction weight of plane A is calculated after the initial run and trial run A. The residual vibration of plane 1 and plane 2 is predicted by the VIBROPORT 80. If the predicted residual vibration is adequate, trial run B can be omitted.</p> <p>If the predicted residual vibration is inadequate, the balancing process can be continued with trial run B.</p>	



Parameter	Setting parameter	Explanation of parameter
Correction type	Polar correction; Fixed location; Fixed weight	
A)	Polar correction With polar correction the weight and its application point are freely selectable.	
B)	Component correction With component correction 3 - 99 fixed locations can be selected (e.g. fan vanes, equidistant holes on rotor circumference). The test weights are mounted in a fixed location for the trial run. VIBROPORT 80 calculates the correction weights for two (adjacent) component locations.	
C)	Fixed weight correction With fixed weight correction the weight is preselected. The fixed weight is mounted in any location for the trial run. The VIBROPORT 80 calculates the two locations of the identically fixed correction weights.	
Num Components	e.g. 5	Depends on whether Component has been selected under Correction Type.
Fixed Weight	e.g. 100 g	Depends on whether Fixed Weight has been selected under Correction Type.

Tab. 11 Balancer setup parameters



9.6 Tracking

Parameter	Setting parameter	Explanation of parameter
Input Channels	CH1 (&CH2&CH3)	Definition of the number of input channels.
Sensor	B&K Vibro sensors; Variable	Sensor type
Sensor Units	e.g. g	Sensor unit
Sensitivity	e.g. 100 (mV/ <i>Sensor Units</i>)	Sensitivity per sensor unit.
CCS Supply	On; Off	Constant Current Supply. Depends on selection in <i>Sensor</i> .
Input Range	e.g. 1g	Measuring range of input signal. Depends on selection in <i>Sensor</i> .
Precision	Low (faster processing); Normal; High (slower processing); Very high (slow processing)	Precision and resolution of the recorded measuring data. Either a low resolution can be selected (Low), which means that post-processing will be very quick. Or a high resolution (Very high) can be selected, with the result that post-processing will take longer. The sampling frequency is directly determined by means of the different resolutions.



Parameter	Setting parameter	Explanation of parameter
Record Mode	Coastdown; Runup; Manual	You can select whether the system has a runup or a coastdown. Manual records data independently of speed, and can be used if no speed signal is available.
Pulses/Rev	1 to 1000	Defines the number of pulses per revolution expected by the speed output. For example, 4 must be set if 4 reflex marks (e.g.: at a distance of 90°) are applied to the rotor.
Start Speed(RPM)	e.g. 600 rpm	Definition of data acquisition speed...
Stop Speed(RPM)	e.g. 1500 rpm	Definition of data acquisition speed...
Save To	Internal or SD storage card	Selection of storage location for the measuring data. It is advisable to specify the SD storage card here, as the *.wav files recorded in the Tracking module have a large file size/data volume. The following parameter <i>Max Acq Time (sec)</i> is adapted to assist the user, depending on which storage medium is selected.



Parameter	Setting parameter	Explanation of parameter
Max. Acq Time (s)	Any	Defines the maximum permissible time for data acquisition in seconds. Is adapted depending on the storage medium selected, so that the maximum possible recording time is displayed. This decreases, the more memory is already occupied.

Tab. 12 Tracking setup parameters



9.6.1 Tracking - signal processing setup

Parameter	Setting parameter	Explanation of parameter
Channels	CH1; CH2; CH3	Channel used for calculation.
Start Speed(RPM)	e.g. 600 rpm	Definition of data acquisition speed...
Stop Speed(RPM)	e.g. 1.500 rpm	Definition of data acquisition speed...
Spacing	e.g. Δ rpm	Type of delta or interval of the X-axis.
Speed Interval (RPM)	e.g. 10	Value of speed interval
Time Interval (s)	e.g. 1	Value of time interval
Display Units	e.g. g	Display unit after calculation, which performs an integration during the calculation if required.
LF Cutoff	On; Off	Filter for filtering low-frequency interference.
Detection	rms; pc; ppc	Signal detection or detection of overall.
Y-axis	Linear; Logarithmic	Scaling of Y-axis
Show Overall	On; Off	In addition to the displayed orders, a total vibration overall can be displayed.
Num Traces	1; 2; 3 (4)	Number of orders to be calculated.
Order #1 (#2,#3,#4)	e.g. 4	Orders which are calculated.

Tab. 13 Setup parameters for tracking before calculation



9.7 Transfer Function

Parameter	Setting parameter	Explanation of parameter
Input Channel	CH1 (&CH2&CH3)	Definition of the number of input channels.
Excitation Mode	Hammer; Continuous	Hammer is set for measuring the transfer function. Continuous for ODS analysis - instructions can be found in the manual for the ODS software used.
Sensor	B&K Vibro sensors; Variable	Sensor type
Sensor Units	e.g. g	Sensor unit
Sensitivity	e.g. 100 (mV/ <i>Sensor Units</i>)	Sensitivity per sensor unit.
CCS Power	On; Off	Constant Current Supply. Depends on selection in <i>Sensor</i> .
Res. Input Range	Automatic; <i>Sensor Units</i> , e.g. 10 g.	Input range of the sensor used (for the pulse response). If this parameter is set to <i>Automatic</i> , the user is prompted to enter three hammer hits to enable automatic determination of the range.
Hammer Units	N; lbf	Units of impact hammer in metric or imperial.



Parameter	Setting parameter	Explanation of parameter
H. Sens.	e.g. 2	Sensitivity per hammer unit (mV/ <i>Hammer Unit</i>).
H. CCS Power	On; Off	Constant Current Supply for impact hammer.
Measurement	Compliance; Stiffness; Mobility; Impedance; Accelerance; Apparent Mass	Defines the type of transfer function and the display type. Depending on <i>Sensor</i> all transfer function types are displayed for acceleration sensors, as 4 types can be determined by means of signal integration if necessary. For speed sensors (VS) 4 types are displayed, as 2 can be determined by means of signal integration if necessary. For displacement sensors only two are displayed (stiffness and compliance).
Meas Units	N/ μ m; μ m/N ; N/mm/s ; mm/s/N ; N/m/s ² ; m/s ² /N	Defined depending on the <i>Measurement</i> parameter.
Y-axis	Linear; Logarithmic; dB	Scaling of Y-axis
Hammer Range	Automatic; <i>Hammer Units</i> , e.g. 10 N	Measuring range of hammer signal. Depending on selection in <i>Hammer Units</i> .



Parameter	Setting parameter	Explanation of parameter
Low Pass	1 to 20,000 Hz	Frequency range of the determined transfer function. The recording time changes accordingly in the status window.
Lines	Automatic; 100 to 6400	Resolution of the transfer function.
Window	Exponential; Uniform	Window type for the pulse response FFT.
Num. of Averages	1 to 255	Number of averages. This is the number of hits that must be given with the impact hammer.
Accept/Reject	Manual; Automatic	You can specify whether measurements are accepted or rejected manually or automatically. In the case of <i>Automatic</i> the measurement is rejected e.g. following a double-bounce hit.
Invert Phase	On; Off	Application of a 180° phase offset in the determined transfer function. This option is recommended if an inversion is desired at a corresponding position of the hammer hit or measuring position of the sensor.



Parameter	Setting parameter	Explanation of parameter
Good Coherence	1 % to 100 %	Setting of the threshold value at which the transfer function is displayed red (poor coherence) or green (good coherence) according to the percentage value. The coherence is a measure of how linearly or interference-free the hammer pulse is converted into the pulse response.
Save To	Internal or SD storage card	Selection of storage location for the measuring data.
Posn. Auto-incr	On; Off	Enables automatic file name allocation when saving measuring data 0001.csv, 0002.csv, etc.
Start Index *.csv	1,2,3, etc.	Start index number at which file name allocation is started.

Tab. 14 Transfer function setup parameters



9.8 Time Signal

Parameter	Setting parameter	Explanation of parameter
Input Channels	CH1 to CH4 or CH1 to CH3 with speed sensor.	Definition of the number of input channels including / excluding speed sensor.
Sensor	B&K Vibro sensors; Variable	Sensor type
Sensor Units	e.g. g	Sensor Unit
Sensitivity	e.g. 100 (mV/ <i>Sensor Units</i>)	Sensitivity per sensor unit.
CCS Power	On; Off	Constant Current Supply. Depends on selection in <i>Sensor</i> .
Input Range	e.g. 1g	Measuring range of input signal. Depends on selection in <i>Sensor</i> .
Low-Pass	1 to 20,000 Hz	Low-pass limit frequency for filtering the recorded time signal.
Save To	Internal or SD storage card.	Selection of storage location for the measuring data. It is advisable to specify the SD storage card here, as the *.wav files recorded in the Tracking module have a large file size/data volume.
Rec. Time (s)	Any	Defines the recording time of the data acquisition.



Parameter	Setting parameter	Explanation of parameter
Rec. Mode	Manual; CH1 Level ; Tacho	Defines whether data recording will be triggered manually or by a trigger threshold value. This trigger can be provided by the speed signal (Tacho) or a CH1 level.
Trig. Level	e.g. 1 g	Depending on <i>Sensor Units</i> and <i>Record Mode</i> .

Tab. 15 Time signal setup parameters



10 Recycling / Disposal

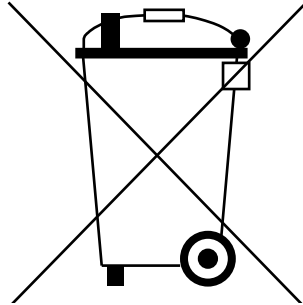

The defective / unusable AC-7003 battery must be correctly disposed of. There are special collection points for batteries. Batteries must not be disposed of as domestic waste, but as special waste!

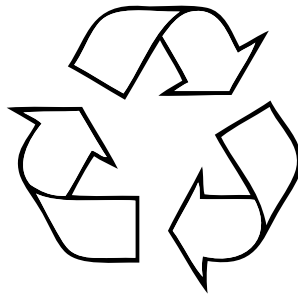

Observe the local regulations. In Germany, battery recycling is regulated by the Batteries Act.



Note!

If the VP-80 is not used for longer than a week, it must be removed from the mains-connected docking station.

The VP-80 must be stored in a suitable temperature range.



11 CE Declaration of Conformity



Brüel & Kjær Vibro

*EG-Konformitäts-Erklärung
EC Declaration of conformity*

Hiermit bescheinigt das Unternehmen / *The company*

Brüel & Kjær Vibro GmbH
Leydheckerstraße 10
D-64293 Darmstadt



die Konformität des Produkts / *herewith declares conformity of the product*

Datensammler / Data Collector

Typ / Type

VIBROPORT 80 (VP-80), VIBROPORT 80 E (VP-80 E)

mit folgenden einschlägigen Bestimmungen / *with applicable regulations below*
EG-Richtlinie / EC directive

2004/108/EG EMV-Richtlinie / EMC Directive

94/9/EG ATEX-Richtlinie / ATEX Directive (*nur für /only for VIBROPORT 80 E*)

Angewendete harmonisierte Normen / *Harmonized standards applied*

EN 60079-0:2009 (*nur für / only for VIBROPORT 80 E*)

EN 60079-11:2007 (*nur für / only for VIBROPORT 80 E*)

EG-Baumusterprüfung / *EC-Type-Examination Certificate*

TRAC10ATEX31265X

Bereich / *Division*
Brüel & Kjær Vibro GmbH

Unterschrift / *Signature*
CE-Beauftragter

Ort/Place **Darmstadt**
Datum / Date **30.03.2012**

(N. Karg)

Fig. 22 CE Declaration of Conformity

We guarantee that the accessories and products included in the scope of supply of the VP-80 have been tested by means of all necessary tests and fulfil all CE and EMC requirements.



12 Supplier's Declaration of Conformity



Brüel & Kjær Vibro

Supplier's Declaration of Conformity



For compliance levels 1, 2 and 3 in Australia

As required by the *Radiocommunications Labelling (Electromagnetic Compatibility) Notice 2008* made under section 182 of the Australian *Radiocommunications Act 1992*

Supplier's detail	
Manufacturer Name:	Brüel & Kjær Vibro GmbH
Manufacturer Address:	Leydheckerstraße 10 D-64293 Darmstadt
Importer Name:	Spectris Australia Pty Ltd.
Importer Address:	Suite 2, 6-10 Talavera Road North Ryde, NSW. 2113
ACMA Supplier code number:	N1618

Product:	VIBROPORT 80 / VIBROPORT 80 E Vibration measuring equipment Type Balancer Select Balancer Advanced Balancer Premium Analyzer Select Analyzer Advanced Analyzer Premium
----------	---

Brüel & Kjær Vibro declares that the above mentioned product complies with the relevant ACMA standards referenced in the Radiocommunications Labelling (Electromagnetic Compatibility) Notice 2008 made under section 182 of the Australian Radiocommunications Act 1992

This product has been tested to the following standard:

Standards	Description
EN 61326-1:2006	Electrical equipment for measurement, control and laboratory use - EMC requirements

I hereby declare that the contents of this form are true and correct, that the product mentioned above complies with the relevant above mentioned standards and all products supplied under this declaration will be identical to the product identified above.

Brüel & Kjær Vibro GmbH

Signature

Place: Darmstadt
Date: 08.02.2012
Position: Quality Manager

(Adolf Siegl)





Brüel & Kjær Vibro

10/2012 - C104674.002 - V02

Brüel & Kjaer Vibro GmbH
Leydhecker Str. 10

64293 Darmstadt

Phone: +49 (0) 6151 428 11 00

Fax: +49 (0) 6151 428 12 00

E-Mail: info@bkvibro.com

© Brüel & Kjaer Vibro GmbH