

SINEAX DME 440 with RS 485 interface

Programmable multi-transducer

for the measurement of electrical variables in heavy-current power system



Application

SINEAX DME 440 (Fig. 1) is a programmable transducer with a **RS 485 bus interface (MODBUS®)**. It supervises several variables of an electrical power system **simultaneously** and generates 4 proportional analogue output signals.

The **RS 485** interface enables the user to determine the number of variables to be supervised (up to the maximum available). The levels of all internal counters that have been configured (max. 4) can also be viewed. Provision is made for programming the SINEAX DME 440 via the bus. A standard EIA 485 interface can be used, but there is no dummy load resistor for the bus.

The transducers are also equipped with an **RS 232** serial interface to which a PC with the corresponding software can be connected for programming or accessing and executing useful ancillary functions. This interface is needed for bus operation to configure the device address, the Baud rate and possibly increasing the telegram waiting time (if the master is too slow) defined in the MODBUS® protocol.

The usual methods of connection, the types of measured variables, their ratings, the transfer characteristic for each output and the type of internal energy metering are the main parameters that can be programmed.

The ancillary functions include a power system check, provision for displaying the measured variable on a PC monitor, the simulation of the outputs for test purposes and a facility for printing name-plates.

The transducer fulfils all the essential requirements and regulations concerning electromagnetic compatibility (**EMC**) and **safety** (IEC 1010 resp. EN 61 010). It was developed and is manufactured and tested in strict accordance with the **quality assurance standard** ISO 9001.

Features / Benefits

- **Simultaneous measurement of several variables of a heavy-current power system / Full supervision of an asymmetrically loaded four-wire power system, rated current 1 to 6 A, rated voltage 57 to 400 V (phase-to-neutral) or 100 to 693 V (phase-to-phase)**

Measured variables	Output	Types
Current, voltage (rms), active/reactive/apparent power $\cos\phi$, $\sin\phi$, power factor RMS value of the current with wire setting range (bimetal measuring function) Slave pointer function for the measurement of the RMS value IB Frequency Average value of the currents with sign of the active power (power system only)	4 analogue outputs and bus interface RS 485 (MODBUS)	DME 440
	2 analogue outputs and 4 digital outputs or 4 analogue outputs and 2 digital outputs see Data Sheet DME 424/442-1 Le	DME 424
	Data bus LON see Data Sheet DME 400-1 Le	DME 400



Fig. 1. SINEAX DME 440 in housing T24, clipped onto a top-hat rail.

- **For all heavy-current power system variables**
- **4 analogue outputs**
- **Input voltage up to 693 V (phase-to-phase)**
- **Universal analogue outputs (programmable)**
- **High accuracy: U/I 0.2% and P 0.25% (under reference conditions)**
- **4 integrated energy meters, storage every each 203 s, storage for: 20 years**
- **Windows software with password protection for programming, data analysis, power system status simulation, acquisition of meter data and making settings**
- **DC-, AC-power pack with wide power supply tolerance / universal**
- **Provision for either snapping the transducer onto top-hat rails or securing it with screws to a wall or panel**

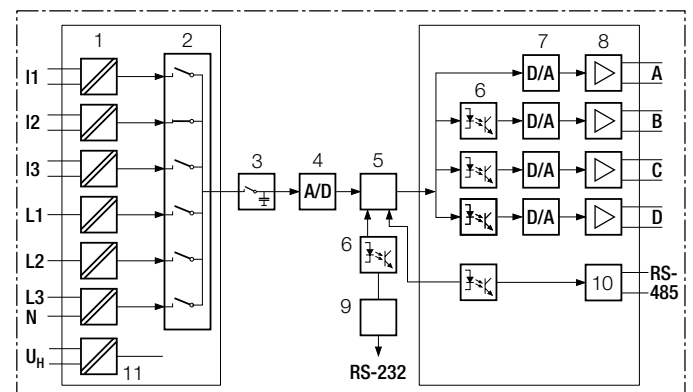

- 1 = Input transformer
- 2 = Multiplexer
- 3 = Latching stage
- 4 = A/D converter
- 5 = Microprocessor
- 6 = Electrical insulation
- 7 = D/A converter
- 8 = Output amplifier / Latching stage
- 9 = Programming interface RS-232
- 10 = Bus RS 485 (MODBUS)
- 11 = Power supply

Fig. 2. Block diagram.

SINEAX DME 440 with RS 485 interface

Programmable multi-transducer

Symbols

Symbols	Meaning	Symbols	Meaning (Continuation)
X	Measured variable	Q	Reactive power of the system $Q = Q1 + Q2 + Q3$
X0	Lower limit of the measured variable	Q1	Reactive power phase 1 (phase-to-neutral L1 – N)
X1	Break point of the measured variable	Q2	Reactive power phase 2 (phase-to-neutral L2 – N)
X2	Upper limit of the measured variable	Q3	Reactive power phase 3 (phase-to-neutral L3 – N)
Y	Output variable	S	Apparent power of the system $S = \sqrt{I_1^2 + I_2^2 + I_3^2} \cdot \sqrt{U_1^2 + U_2^2 + U_3^2}$
Y0	Lower limit of the output variable	S1	Apparent power phase 1 (phase-to-neutral L1 – N)
Y1	Break point of the output variable	S2	Apparent power phase 2 (phase-to-neutral L2 – N)
Y2	Upper limit of the output variable	S3	Apparent power phase 3 (phase-to-neutral L3 – N)
U	Input voltage	Sr	Rated value of the apparent power of the system
Ur	Rated value of the input voltage	PF	Active power factor $\cos\varphi = P/S$
U 12	Phase-to-phase voltage L1 – L2	PF1	Active power factor phase 1 $P1/S1$
U 23	Phase-to-phase voltage L2 – L3	PF2	Active power factor phase 2 $P2/S2$
U 31	Phase-to-phase voltage L3 – L1	PF3	Active power factor phase 3 $P3/S3$
U1N	Phase-to-neutral voltage L1 – N	QF	Reactive power factor $\sin\varphi = Q/S$
U2N	Phase-to-neutral voltage L2 – N	QF1	Reactive power factor phase 1 $Q1/S1$
U3N	Phase-to-neutral voltage L3 – N	QF2	Reactive power factor phase 2 $Q2/S2$
UM	Average value of the voltages $(U1N + U2N + U3N) / 3$	QF3	Reactive power factor phase 3 $Q3/S3$
I	Input current	LF	Power factor of the system $LF = \text{sgn}Q \cdot (1 - PF)$
I1	AC current L1	LF1	Power factor phase 1 $\text{sgn}Q1 \cdot (1 - PF1)$
I2	AC current L2	LF2	Power factor phase 2 $\text{sgn}Q2 \cdot (1 - PF2)$
I3	AC current L3	LF3	Power factor phase 3 $\text{sgn}Q3 \cdot (1 - PF3)$
Ir	Rated value of the input current	c	Factor for the intrinsic error
IM	Average value of the currents $(I1 + I2 + I3) / 3$	R	Output load
IMS	Average value of the currents and sign of the active power (P)	Rn	Rated burden
IB	RMS value of the current with wire setting range (bimetal measuring function)	H	Power supply
IBT	Response time for IB	Hn	Rated value of the power supply
BS	Slave pointer function for the measurement of the RMS value IB	CT	c.t. ratio
BST	Response time for BS	VT	v.t. ratio
φ	Phase-shift between current and voltage		
F	Frequency of the input variable		
Fn	Rated frequency		
P	Active power of the system $P = P1 + P2 + P3$		
P1	Active power phase 1 (phase-to-neutral L1 – N)		
P2	Active power phase 2 (phase-to-neutral L2 – N)		
P3	Active power phase 3 (phase-to-neutral L3 – N)		

Applicable standards and regulations

DIN EN 60 688	Electrical measuring transducers for converting AC electrical variables into analogue and digital signals
IEC 1010 or EN 61 010	Safety regulations for electrical measuring, control and laboratory equipment
EN 60529	Protection types by case (code IP)
IEC 255-4 Part E5	High-frequency disturbance test (static relays only)
IEC 1000-4-2, 3, 4, 6	Electromagnetic compatibility for industrial-process measurement and control equipment
VDI/VDE 3540, page 2	Reliability of measuring and control equipment (classification of climates)
DIN 40 110	AC quantities
DIN 43 807	Terminal markings
IEC 68 /2-6	Basic environmental testing procedures, vibration, sinusoidal
EN 55011	Electromagnetic compatibility of data processing and telecommunication equipment Limits and measuring principles for radio interference and information equipment
IEC 1036	Alternating current static watt-hour meters for active energy (classes 1 and 2)
DIN 43864	Current interface for the transmission of impulses between impulse encoder counter and tariff meter
UL 94	Tests for flammability of plastic materials for parts in devices and appliances

Consumption:

Voltage circuit: $\leq U^2 / 400 \text{ k}\Omega$
 Condition:
 Characteristic XH01 ... XH10
 Current circuit: $0.3 \text{ VA} \cdot I/5 \text{ A}$

Continuous thermal ratings of inputs

Current circuit	10 A 400 V single-phase AC system 693 V three-phase system
Voltage circuit	480 V single-phase AC system 831 V three-phase system

Short-time thermal rating of inputs

Input variable	Number of inputs	Duration of overload	Interval between two overloads
Current circuit	400 V single-phase AC system 693 V three-phase system		
100 A	5	3 s	5 min.
250 A	1	1 s	1 hour
Voltage circuit	1 A, 2 A, 5 A		
Single-phase AC system 600 V $H_{\text{intern}}: 1.5 \text{ Ur}$	10	10 s	10 s
Three-phase system 1040 V $H_{\text{intern}}: 1.5 \text{ Ur}$	10	10 s	10 s

MODBUS® (Bus interface RS-485)

Terminals:	Screw terminals, terminals 23, 24, 25 and 26
Connecting cable:	Screened twisted pair
Max. distance:	Approx. 1200 m (approx. 4000 ft.)
Baudrate:	1200 ... 9600 Bd (programmable)
Number of bus stations:	32 (including master)
Dummy load:	Not required

Technical data

Inputs →

Input variables:	see Table 2 and 3
Measuring ranges:	see Table 2 and 3
Waveform:	Sinusoidal
Rated frequency:	50...60 Hz; 16 2/3 Hz

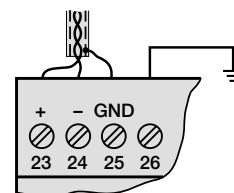

MODBUS® is a registered trademark of the Schneider Automation Inc.

SINEAX DME 440 with RS 485 interface

Programmable multi-transducer

Analogue outputs \rightarrow

For the outputs A, B, C and D:

Output variable Y	Impressed DC current	Impressed DC voltage
Full scale Y2	see "Ordering information"	see "Ordering information"
Limits of output signal for input overload and/or R = 0 R \rightarrow ∞	1.25 · Y2 30 V	40 mA 1.25 Y2
Rated useful range of output load	$0 \leq \frac{7.5 \text{ V}}{Y2} \leq \frac{15 \text{ V}}{Y2}$	$\frac{Y2}{2 \text{ mA}} \leq \frac{Y2}{1 \text{ mA}} \leq \infty$
AC component of output signal (peak-to-peak)	$\leq 0.005 Y2$	$\leq 0.005 Y2$

The outputs A, B, C and D may be either short or open-circuited. They are electrically insulated from each other and from all other circuits (floating).

All the full-scale output values can be reduced subsequently using the programming software, but a supplementary error results.

The hardware full-scale settings for the analogue outputs may also be changed subsequently. Conversion of a current to a voltage output or vice versa is also possible. This necessitates changing resistors on the output board. The full-scale values of the current and voltage outputs are set by varying the effective value of two parallel resistors (better resolution). The values of the resistors are selected to achieve the minimum absolute error. Calibration with the programming software is always necessary following conversion of the outputs. Refer to the Operating Instructions. **Caution: The warranty is void if the device is tampered with!**

Reference conditions

Ambient temperature:	+ 23 °C \pm 1 K
Pre-conditioning:	30 min. acc. to DIN EN 60 688 Section 4.3, Table 2
Input variable:	Rated useful range
Power supply:	H = H _n \pm 1%
Active/reactive factor:	cos ϕ = 1 resp. sin ϕ = 1
Frequency:	50 ... 60 Hz, 16 2/3 Hz
Waveform:	Sinusoidal, form factor 1.1107
Output load:	DC current output: $R_n = \frac{7.5 \text{ V}}{Y2} \pm 1\%$ DC voltage output: $R_n = \frac{Y2}{1 \text{ mA}} \pm 1\%$
Miscellaneous:	DIN EN 60 688

System response

Accuracy class: (the reference value is the full-scale value Y2)

Measured variable	Condition	Accuracy class*
System: Active, reactive and apparent power	$0.5 \leq X2/Sr \leq 1.5$ $0.3 \leq X2/Sr < 0.5$	0.25 c 0.5 c
Phase: Active, reactive and apparent power	$0.167 \leq X2/Sr \leq 0.5$ $0.1 \leq X2/Sr < 0.167$	0.25 c 0.5 c
Power factor, active power and reactive power	$0.5Sr \leq S \leq 1.5 Sr$, (X2 - X0) = 2	0.25 c
	$0.5Sr \leq S \leq 1.5 Sr$, $1 \leq (X2 - X0) < 2$	0.5 c
	$0.5Sr \leq S \leq 1.5 Sr$, $0.5 \leq (X2 - X0) < 1$	1.0 c
	$0.1Sr \leq S < 0.5Sr$, (X2 - X0) = 2	0.5 c
	$0.1Sr \leq S < 0.5Sr$, $1 \leq (X2 - X0) < 2$	1.0 c
AC voltage	$0.1 Ur \leq U \leq 1.2 Ur$	0.2 c
	AC current/ current averages	$0.1 lr \leq l \leq 1.5 lr$
System frequency	$0.1 Ur \leq U \leq 1.2 Ur$ resp. $0.1 lr \leq l \leq 1.5 lr$	0.15 + 0.03 c (f _N = 50...60 Hz) 0.15 + 0.1 c (f _N = 16 2/3 Hz)
Pulse	acc. to IEC 1036 $0.1 lr \leq l \leq 1.5 lr$	1.0

* Basic accuracy 0.5 c for applications with phase-shift

Duration of the measurement cycle: Approx. 0.5 to 1.2 s at 50 Hz, depending on measured variable and programming

Response time: 1 ... 2 times the measurement cycle

Factor c (the highest value applies):

Linear characteristic:	$c = \frac{1 - \frac{Y0}{Y2}}{1 - \frac{X0}{X2}}$ or c = 1
Bent characteristic: X0 \leq X \leq X1	$c = \frac{Y1 - Y0}{X1 - X0} \cdot \frac{X2}{Y2}$ or c = 1
X1 < X \leq X2	$c = \frac{1 - \frac{Y1}{Y2}}{1 - \frac{X1}{X2}}$ or c = 1

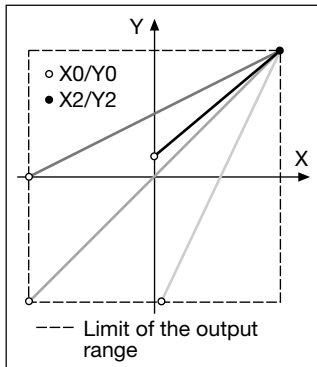

Fig. 3. Examples of settings with linear characteristic.

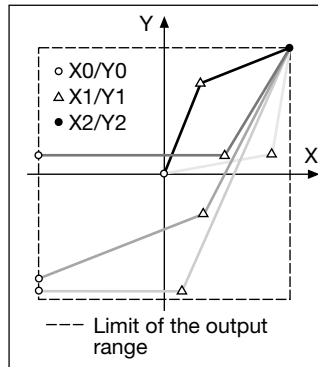

Fig. 4. Examples of settings with bent characteristic.

Influencing quantities and permissible variations

Acc. to DIN IEC 688

Safety

Protection class:	II	
Enclosure protection:	IP 40, housing IP 20, terminals	
Overvoltage category:	III	
Insulation test (versus earth):	Input voltage:	AC 400 V
	Input current:	AC 400 V
	Output:	DC 40 V
	Power supply:	AC 400 V DC 230 V
Surge test:	5 kV; 1.2/50 μ s; 0.5 Ws	
Test voltages:	50 Hz, 1 min. according to DIN EN 61 010-1	
	5550 V, inputs versus all other circuits as well as outer surface	
	3250 V, input circuits versus each other	
	3700 V, power supply versus outputs and SCI as well as outer surface	
	490 V, outputs and SCI versus each other and versus outer surface	

Power supply $\rightarrow \bigcirc$

DC-, AC-power pack (DC and 50 ... 60 Hz)

Table 1: Rated voltages and tolerances

Rated voltage U_N	Tolerance
24 ... 60 V DC/AC	DC - 15 ... + 33%
85 ... 230 V DC/AC	AC \pm 10%

Consumption: \leq 9 W resp. \leq 10 VA

Programming connector on transducer

Interface: RS 232 C
DSUB socket: 9-pin

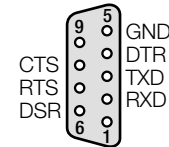

The interface is electrically insulated from all other circuits.

Installation data

Housing: Housing **T24**
See Section "Dimensioned drawings"

Housing material: Lexan 940 (polycarbonate), flammability class V-0 acc. to UL 94, self-extinguishing, non-dripping, free of halogen

Mounting: For snapping onto top-hat rail (35 x 15 mm or 35 x 7.5 mm) acc. to EN 50 022
or
directly onto a wall or panel using the pull-out screw hole brackets

Orientation: Any

Weight: Approx. 0.7 kg

Terminals

Type: Screw terminals with wire guards
Max. wire gauge: \leq 4.0 mm² single wire or
2 x 2.5 mm² fine wire

Vibration withstand

(tested according to DIN EN 60 068-2-6)

Acceleration: \pm 2 g
Frequency range: 10 ... 150 ... 10 Hz, rate of frequency sweep: 1 octave/minute
Number of cycles: 10 in each of the three axes
Result: No faults occurred, no loss of accuracy and no problems with the snap fastener

Ambient conditions

Climatic rating: Climate class 3 acc. to VDI/VDE 3540
Variations due to ambient temperature: \pm 0.1% / 10 K
Nominal range of use for temperature: 0...15...30...45 °C (usage group II)
Storage temperature: -40 to +85 °C
Annual mean relative humidity: \leq 75%

SINEAX DME 440 with RS 485 interface

Programmable multi-transducer

Table 2: Ordering Information

DESCRIPTION	MARKING
1. Mechanical design Housing T24 for rail and wall mounting	440 - 1
2. Rated frequency 1) 50 Hz (60 Hz possible without additional error; 16 2/3 Hz, additional error 1.25 · c) 2) 60 Hz (50 Hz possible without additional error; 16 2/3 Hz, additional error 1.25 · c) 3) 16 2/3 Hz (not re-programming by user, 50/60 Hz possible, but with additional error 1.25 · c)	1 2 3
3. Power supply Nominal range 7) DC/AC 24 ... 60 V 8) DC/AC 85 ... 230 V	7 8
4. Power supply connection 1) External (standard) 2) Internal from voltage input Line 2: Not available for rated frequency 16 2/3 Hz and applications A15 / A16 / A24 (see Table 3) Caution: The power supply voltage must agree with the input voltage (Table 3)	1 2
5. Full-scale output signal, output A 1) Output A, Y2 = 20 mA (standard) 9) Output A, Y2 [mA] Z) Output A, Y2 [V] Line 9: Full-scale current Y2 [mA] 1 to 20 Line Z: Full-scale voltage Y2 [V] 1 to 10	1 9 Z
6. Full-scale output signal, output B 1) Output B, Y2 = 20 mA (standard) 9) Output B, Y2 [mA] Z) Output B, Y2 [V]	1 9 Z
7. Full-scale output signal, output C 1) Output C, Y2 = 20 mA (standard) 9) Output C, Y2 [mA] Z) Output C, Y2 [V]	1 9 Z
8. Full-scale output signal, output D 1) Output D, Y2 = 20 mA (standard) 9) Output D, Y2 [mA] Z) Output D, Y2 [V]	1 9 Z
9. Test certificate 0) None supplied 1) Supplied	0 1
10. Programming 0) Basic 9) According to specification Line 0: Not available if the power supply is taken from the voltage input Line 9: All the programming data must be entered on Form W 2389e and the form must be included with the order.	0 9

Table 3: Programming

DESCRIPTION	A11 ... A16	Application A34	A24 / A44
1. Application (system)			
Single-phase AC	A11	—	—
3-wire, 3-phase symmetric load, phase-shift U: L1-L2, I: L1 *	A12	—	—
3-wire, 3-phase symmetric load	A13	—	—
4-wire, 3-phase symmetric load	A14	—	—
3-wire, 3-phase symmetric load, phase-shift U: L3-L1, I: L1 *	A15	—	—
3-wire, 3-phase symmetric load, phase-shift U: L2-L3, I: L1 *	A16	—	—
3-wire, 3-phase asymmetric load	—	A34	—
4-wire, 3-phase asymmetric load	—	—	A44
4-wire, 3-phase asymmetric load, open-Y	—	—	A24
2. Input voltage			
Rated value $U_r = 57.7$ V	U01	—	—
Rated value $U_r = 63.5$ V	U02	—	—
Rated value $U_r = 100$ V	U03	—	—
Rated value $U_r = 110$ V	U04	—	—
Rated value $U_r = 120$ V	U05	—	—
Rated value $U_r = 230$ V	U06	—	—
Rated value U_r [M] 	U91	—	—
Rated value $U_r = 100$ V	U21	U21	U21
Rated value $U_r = 110$ V	U22	U22	U22
Rated value $U_r = 115$ V	U23	U23	U23
Rated value $U_r = 120$ V	U24	U24	U24
Rated value $U_r = 400$ V	U25	U25	U25
Rated value $U_r = 500$ V	U26	U26	U26
Rated value U_r [M] 	U93	U93	U93
Lines U01 to U06: Only for single phase AC current or 4-wire, 3-phase symmetric load			
Line U91: U_r [M] 57 to 400			
Line U93: U_r [M] > 100 to 693			
3. Input current			
Rated value $I_r = 1$ A V1	V1	V1	
Rated value $I_r = 2$ A V2	V2	V2	
Rated value $I_r = 5$ A V3	V3	V3	
Rated value $I_r > 1$ to 6 [A] 	V9	V9	V9
4. Primary rating (primary transformer)			
Without specification of primary rating	W0	W0	W0
CT = A / A VT = kV / V	W9	W9	W9
Line W9: Specify transformer ratio prim./sec., e.g. 1000/5 A; 33 kV/110 V			

* Basic accuracy 0.5 c

Table 3 continued on next page!

SINEAX DME 440 with RS 485 interface

Programmable multi-transducer

Continuation "Table 3: Programming"

DESCRIPTION				A11 ... A16	Application A34	A24 / A44
5. Measured variable, output A						
Not used				AA000	AA000	AA000
		Initial value X0	Final value X2			
U	System	X0 = 0	X2 = Ur*	AA001	—	—
U12	L1-L2	X0 = 0	X2 = Ur*	—	AA001	AA001
U	System	0 ≤ X0 ≤ 0.9 · X2	0.8 · Ur ≤ X2 ≤ 1.2 · Ur*	AA901	—	—
U1N	L1-N	0 ≤ X0 ≤ 0.9 · X2	0.8 · Ur/√3 ≤ X2 ≤ 1.2 · Ur/√3 *	—	—	AA902
U2N	L2-N	0 ≤ X0 ≤ 0.9 · X2	0.8 · Ur/√3 ≤ X2 ≤ 1.2 · Ur/√3 *	—	—	AA903
U3N	L3-N	0 ≤ X0 ≤ 0.9 · X2	0.8 · Ur/√3 ≤ X2 ≤ 1.2 · Ur/√3 *	—	—	AA904
U12	L1-L2	0 ≤ X0 ≤ 0.9 · X2	0.8 · Ur ≤ X2 ≤ 1.2 · Ur*	—	AA905	AA905
U23	L2-L3	0 ≤ X0 ≤ 0.9 · X2	0.8 · Ur ≤ X2 ≤ 1.2 · Ur*	—	AA906	AA906
U31	L3-L1	0 ≤ X0 ≤ 0.9 · X2	0.8 · Ur ≤ X2 ≤ 1.2 · Ur*	—	AA907	AA907
I	System	0 ≤ X0 ≤ 0.8 · X2	0.5 · Ir ≤ X2 ≤ 1.5 · Ir	AA908	—	—
I1	L1	0 ≤ X0 ≤ 0.8 · X2	0.5 · Ir ≤ X2 ≤ 1.5 · Ir	—	AA909	AA909
I2	L2	0 ≤ X0 ≤ 0.8 · X2	0.5 · Ir ≤ X2 ≤ 1.5 · Ir	—	AA910	AA910
I3	L3	0 ≤ X0 ≤ 0.8 · X2	0.5 · Ir ≤ X2 ≤ 1.5 · Ir	—	AA911	AA911
P	System	-X2 ≤ X0 ≤ 0.8 · X2	0.3 ≤ X2 / Sr ≤ 1.5	AA912	AA912	AA912
P1	L1	-X2 ≤ X0 ≤ 0.8 · X2	0.1 ≤ X2 / Sr ≤ 0.5	—	—	AA913
P2	L2	-X2 ≤ X0 ≤ 0.8 · X2	0.1 ≤ X2 / Sr ≤ 0.5	—	—	AA914
P3	L3	-X2 ≤ X0 ≤ 0.8 · X2	0.1 ≤ X2 / Sr ≤ 0.5	—	—	AA915
Q	System	-X2 ≤ X0 ≤ 0.8 · X2	0.3 ≤ X2 / Sr ≤ 1.5	AA916	AA916	AA916
Q1	L1	-X2 ≤ X0 ≤ 0.8 · X2	0.1 ≤ X2 / Sr ≤ 0.5	—	—	AA917
Q2	L2	-X2 ≤ X0 ≤ 0.8 · X2	0.1 ≤ X2 / Sr ≤ 0.5	—	—	AA918
Q3	L3	-X2 ≤ X0 ≤ 0.8 · X2	0.1 ≤ X2 / Sr ≤ 0.5	—	—	AA919
PF	System	-1 ≤ X0 ≤ (X2 - 0.5)	0 ≤ X2 ≤ 1	AA920	AA920	AA920
PF1	L1	-1 ≤ X0 ≤ (X2 - 0.5)	0 ≤ X2 ≤ 1	—	—	AA921
PF2	L2	-1 ≤ X0 ≤ (X2 - 0.5)	0 ≤ X2 ≤ 1	—	—	AA922
PF3	L3	-1 ≤ X0 ≤ (X2 - 0.5)	0 ≤ X2 ≤ 1	—	—	AA923
QF	System	-1 ≤ X0 ≤ (X2 - 0.5)	0 ≤ X2 ≤ 1	AA924	AA924	AA924
QF1	L1	-1 ≤ X0 ≤ (X2 - 0.5)	0 ≤ X2 ≤ 1	—	—	AA925
QF2	L2	-1 ≤ X0 ≤ (X2 - 0.5)	0 ≤ X2 ≤ 1	—	—	AA926
QF3	L3	-1 ≤ X0 ≤ (X2 - 0.5)	0 ≤ X2 ≤ 1	—	—	AA927
F		15.3 Hz ≤ X0 ≤ X2 - 1 Hz	X0 + 1 Hz ≤ X2 ≤ 65 Hz	AA928	AA928	AA928
S	System	0 ≤ X0 ≤ 0.8 · X2	0.3 ≤ X2 / Sr ≤ 1.5	AA929	AA929	AA929
S1	L1	0 ≤ X0 ≤ 0.8 · X2	0.1 ≤ X2 / Sr ≤ 0.5	—	—	AA930
S2	L2	0 ≤ X0 ≤ 0.8 · X2	0.1 ≤ X2 / Sr ≤ 0.5	—	—	AA931
S3	L3	0 ≤ X0 ≤ 0.8 · X2	0.1 ≤ X2 / Sr ≤ 0.5	—	—	AA932
IM	System	0 ≤ X0 ≤ 0.8 · X2	0.5 · Ir ≤ X2 ≤ 1.5 · Ir	—	AA933	AA933
IMS	System	-X2 ≤ X0 ≤ 0.8 · X2	0.5 · Ir ≤ X2 ≤ 1.5 · Ir	—	AA934	AA934
LF	System	-1 ≤ X0 ≤ (X2 - 0.5)	0 ≤ X2 ≤ 1	AA935	AA935	AA935
LF1	L1	-1 ≤ X0 ≤ (X2 - 0.5)	0 ≤ X2 ≤ 1	—	—	AA936
LF2	L2	-1 ≤ X0 ≤ (X2 - 0.5)	0 ≤ X2 ≤ 1	—	—	AA937
LF3	L3	-1 ≤ X0 ≤ (X2 - 0.5)	0 ≤ X2 ≤ 1	—	—	AA938
IB	System	X0 = 0 1 ≤ IBT ≤ 30 min	0.5 · Ir ≤ X2 ≤ 1.5 · Ir	AA939	—	—
IB1	L1	X0 = 0 1 ≤ IBT ≤ 30 min	0.5 · Ir ≤ X2 ≤ 1.5 · Ir	—	AA940	AA940
IB2	L2	X0 = 0 1 ≤ IBT ≤ 30 min	0.5 · Ir ≤ X2 ≤ 1.5 · Ir	—	AA941	AA941
IB3	L3	X0 = 0 1 ≤ IBT ≤ 30 min	0.5 · Ir ≤ X2 ≤ 1.5 · Ir	—	AA942	AA942
BS	System	X0 = 0 1 ≤ BST ≤ 30 min	0.5 · Ir ≤ X2 ≤ 1.5 · Ir	AA943	—	—
BS1	L1	X0 = 0 1 ≤ BST ≤ 30 min	0.5 · Ir ≤ X2 ≤ 1.5 · Ir	—	AA944	AA944
BS2	L2	X0 = 0 1 ≤ BST ≤ 30 min	0.5 · Ir ≤ X2 ≤ 1.5 · Ir	—	AA945	AA945
BS3	L3	X0 = 0 1 ≤ BST ≤ 30 min	0.5 · Ir ≤ X2 ≤ 1.5 · Ir	—	AA946	AA946
UM	System	0 ≤ X0 ≤ 0.8 · X2	0.8 · Ur ≤ X2 ≤ 1.2 · Ur*	—	—	AA947

* Where the power supply is taken from the measured voltage, the transmitter only operates in the range $U = 0.8 Ur \dots 1.2 Ur$ and the specified accuracy is only guaranteed in the range $U = 0.9 Ur \dots 1.1 Ur$.

Table 3 continued on next page!

Continuation "Table 3: Programming"

DESCRIPTION	Application		
	A11 ... A16	A34	A24 / A44
6. Output signal, output A			
Initial value Y0			
Final value Y2			
DC current	Y0 = 0	Y2 = 20 mA	
	$-Y2 \leq Y0 \leq 0.2 \cdot Y2$	$1 \text{ mA} \leq Y2 \leq 20 \text{ mA}$	
DC voltage			
	$-Y2 \leq Y0 \leq 0.2 \cdot Y2$	$1 \text{ V} \leq Y2 \leq 10 \text{ V}$	
7. Characteristic, output A			
Linear			
Bent	$(X0 + 0.015 \cdot X2) \leq X1 \leq 0.985 \cdot X2$	$Y0 \leq Y1 \leq Y2$	
8. Limits, output A			
Standard	$Y_{\min} = Y0 - 0.25 Y2$	$Y_{\max} = 1.25 Y2$	
	$(Y0 - 0.25 Y2) \leq Y_{\min} \leq Y0$	$Y2 \leq Y_{\max} \leq 1.25 Y2$	
9. Measured variable, output B			
Same as output A, but markings start with a capital B	BA ...	BA ...	BA ...
10. Output signal, output B			
Same as output A, but markings start with a capital B	BB ..	BB ..	BB ..
11. Characteristic, output B			
Same as output A, but markings start with a capital B	BC ..	BC ..	BC ..
12. Limits, output B			
Same as output A, but markings start with a capital B	BD ..	BD ..	BD ..
13. Measured variable, output C			
Same as output A, but markings start with a capital C	CA ...	CA ...	CA ...
14. Output signal, output C			
Same as output A, but markings start with a capital C	CB ..	CB ..	CB ..
15. Characteristic, output C			
Same as output A, but markings start with a capital C	CC ..	CC ..	CC ..
16. Limits, output C			
Same as output A, but markings start with a capital C	CD ..	CD ..	CD ..
17. Measured variable, output D			
Same as output A, but markings start with a capital D	DA ..	DA ..	DA ..
18. Output signal, output D			
Same as output A, but markings start with a capital D	DB ..	DB ..	DB ..

Table 3 continued on next page!







SINEAX DME 440 with RS 485 interface

Programmable multi-transducer

Continuation "Table 3: Programming"

DESCRIPTION	Application		
	A11 ... A16	A34	A24 / A44
19. Characteristic, output D Same as output A, but markings start with a capital D	DC ..	DC ..	DC ..
20. Limits, output D Same as output A, but markings start with a capital D	DD ..	DD ..	DD ..
21. Power meter 1 Not used	EA00	EA00	EA00
I System [Ah]	EA50	—	—
I1 L1 [Ah]	—	EA51	EA51
I2 L2 [Ah]	—	EA52	EA52
I3 L3 [Ah]	—	EA53	EA53
S System [VAh]	EA54	EA54	EA54
S1 L1 [VAh]	—	—	EA55
S2 L2 [VAh]	—	—	EA56
S3 L3 [VAh]	—	—	EA57
P System (incoming) [Wh]	EA58	EA58	EA58
P1 L1 (incoming) [Wh]	—	—	EA59
P2 L2 (incoming) [Wh]	—	—	EA60
P3 L3 (incoming) [Wh]	—	—	EA61
Q System (inductive) [Varh]	EA62	EA62	EA62
Q1 L1 (inductive) [Varh]	—	—	EA63
Q2 L2 (inductive) [Varh]	—	—	EA64
Q3 L3 (inductive) [Varh]	—	—	EA65
P System (outgoing) [Wh]	EA66	EA66	EA66
P1 L1 (outgoing) [Wh]	—	—	EA67
P2 L2 (outgoing) [Wh]	—	—	EA68
P3 L3 (outgoing) [Wh]	—	—	EA69
Q System (capacitive) [Varh]	EA70	EA70	EA70
Q1 L1 (capacitive) [Varh]	—	—	EA71
Q2 L2 (capacitive) [Varh]	—	—	EA72
Q3 L3 (capacitive) [Varh]	—	—	EA73
22. Energy meter 2 Same as energy meter 1, but markings start with a capital F	FA ..	FA ..	FA ..
23. Energy meter 3 Same as energy meter 1, but markings start with a capital G	GA ..	GA ..	GA ..
24. Energy meter 4 Same as energy meter 1, but markings start with a capital H	HA ..	HA ..	HA ..

Electrical connections

Function			Connect.	
Measuring input 	AC current	IL1	1 / 3	
		IL2	4 / 6	
		IL3	7 / 9	
	AC voltage	UL1	2	
		UL2	5	
		UL3	8	
N		11		
Outputs 	Analogue	 A	+	15
			-	16
		 B	+	17
			-	18
		 C	+	19
			-	20
		 D	+	21
			-	22
RS 485 (MODBUS)	Tx+/Rx+		23	
	Tx-/Rx-		24	
	GND		25	
			26	
Power supply 	AC	~	13	
		~	14	
	DC	+	13	
		-	14	

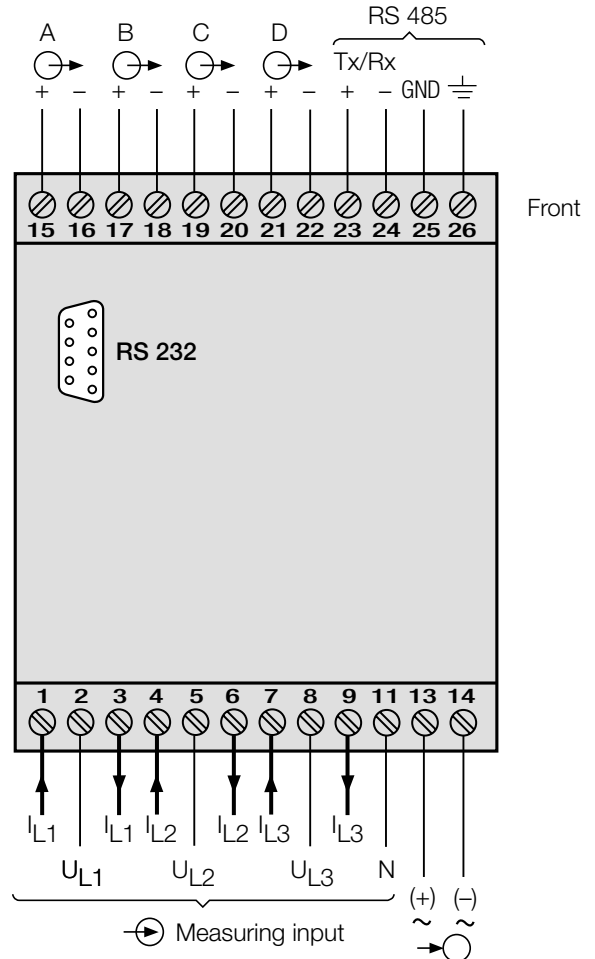

If power supply is taken from the measured voltage internal connections are as follow:

Application (system)	Internal connection Terminal / System
Single-phase AC current	2 / 11 (L1 - N)
4-wire 3-phase symmetric load	2 / 11 (L1 - N)
All other (apart from A15 / A16 / A24)	2 / 5 (L1 - L2)

Measuring inputs

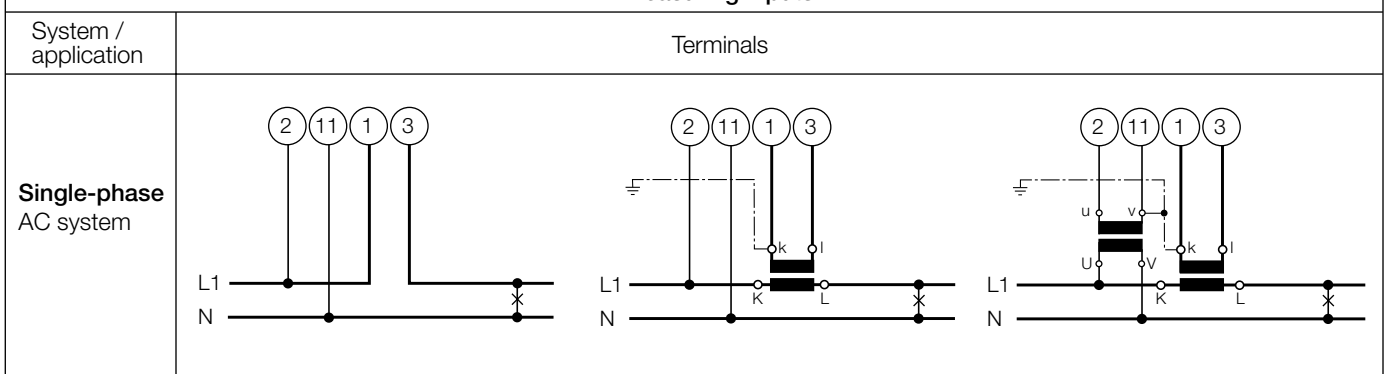

SINEAX DME 440 with RS 485 interface

Programmable multi-transducer

Measuring inputs																		
System / application	Terminals																	
3-wire 3-phase symmetric load I: L1	<p>Connect the voltage according to the following table for current measurement in L2 or L3:</p> <table border="1"> <thead> <tr> <th>Current transf.</th> <th>Terminals</th> <th>2</th> <th>5</th> <th>8</th> </tr> </thead> <tbody> <tr> <td>L2</td> <td>1</td> <td>3</td> <td>L2</td> <td>L3</td> <td>L1</td> </tr> <tr> <td>L3</td> <td>1</td> <td>3</td> <td>L3</td> <td>L1</td> <td>L2</td> </tr> </tbody> </table>	Current transf.	Terminals	2	5	8	L2	1	3	L2	L3	L1	L3	1	3	L3	L1	L2
Current transf.	Terminals	2	5	8														
L2	1	3	L2	L3	L1													
L3	1	3	L3	L1	L2													
3-wire 3-phase symmetric load Phase-shift U: L1 – L2 I: L1	<p>Connect the voltage according to the following table for current measurement in L2 or L3:</p> <table border="1"> <thead> <tr> <th>Current transf.</th> <th>Terminals</th> <th>2</th> <th>5</th> </tr> </thead> <tbody> <tr> <td>L2</td> <td>1</td> <td>3</td> <td>L2</td> <td>L3</td> </tr> <tr> <td>L3</td> <td>1</td> <td>3</td> <td>L3</td> <td>L1</td> </tr> </tbody> </table>	Current transf.	Terminals	2	5	L2	1	3	L2	L3	L3	1	3	L3	L1			
Current transf.	Terminals	2	5															
L2	1	3	L2	L3														
L3	1	3	L3	L1														
3-wire 3-phase symmetric load Phase-shift U: L3 – L1 I: L1	<p>Connect the voltage according to the following table for current measurement in L2 or L3:</p> <table border="1"> <thead> <tr> <th>Current transf.</th> <th>Terminals</th> <th>8</th> <th>2</th> </tr> </thead> <tbody> <tr> <td>L2</td> <td>1</td> <td>3</td> <td>L1</td> <td>L2</td> </tr> <tr> <td>L3</td> <td>1</td> <td>3</td> <td>L2</td> <td>L3</td> </tr> </tbody> </table>	Current transf.	Terminals	8	2	L2	1	3	L1	L2	L3	1	3	L2	L3			
Current transf.	Terminals	8	2															
L2	1	3	L1	L2														
L3	1	3	L2	L3														

Measuring inputs

System / application

Terminals

3-wire
3-phase
symmetric load
Phase-shift
U: L2 – L3
I: L1

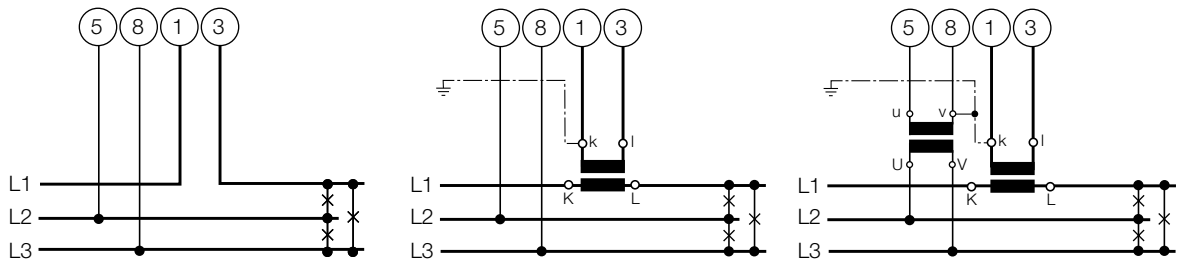

Connect the voltage according to the following table for current measurement in L2 or L3:

Current transf.	Terminals		5	8
	1	3		
L2	1	3	L3	L1
L3	1	3	L1	L2

4-wire
3-phase
symmetric load
I: L1

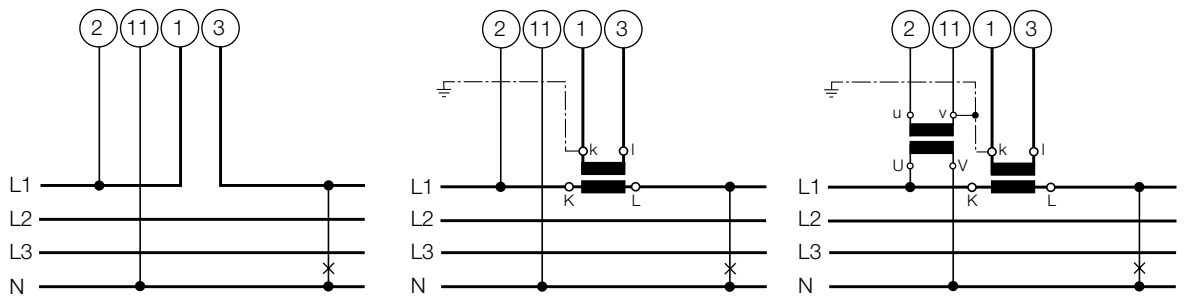

Connect the voltage according to the following table for current measurement in L2 or L3:

Current transf.	Terminals		2	11
	1	3		
L2	1	3	L2	N
L3	1	3	L3	N

3-wire
3-phase
asymmetric load

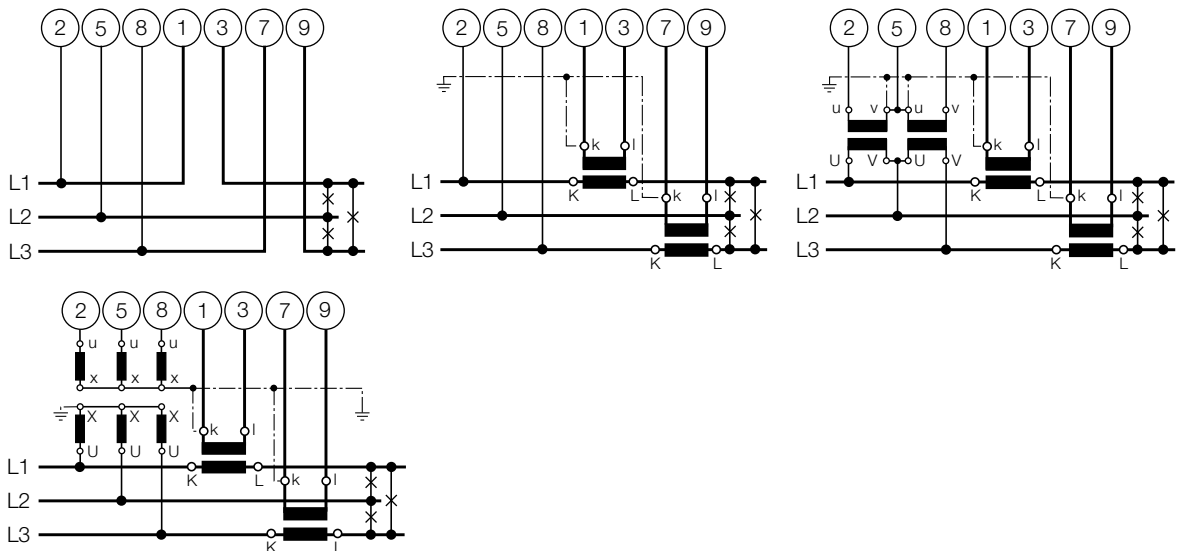

SINEAX DME 440 with RS 485 interface

Programmable multi-transducer

Messeingänge	
Netzformen / Anwendung	Klemmenbelegung
Vierleiter-Drehstromnetz ungleich-belastet	
	<p>3 einpolig isolierte Spannungswandler im Hochspannungsnetz</p>
Vierleiter-Drehstromnetz ungleich-belastet, Open Y Schaltung	
	<p>Niederspannungsnetz</p> <p>2 einpolig isolierte Spannungswandler im Hochspannungsnetz</p>

Relationship between PF, QF and LF

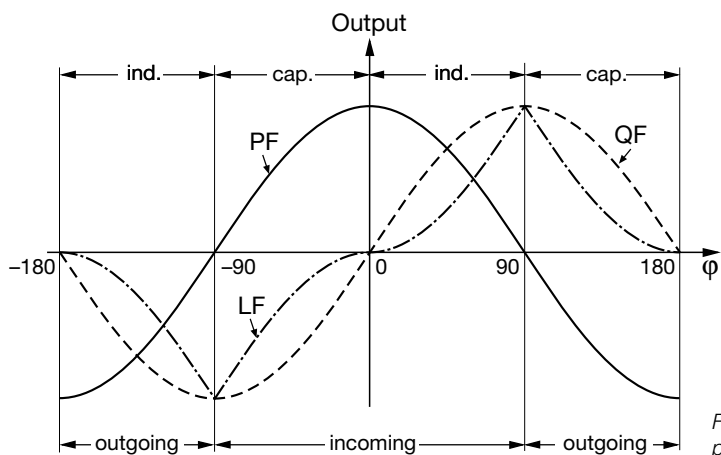

Fig. 5. Active power PF —, reactive power QF -----, power factor LF -.-.-.

Connecting devices to the bus

The RS 485 interface of the DME 440 is galvanically isolated from all other circuits. For an optimal data transmission the devices are connected via a 3-wire cable, consisting of a twisted pair cable (for data lines) and a shield. There is no termination required. A shield both prevents the coupling of external noise to the bus and limits emissions from the bus. The shield must be connected to solid ground.

You can connect up to 32 members to the bus (including master). Basically devices of different manufacturers can be connected to the bus, if they use the standard MODBUS[®] protocol. Devices without galvanically isolated bus interface are not allowed to be connected to the shield.

The optimal topology for the bus is the daisy chain connection from node 1 to node 2 to node n. The bus must form a single continuous path, and the nodes in the middle of the bus must have short stubs. Longer stubs would have a negative impact on signal quality (reflexion at the end). A star or even ring topology is not allowed.

There is no bus termination required due to low data rate. If you got problems when using long cables you can terminate the bus at both ends with the characteristic impedance of the cable (normally about 120 Ω). Interface converters RS 232 ↔ RS 485 or RS 485 interface cards often have a built-in termination network which can be connected to the bus. The second impedance then can be connected directly between the bus terminals of the device far most.

Fig. 6 shows the connection of transducers DME 440 to the MODBUS. The RS 485 interface can be realized by means of PC built-in interface cards or interface converters. Both is shown using i.e. the interfaces 13601 and 86201 of W & T (Wiesemann & Theis GmbH). They are configured for a 2-wire application with automatic control of data direction. These interfaces provide a galvanical isolation and a built-in termination network.

Important:

- Each device connected to the bus must have a unique address
- All devices must be adjusted to the same baudrate.

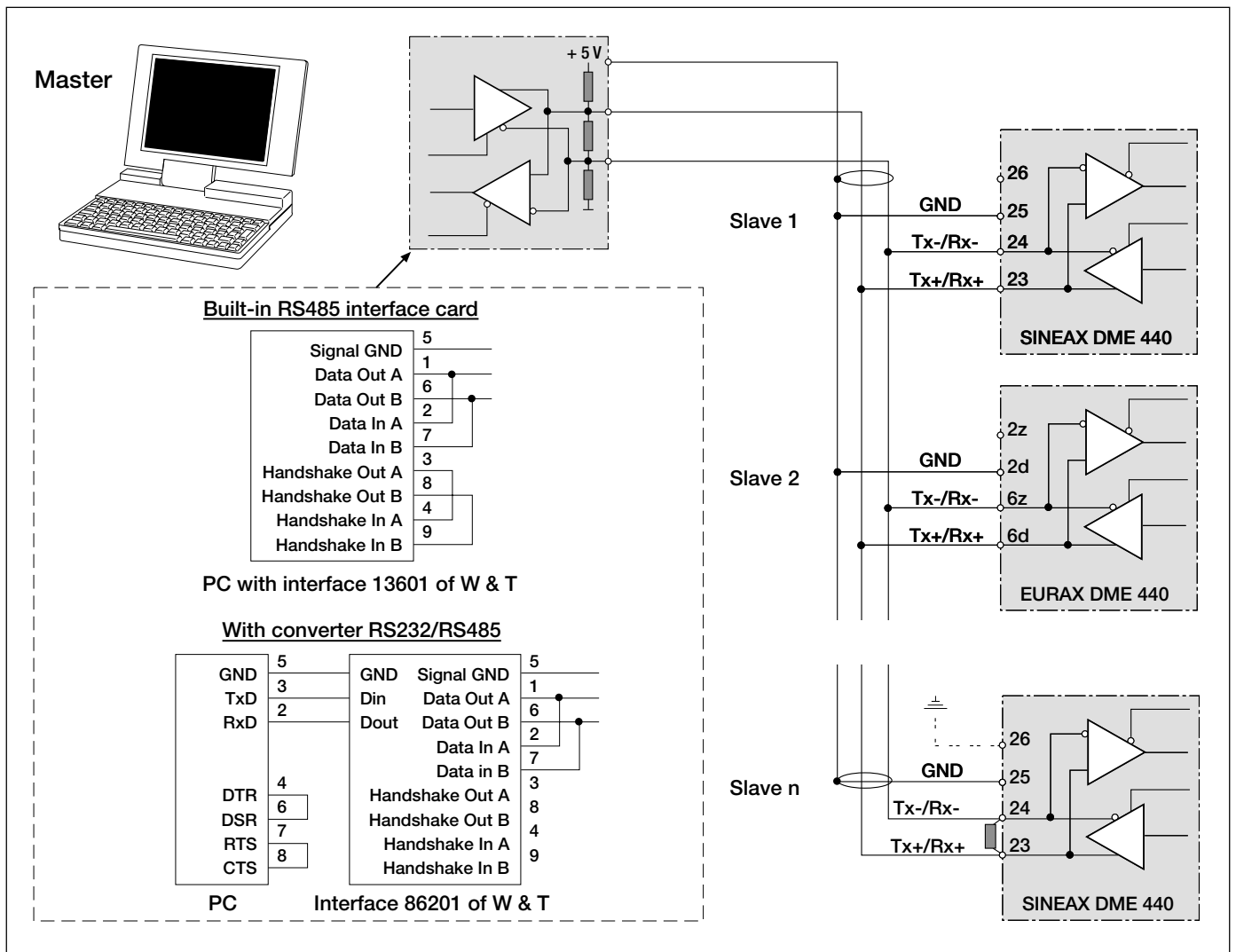

Fig. 6

SINEAX DME 440 with RS 485 interface

Programmable multi-transducer

Dimensioned drawings

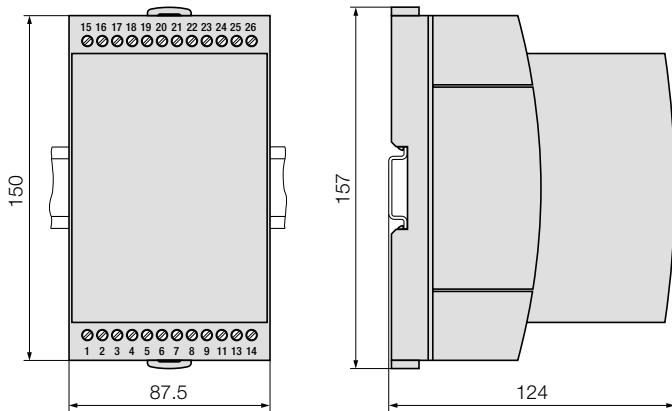

Fig. 7. SINEAX DME 440 in housing **T24** clipped onto a top-hat rail (35 x 15 mm or 35 x 7.5 mm, acc. to EN 50 022).

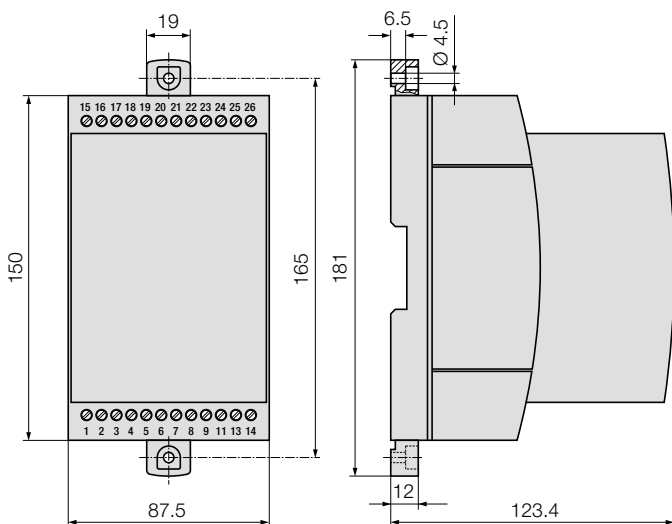

Fig. 8. SINEAX DME 440 in housing **T24**, screw hole mounting brackets pulled out.

Table 4: Accessories

Description	Order No.
Programming cable	980 179
PC software DME 4 (in German, English and French on two 3 1/2" discs)	131 144
Software METRAWin 10 / DME 440	128 373
Operating Instructions DME 440-1 B d-f-e	127 127

Standard accessories

- 1 Operating Instructions for EURAX DME 440 in three languages: German, French, English
- 1 blank type label, for recording programmed settings
- 1 Interface definition DME 440: German, French or English