

# SINEAX PT 602, 1 or 2 channels

## Configurable transmitter for Pt 100

In housing S17 for rail and wall mounting



### Application

The transmitter **SINEAX PT 602** (Fig. 1 and 2) converts the input variable – a signal from a resistance thermometer Pt 100 – to a temperature linear output signal.

The analogue output signal is either an impressed current or superimposed voltage which is processed by other devices for purposes of displaying, recording and/or regulating a constant.

Versions are available for two, three or four-wire connection.

DIP switches are provided for the coarse setting of the measuring range and the fine adjustment is accomplished using the potentiometers.

Red LED's signal an open or short-circuit feeler. In both cases, the output signal adopts its maximum value.

In the case of a current output, provision is made for switching between 0...20 mA and 4...20 mA.

The transmitter fulfils all the important requirements and regulations concerning electromagnetic compatibility **EMC** and **Safety** (IEC 1010 resp. EN 61 010). It was developed and is manufactured and tested in strict accordance with the **quality assurance standard** ISO 9001.

### Features / Benefits

- Measuring ranges configurables with DIP switch and potentiometer
- Red LED's signal an open or short-circuit feeler
- Electric insulation between input, output 2.3 kV and power supply 3.7 kV / Fulfils EN 61 010
- Non-standard user-specific ranges available
- AC/DC power supply / Universal
- Provision for either snapping the transmitter onto top-hat rails or securing it with screws to a wall or panel
- Housing only 17.5 mm wide (size S17) / Low space requirement

### Standard versions

Input(s) set to a range of 0...100 °C and output(s) to a range of 4...20 mA. Configured for three-wire connection. DIP switches enable the temperature range to be configured between a minimum of -170 °C to a maximum of + 800 °C; potentiometers for fine calibration of "Zero" and "Span".

**Table 1: Standard version with 1 input and 1 output**

Input	Output	Power supply DC/AC	Order No.
0...100 °C configurable	0/4...20 mA $R_{ext.} \leq 500 \Omega$	24... 60 V	125 650
		85...230 V	125 668



Fig. 1. SINEAX PT 602, 1 channel version, in housing S17 clipped onto a top-hat rail.



Fig. 2. SINEAX PT 602, 2 channels version, in housing S17 screw hole mounting brackets pulled out.

**Table 2: Standard version with 2 inputs and 2 outputs**

Inputs 1 and 2	Outputs 1 and 2	Power supply DC/AC	Order No.
0...100 °C configurable	0/4...20 mA $R_{ext.} \leq 500 \Omega$	24... 60 V	125 676
		85...230 V	125 684

Please complete the Order Code 602-1... .... according to "Table 4: Ordering informations" for versions with user-specific configuration.

# SINEAX PT 602, 1 or 2 channels

## Configurable transmitter for Pt 100

### Technical data

#### Measuring input resp. measuring inputs $\rightarrow$

Resistance thermometer:	Type Pt 100 (DIN IEC 751)
Measuring current:	< 1 mA
Input resistance:	$R_i > 4 \text{ M}\Omega$
Lead resistance:	Two-wire connection $\leq 25 \Omega$ per lead (total $50 \Omega$ ) Three-/four-wire connection $\leq 25 \Omega$ per lead
Temperature range:	Two-wire connection $-150 \dots 800 \text{ }^\circ\text{C}$ Three-/four-wire connection $-170 \dots 800 \text{ }^\circ\text{C}$
Min. span:	$50 \text{ }^\circ\text{C}$
Max. span:	$700 \text{ }^\circ\text{C}$
Max. initial value:	Two-wire connection $400 \text{ }^\circ\text{C}$ Three-/four-wire connection $500 \text{ }^\circ\text{C}$
Max. ratio between offset and span:	$\frac{T_A}{T_E - T_A} < 10$ ( $T_A$ and $T_E$ in $^\circ\text{C}$ )
Measuring range settings:	– Coarse setting with DIP switches – Fine adjustment with potentiometers “Zero” and “Span”
Potentiometer setting range:	Dependent on temperature range, typical values: – Span, approx. $\pm 60\%$ of full scale – Offset, approx. $\pm 100 \text{ }^\circ\text{C}$ (12-turn helical potentiometers)

#### Measuring output resp. measuring outputs $\rightarrow$

DC current:	$0/4 \dots 20 \text{ mA}$ switchable by plug-in jumper
Burden voltage:	$10 \text{ V}$
Open-circuit voltage:	$< 20 \text{ V}$
External resistance:	$R_{\text{ext. max.}} \leq 500 \Omega$
Residual ripple:	$< 1.5\% \text{ p.p., DC} \dots 10 \text{ kHz}$
DC voltage:	$0 \dots 10 \text{ V}$
Short-circuit current:	$\leq 40 \text{ mA}$
Load capacity:	$R_{\text{ext. min.}} \geq 2 \text{ k}\Omega$
Residual ripple:	$< 1.5\% \text{ p.p., DC} \dots 10 \text{ kHz}$
Response time:	$\leq 500 \text{ ms}$

#### Open-circuit sensor circuit and short-circuit supervision $\frac{1}{4}$

Pick-up level:	– At open-circuit approx. $1 \text{ to } 400 \text{ k}\Omega$ – At short-circuit approx. $0 \dots 30 \Omega$
----------------	---

Fault signalling mode:	– Frontplate signals Red LED for signalling fault – Output signal at $0/4 \dots 20 \text{ mA}$ , output approx. $25 \text{ mA}$ at $0 \dots 10 \text{ V}$ , output approx. $12.5 \text{ V}$
------------------------	---

#### Power supply H $\rightarrow$

AC/DC power pack (DC and  $45 \dots 400 \text{ Hz}$ )

Table 3: Rated voltages and permissible variations

Nominal voltages $U_N$	Permissible variation
$24 \dots 60 \text{ V DC / AC}$	DC $-15 \dots +33\%$ AC $\pm 15\%$
$85 \dots 230 \text{ V } ^1 \text{ DC / AC}$	

Power consumption:	1 channel version $\leq 1.2 \text{ W}$ resp. $\leq 2.3 \text{ VA}$ 2 channels version $\leq 1.8 \text{ W}$ resp. $\leq 3.4 \text{ VA}$
--------------------	---

#### Accuracy data (acc. to DIN/IEC 770)

Basic accuracy:	Max. error $\leq \pm 0.5\%$ including linearity and repeatability errors for a standard range $0 \dots 100 \text{ }^\circ\text{C}$ and for reference conditions
Additional error (additive):	$\leq \pm 0.35\%$ for linearised characteristic
Influence of lead resistance:	– Two-wire connection: Compensated by potentiometer – Three-wire connection: $0.15 \text{ K}$ of measuring range per $10 \Omega$ Lead resistance $\geq 0.375 \text{ K}$ total – Four-wire connection: $0.1 \text{ K}$ of measuring range per $10 \Omega$ Lead resistance $\geq 0.375 \text{ K}$ total
Selector switch for $0 \dots 20 / 4 \dots 20 \text{ mA}$ :	$\pm 0.1\%$

#### Reference conditions:

Ambient temperature	$23 \text{ }^\circ\text{C}, \pm 2 \text{ K}$
Power supply	$24 \text{ V DC} \pm 10\%$ and $230 \text{ V AC} \pm 10\%$
Output burden	Current: $0.5 \cdot R_{\text{ext. max.}}$ Voltage: $2 \cdot R_{\text{ext. min.}}$

<sup>1</sup> An external supply fuse with a rupture capacity  $\leq 20 \text{ A}$  must be provided for DC supply voltages  $> 125 \text{ V}$ .

**Influencing factors:**

Temperature	< ± 0.2% per 10 K
Burden	< ± 0.1% for current output < 0.2% for voltage output, if $R_{ext} > 2 \cdot R_{ext\ min.}$
Long-term drift	< ± 0.3% / 12 months
Switch-on drift	< ± 0.5%

Overvoltage category  
acc. to IEC 664:

III for power supply  
II for measuring input and measuring  
output

Double insulation:

– Power supply versus all circuits  
– Measuring input versus measuring  
output

Test voltage:

Power supply versus:  
– all 3.7 kV, 50 Hz, 1 min.

Measuring inputs versus:  
– measuring outputs 2.3 kV, 50 Hz,  
1 min.

Measuring input 1 versus:  
– measuring input 2  
2.3 kV, 50 Hz, 1 min.

Measuring output 1 versus:  
– measuring output 2  
2.3 kV, 50 Hz, 1 min.

**Installation data**

Mechanical design:	Housing S17 Refer to Section “Dimensional drawings” for dimensions
Material of housing:	Lexan 940 (polycarbonate) Flammability Class V-0 acc. to UL 94, self-extinguishing, non-dripping, free of halogen
Mounting:	For snapping onto top-hat rail (35 × 15 mm or 35 × 7.5 mm) acc. to EN 50 022 or directly onto a wall or panel using the pull-out screw hole brackets
Mounting position:	Any
Terminals:	DIN/VDE 0609 Screw terminals with wire guards for light PVC wiring and max. 2 × 0.75 mm <sup>2</sup> or 1 × 2.5 mm <sup>2</sup>
Permissible vibrations:	2 g acc. to EN 60 068-2-6
Shock:	50 g 3 shocks each in 6 directions acc. to EN 60 068-2-27
Weight:	1 channel approx. 180 g 2 channels approx. 200 g

**Environmental conditions**

Climatic rating:	Climate class 3Z acc. to VDI/VDE 3540
Commissioning temperature:	– 10 to + 55 °C
Operating temperature:	– 25 to + 55 °C
Storage temperature:	– 40 to + 70 °C
Annual mean relative humidity:	≤ 75%

**Electrical insulation:**

All circuits (measuring inputs / meas-  
uring outputs / power supply) are  
electrically insulated

**Standards**

Electromagnetic compatibility:	The standards DIN EN 50 081-2 and DIN EN 50 082-2 are observed
Protection (acc. to IEC 529 resp. EN 60 529):	Housing IP 40 Terminals IP 20
Electrical standards:	Acc. to IEC 1010 resp. EN 61 010
Operating voltages:	< 300 V between all insulated circuits
Contamination level:	2



## Electrical connections

Front

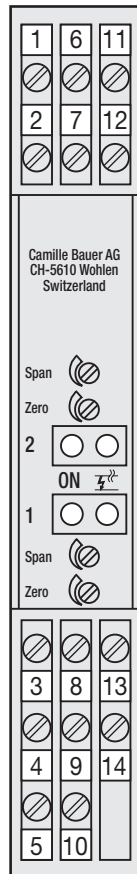

Without transparent cover

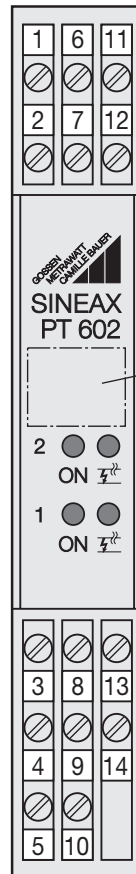

With transparent cover

Space e.g. for MSK designation

- ON  
Green LED's for indicating device standing by
- $\frac{1}{2}$   
Red LED's for indicating operation of open-circuit or short-circuit

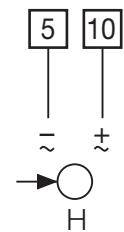
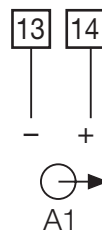
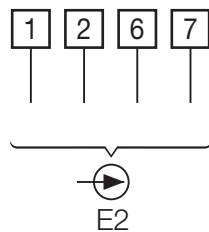
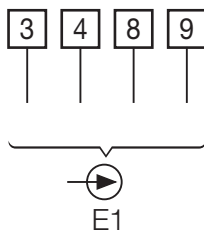

E1 = Measuring input 1 } Terminal allocation acc. to  
 E2 = Measuring input 2 } connection mode, see Table 5  
 A1 = Measuring output 1  
 A2 = Measuring output 2  
 H = Power supply

# SINEAX PT 602, 1 or 2 channels

## Configurable transmitter for Pt 100

Table 5: Connection of the measuring input leads E1 and E2

Measuring inputs		Connection mode*	Wiring diagram Terminal arrangement
Version with 1 input	Measuring input $\rightarrow$ E1	Two-wire connection	
		Three-wire connection	
		Four-wire connection	
Version with 2 inputs	Measuring input $\rightarrow$ E1	Two-wire connection	
		Three-wire connection	
		Four-wire connection	
	Measuring input $\rightarrow$ E2	Two-wire connection	
		Three-wire connection	
		Four-wire connection	

\* SINEAX PT 602 units with the type designations 602-1XX1 and 602-1XX2 can operate with either two or three-wire connections, but units with the type designation 602-1XX3 only operate with a four-wire connection.

## Dimensional drawings

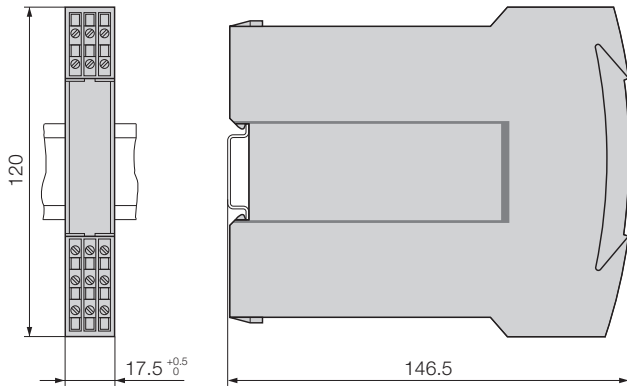

Fig. 3. SINEAX PT 602 in housing **S17** clipped onto a top-hat rail (35 × 15 mm or 35 × 7.5 mm, acc. to EN 50 022).

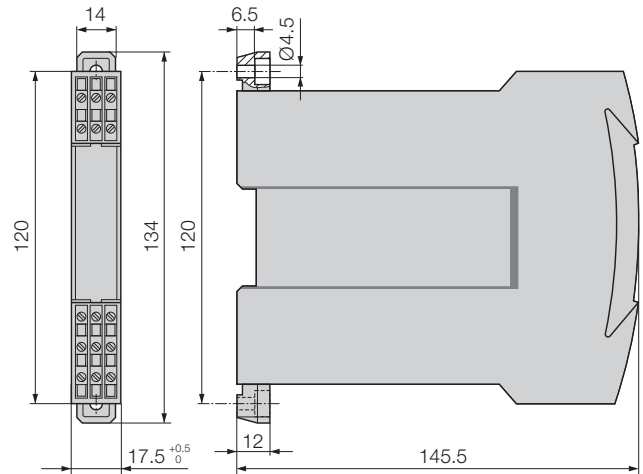

Fig. 4. SINEAX PT 602 in housing **S17** with the screw hole brackets pulled out for wall mounting.

## Standard accessories

- 1 Operating Instructions in three languages: German, French, English
- 2 Withdrawing handle (for opening the housing)
- 2 Labels (under transparent cover)

# **SINEAX PT 602, 1 or 2 channels**

## **Configurable transmitter for Pt 100**

---

---

Printed in Switzerland • Subject to change without notice • Edition 01.98 • Data sheet No. PT 602-1 Le

Camille Bauer Ltd

Aargauerstrasse 7  
CH-5610 Wohlen/Switzerland  
Phone +41 56 618 21 11  
Fax +41 56 618 24 58  
Telex 827 901 cbm ch

**GOSSEN  
METRAWATT  
CAMILLE BAUER**

