

Insulation fault evaluator

EDS460-DG

for localising insulation faults in DC IT systems with a number of branch circuits where high system leakage capacitances are involved





Insulation fault evaluators EDS460-DG

Device features

- Insulation fault location in IT systems
- For DC IT systems (20...308 V)
- Control and display function within one device
- 12 measuring channels (circuits) for measuring current transformers of the W, WR, WS series
- Up to 90 EDS evaluators in one system (1080 measuring channels)
- Scanning time max. 10 s for all measuring channels (parallel scanning)
- Response sensitivity 2...10 mA
- History memory to store 300 events
- Two alarm relays with one changeover contact each
- N/O or N/C operation, selectable
- Connection external test/reset button
- Indication via graphical display
- BMS address range 1...90
- Serial RS-485 interface
- Continuous CT connection monitoring
- Fault memory behaviour selectable
- Additional AC residual current measurement

Product description

EDS460-DG insulation fault evaluators are used in combination with the A-ISOMETER® IRDH575 or the PGH insulation fault test device to localise insulation faults in DC power supplies (IT systems). The test current signals generated by the insulation monitoring device IRDH575 or the insulation fault test device PGH are scanned by measuring current transformers and evaluated by the insulation fault evaluators. Up to 12 measuring current transformers can be connected to one EDS460-DG. If more than 12 branch circuits are to be monitored, up to 90 EDS evaluators can be connected via an RS-485 interface (BMS protocol), thereby 1080 branch circuits can be monitored. The maximum scanning time is approx. 4...10 s, see TGH1429. This device version is particularly suitable for systems involving high system leakage capacitances (20000 µFV, see characteristics in the chapter "Technical data").

Application

- Insulation fault location in DC IT systems
- DC main circuits in industrial installations and ships
- Diode-decoupled DC IT systems in power stations

Function

Insulation fault location is manually or automatically started via the IRDH575 A-ISOMETER® or the PGH. Once started, the insulation fault evaluator EDS simultaneously scans all measuring current transformers (channels). If several EDS exist, these devices are also scanned simultaneously.

When the test current detected by a measuring current transformer exceeds the set response value, the alarm LED 2 lights up, the common alarm relay switches and the faulty circuit is indicated as plain text on the graphical display. The connection between the measuring current transformer and the insulation fault evaluator is continuously monitored. In the event of wire interruption, the alarm LED 1 lights up and the alarm relay switches.

With the fault memory activated, the alarm messages of the individual channels remains stored until the reset button is pressed or until a reset command is given via the RS-485 interface. When the fault memory is deactivated, the alarm message remains stored until the insulation fault is eliminated.

History memory

The device utilises a history memory for failsafe storing of up to 300 measured values/ events (date, time, channel, event code, measured value), so that all data about an outgoing circuit or an area can be traced back at any time (what happened when).

AC residual current measurement

EDS evaluators can also be used for the indication of AC residual currents in unearthed power supplies (IT systems). This is essential when also AC residual currents are to be localised in the circuits. AC residual currents can be caused by charging rectifiers or converters connected to DC IT systems.

Device variants

EDS460-DG

Device version EDS460-DG features a backlit graphical display where information can be displayed in various ways. This version is applied when detailed information about all devices in the switchboard cabinet, connected to the bus, are to be displayed locally. This device is capable of assigning parameters to all devices connected to the BMS bus and displaying all measurement details. Several EDS460-DG devices can be used in one system.

Certifications



Overview of device types

Distinctive device features	EDS460-DG
Response value	EDS460: 2...10 mA
Residual current indication	EDS460: 20 mA...2 A
Backlit graphics LC display	×
Parameter setting function	×
Error code indication	×
Address range	1...90
Internal clock	×
History memory	×
Alarmkontakt "Common alarm" for all channels	2 x 1 changeover contact
Enclosure	XM460

Wiring diagram – operating elements EDS460-DG

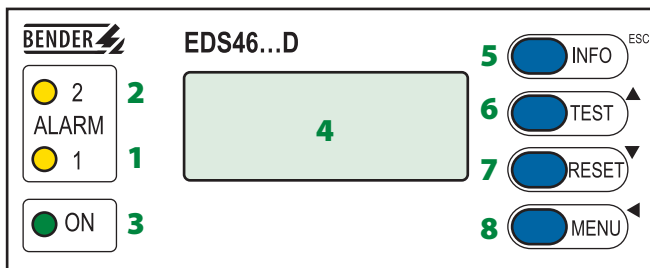

- 1 - Alarm LED 1 lights up in the event of the following system faults:
 - When the residual current is exceeded > 2 A (RCM function)
 - when there is a loss of power or short circuit in a measuring current transformer circuit (this function can be deactivated)
- 2 - Alarm LED 2 lights up when an insulation fault is detected on a channel (EDS function)
- 3 - Power On LED
- 4 - LC graphical display
- 5 - INFO key: To query standard information
ESC key: back to MENU function.
- 6 - TEST button: To call up the self test.
Arrow up key: Parameter change, scroll.
- 7 - RESET button: To acknowledge insulation and fault messages.
Arrow down key: Parameter change, scroll.
- 8 - MENU key: Toggles between the standard display, MENU and alarm display.
Enter key: To confirm parameter change.

Wiring diagram – system connection EDS460-DG

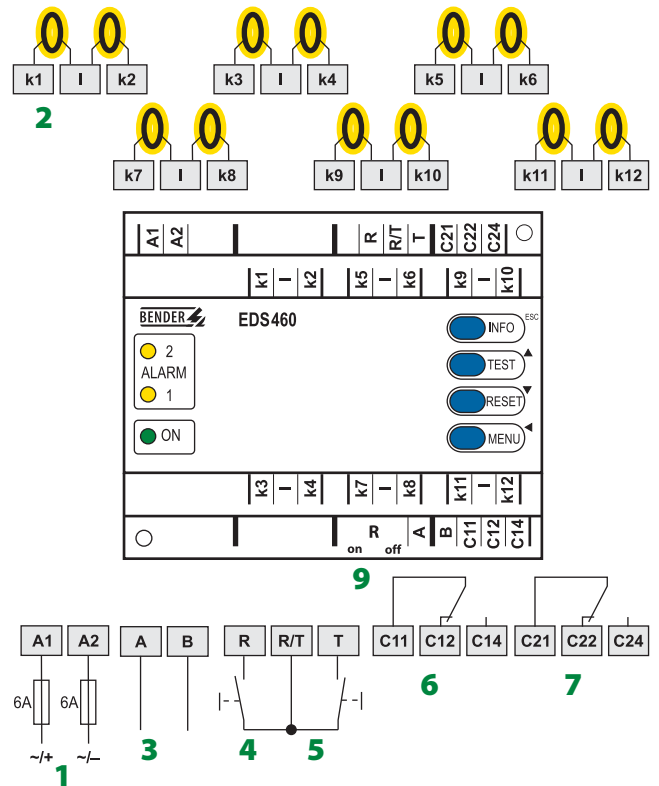

- 1 - Supply voltage U_s , see ordering information, 6 A fuse recommended. Two-pole fuses should be used on IT systems.
 - 2 - Connection measuring current transformers k1...k12
 - 3 - Serial interface RS-485
 - 4 - External RESET button (N/O contact)*
 - 5 - External TEST button (N/O contact)*
 - 6 - Alarm relay 1
 - 7 - Alarm relay 2
 - 8 - Alarm relay: One N/O contact per channel (EDS490/491 only)
 - 9 - $R_{on/off}$: Termination of the serial RS-485 interface (A/B) with 120 Ω
- * The external TEST/RESET buttons of several devices must not be connected to one another.

Example for system set-up

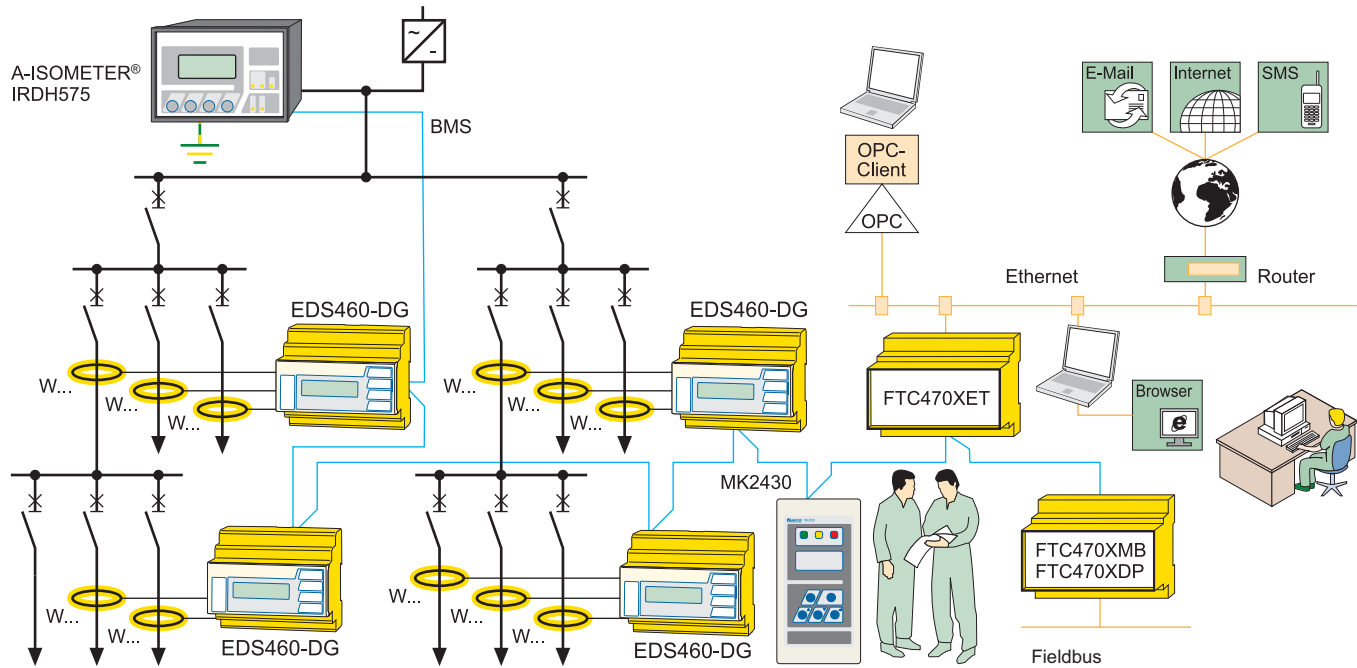

Example for system set-up

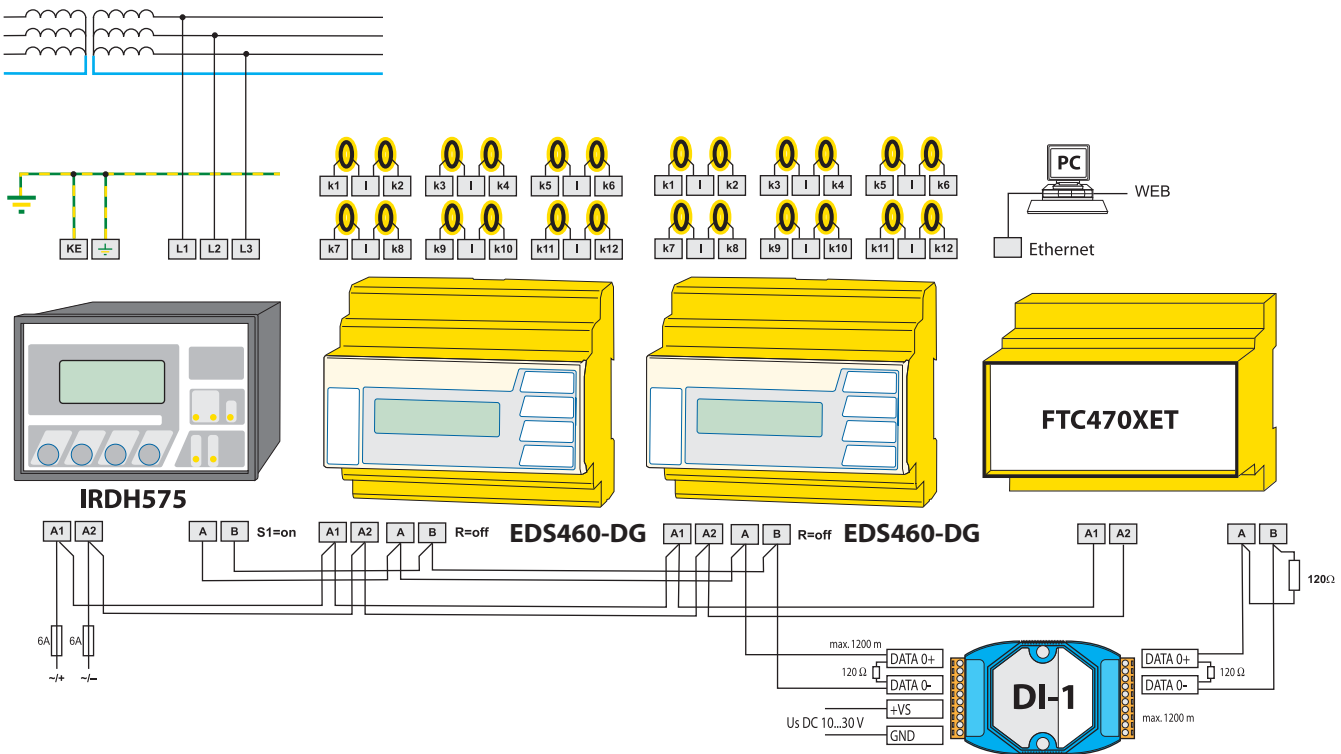

Note:
The DI-1 repeater only is required when the length of the cable exceeds 1200 m or when more than 32 devices are connected to the bus.

Technical data Insulation fault evaluator EDS460-DG
Insulation coordination acc. to IEC 60664-1

Rated insulation voltage	AC 250 V
Rated impulse voltage/pollution degree	4 kV / III
Protective separation (reinforced insulation) between (A1, A2) – (K1, L...K12, R/RT/T, AB) – (11, 12, 14) – (21, 22, 24)	
Voltage test according to IEC 61010-1	2.21 kV

Supply voltage

Supply voltage U_s	see ordering information
Frequency range	AC 42...460 Hz
Power consumption	≤ 10 VA

Measuring circuit

Nominal system voltage U_n	DC 20...308 V
Measuring current transformers, external type	W..., WR..., WS...
CT monitoring	on/off (on)*
Load	68 Ω
Rated insulation voltage (measuring current transformer)	800 V
Response sensitivity	2...10 mA (2 mA)*
Rated frequency	50/60/400 Hz
Measuring range EDS function	2...50 mA
Measuring range RCM function	20 mA...2 A
Number of measuring channels (per device/system)	12/1080

Specified time

Response delay t_{on}	0...24 s
Release delay t_{off}	0...24 s
Scanning time for all channels	approx. 4...10 s see TGH1429

EDS - measuring current transformer connection

Single wire $\geq 0.75 \text{ mm}^2$	0...1 m
Single wire, twisted $\geq 0.75 \text{ mm}^2$	1...10 m
Shielded cable $\geq 0.5 \text{ mm}^2$	10...40 m
Recommended cable (shielded, shield on one side connected to I-conductor, not connected to earth)	J-Y (ST) Y min. 2 x 0.8

Displays, memory

LEDs	ON/ALARM
LC display	backlit graphical display
History memory	300 data records
Password	off / 0...999 (off)*
Language	D, GB, F (GB)*
Fault memory alarm relay	on / off (off)*

Inputs/outputs

Test/reset button	internal/external
Cable length for external test/reset button	0...10 m

Interface

Interface/protocol	RS-485/BMS
Cable length	0...1200 m
Recommended cable (shielded, shield on one side connected to PE)	J-Y(ST)Y 2 x 0.8
Terminating resistor	120 Ω (0.25 W) via DIP switch connectable
Device address, BMS bus	DIP switch 1...90

Switching elements

Number	2 relays, each with 1 changeover contact				
Operating principle	NC / N/O operation (N/O operation)*				
Electrical service life, number of cycles	10.000				
Contact data acc. to IEC 60947-5-1					
Utilisation category	AC-13	AC-14	DC-12	DC-12	DC-12
Rated operational voltage	230 V	230 V	24 V	110 V	220 V
Rated operational current	5 A	3 A	1 A	0.2 A	0.1 A
Minimum contact load	1 mA at AC / DC 10 V				

EMC

EMC	IEC 61326
Operating temperature	-25°C...+55°C
Climatic class acc. to IEC 60721	
Stationary use (IEC 60721-3-3)	3K5 (except condensation and formation of ice)
Transport (IEC 60721-3-2)	2K3 (except condensation and formation of ice)
Long-time storage (IEC 60721-3-1)	1K4 (except condensation and formation of ice)
Classification of mechanical conditions IEC 60731	
Stationary use (IEC 60721-3-3) -3M4	
Transport (IEC 60721-3-2)	3M2
Long-time storage (IEC 60721-3-2)	1M3

Connection

Connection type	push-wire terminals
Connection properties:rigid/flexible	0.2...2.5 mm ² (AWG 24...14)
Flexible with ferrule	0.2...1.5 mm ² (AWG 24...16)
Stripping length	10 mm
Opening force	50 N
Test opening, diameter	2.1 mm

General data

Operating mode	continuous operation
Position of normal use	any
Degree of protection, terminals (IEC 60529)	IP 20
Enclosure material	polycarbonate
Flammability class	UL94V-0
Screw mounting	2 x M4
DIN rail mounting acc. to	IEC 60715
Product standards	DIN EN 61557-9: 2000-08 EN 61557-9: 1999-11, IEC 61557-9: 1999-09
Operating manual	TGH1429
Weight	≤ 360 g

() * factory setting

Response sensitivity in relation to the system capacitance

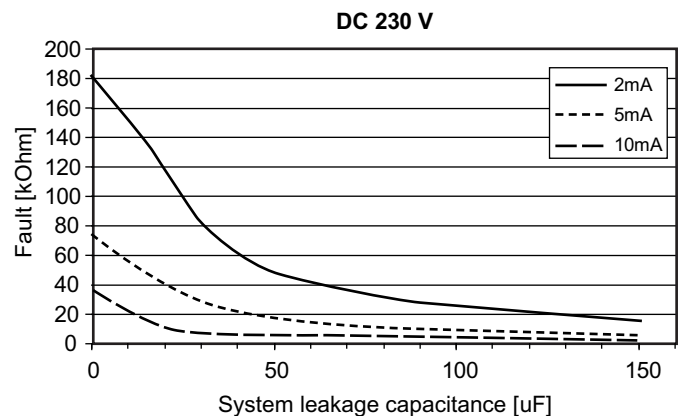
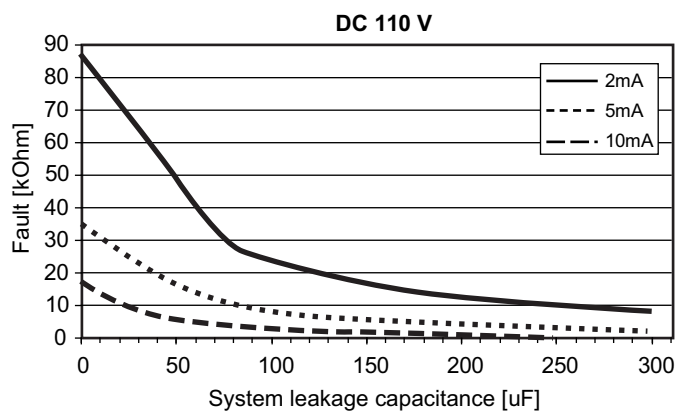

Explanatory notes on the response sensitivity

The value of the maximum response sensitivity decreases in relation to the system leakage capacitance. The EDS460 DG reaches the following maximum response values:

100 Ω/V at max. 20000 μFV system voltage (product of the system voltage and system leakage capacitance)

Example: System voltage 230 V

20000 μFV / 230V = 87 μF

230 V x 100 Ω/V = 23 k Ω minimum response value at 87 μF system leakage capacitance

Ordering information

Type	Supply voltage U_S^*	Response value	Art. No.
EDS460-DG-1	AC 42...460 Hz 16...72 V / DC 16...94 V	2...10 mA	B 7108 0018
EDS460-DG-2	AC/DC 70...276 V, AC 42...460 Hz	2...10 mA	B 7108 0019

These devices can also be delivered with screw-type terminals

*Absolute values

Dimension diagrams XM460

Dimensions are given in mm

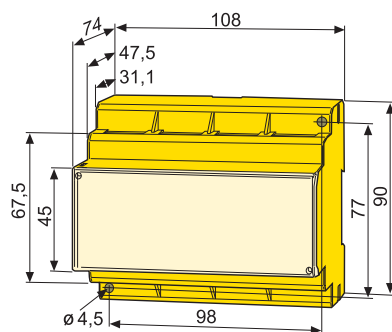

Dipl.-Ing. W. Bender GmbH & Co KG

Postfach 1161 • 35301 Grünberg • Germany

Londorfer Straße 65 • 35305 Grünberg • Germany

Tel.: +49 6401 807-0 • Fax: +49 6401 807-259

E-Mail: info@bender-de.com • www.bender-de.com

Power in electrical safety