

RM475

RM475LY

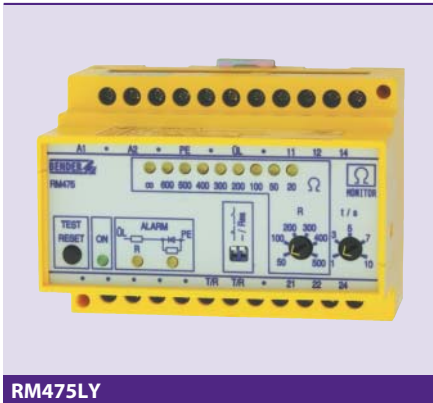

RM475LY

Device features

- RM475 – permanently set response value
Series resistance 200 Ω
Cross resistance 1000 Ω
- RM475LY
Series resistance, adjustable 50...500 Ω
Cross resistance 1000 Ω
- Adjustable response delay 1...10 s (RM475LY)
- N/O or N/C operation, selectable
- Fault memory behaviour selectable
- Internal/external TEST/RESET button
- LEDs: Power On LED, alarm LEDs
- LED bar graph for series resistance
- 2 potential-free changeover contacts
- Modular DIN rail enclosure

Product description

The devices of the RM475 series in conjunction with a terminating device are designed to monitor a closed and voltage-free loop for interruption (series resistance) and for short-circuit (cross resistance). The RM475 version has a continuously set response value for series and cross resistance. The response time is max. 1 s.

The response value for the series resistance of device version RM475LY can be adjusted between 50...500 Ω . The response value for the cross resistance for this version, however, is continuously set, too. The response time can be set between 1...10 s.

Application

- Monitoring of conductors and cables by means of a monitoring conductor
- Monitoring of PE loops

Function

The conductor loop to be monitored is connected to the terminals ÜL and PE. A terminating device closes the conductor loop (EV22S). A measuring voltage is superimposed on the conductor loop. When the series or cross resistance exceeds the response value, the alarm relay switches and the alarm LEDs light up after the response delay t_d has elapsed. The alarm LEDs even lights when the connection ÜL/PE (connection terminating resistor) is open when supply voltage is applied. If extraneous voltage occurs on the measuring circuit, e.g. in the case of an open circuit, z.B. (PE interrupted) the alarm LED lights as well and the alarm relay switches.

Wiring diagram

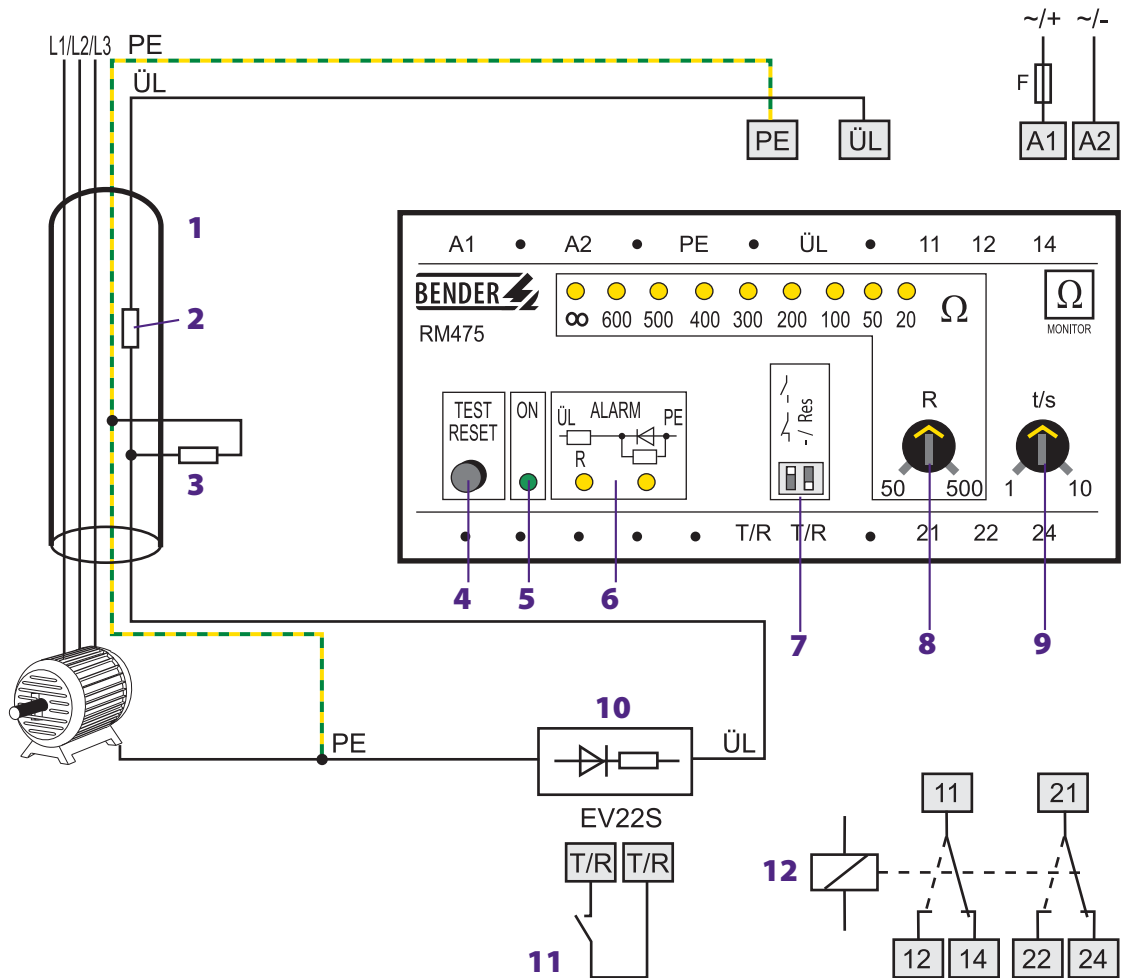

- 1 - Conductor
- 2 - Series resistance
- 3 - Cross resistance
- 4 - TEST/RESET button
- 5 - Power On LED "ON"
- 6 - Alarm LED, lights when series or cross resistance errors occur and flashes in case of extraneous voltage
- 7 - DIP switch for setting the operating principle
 - N/C or N/O operation
 - Fault memory behaviour ON/OFF
- 8 - Adjustable response value "R" series resistance 50...500 Ω (RM475LY only)
- 9 - Adjustable time delay "t/s" 1...10 s (RM475LY only)
- 10 - Terminating device
- 11 - External test/reset button "T/R"
- 12 - Alarm relay:
 - N/C operation
 - - - N/O operation
- F - Short-circuit protection supply voltage
6 A fuse is recommended

3.6

Technical data loop monitor RM475 / RM475LY

Insulation coordination acc. to IEC 60664-1

Rated insulation voltage	AC 250 V
Rated impulse voltage/pollution degree	4 kV/3

Supply voltage

Supply voltage U_S	see ordering information
Operating range U_S	0.85...1.1 x U_S
Power consumption	≤ 3 VA

Measuring circuit

RM475

Response value series resistance	200 Ω
Response value cross resistance	1000 Ω
Response time t_{an}	< 1 s

RM475LY

Response value series resistance	50...500 Ω (200 Ω)*
Response value cross resistance	1000 Ω
Response time t_V	1...10 s
Max. extraneous voltage measuring circuit	≤ AC 30 V
Terminating resistor conductor loop EV22S	AC 500 V 1 s

Switching elements

Number of changeover contacts	1 x 2
Operating principle	N/C operation or N/O operation (N/O operation)*
Fault memory behaviour selectable	ON/OFF
Electrical service life, number of cycles	12000
Contact class IEC 60255 Part 0-20	IIB
Rated contact voltage	AC 250 V/DC 300 V
Limited making capacity	AC/DC 5 A
Breaking capacity	2 A, AC 230 V, cos phi 0.4 0.2 A, DC 220 V, L/R = 0.04 s

Environment / EMC

EMC immunity	acc. to IEC 61000-6-2
EMC emission	acc. to IEC 61000-6-4
Shock resistance IEC 60068-2-27 (during operation)	15 g/11 ms
Bumping IEC 60068-2-29 (during transport)	40 g/6 ms
Vibration resistance IEC 60068-2-6 (during operation)	1 g / 10...150 Hz
Vibration resistance IEC 60068-2-6 (during transport)	2 g / 10...150 Hz
Ambient temperature, during operation	-10...+55 °C
Ambient temperature (storage)	-40...+70 °C
Climatic class acc. to IEC 60721-3-3	3K5 (except condensation and formation of ice)

Other

Operating mode	continuous operation
Mounting	any position
Connection	screw terminals
Connection properties	
single wire	0.2...4 mm ²
flexible	0.25...2.5 mm ²
Degree of protection, internal components (IEC 60529)	IP30
Degree of protection, terminals (IEC 60529)	IP20
Screw fixing	2 x M4
DIN rail mounting acc. to	IEC 60715
Flammability class	UL94V-0
Operating manual	BP702001
Weight	≤ 400 g

() * factory setting

Ordering information

Type	Supply voltage U_S	Art. No.
RM475	AC 50...60 Hz 230 V	B 9702 2001
RM475-13	AC 50...60 Hz 90...132 V	B 9702 2002
RM475-15	AC 50...60 Hz 400 V	B 9702 2003
RM475-16	AC 50...60 Hz 500 V	B 9702 2004
RM475-21	DC 9.8...84 V	B 9702 2005
RM475-23	DC 77...286 V	B 9702 2006
RM475LY	AC 50...60 Hz 230 V	B 9702 2007
RM475LY-13	AC 50...60 Hz 90...132 V	B 9702 2008
RM475LY-15	AC 50...60 Hz 400 V	B 9702 2009
RM475LY-16	AC 50...60 Hz 500 V	B 9702 2010
RM475LY-21	DC 9.8...84 V	B 9702 2011
RM475LY-23	DC 77...286 V	B 9702 2012
EV22S	terminating device	B 984 800

Dimension diagram X470

Dimensions in mm

