

830 Loop-Powered Process Indicator

830 R
Process Indicator



830 S1
Process Indicator



830 S2
Process Indicator



The 830 loop-powered digital indicators are universally applicable. The range (either 0 - 20 mA or 4 - 20 mA) is simply selected via terminals. Display starts working at an operating current of only 0.3 mA. The low voltage drop of 0.5 V allows application in current loops with low load voltage.

Bargraph for quick range overview

The digital indicators provide a bargraph in addition to the digital display. This gives you all information on your process variable at a single glance.

Versatile setting capabilities

Zero, span and min/max outputs can be adjusted as desired, enabling direct readout of measured values such as temperature, power, displacement, pH value etc. The indicator comes with a symbol set for standard engineering units. The symbols can easily be replaced. Thanks to microprocessor technology, you do not require a high-precision external reference current for parameter setting. Even during operation, the settings can be changed without problems.

Loop-powered. Your advantage.

The digital indicators are simply inserted into the current loop like passive analog indicators.

Since power supplies and their wiring are not required, costs could decisively be reduced, allowing for displays which have been too expensive before.

In addition, the reliability has considerably been improved since a power failure in the control room does not interrupt the data flow. And, in contrast to conventional digital indicators, there is no coupling between measuring loop and power supply.

Construction

The product line includes indicators in modular cases, as well as large and small cases for installation in equipment and control panels.

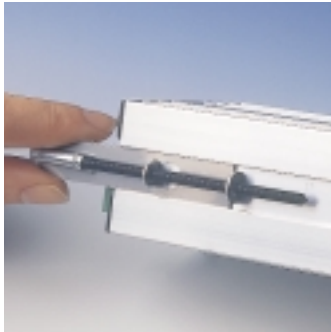

Easy installation in the control panel

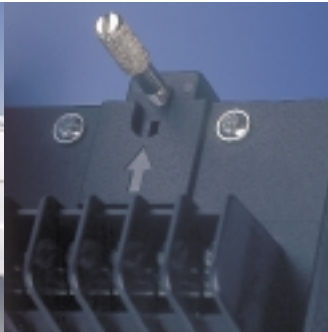

Easy handling with only four pushbuttons



Convenient plug-in terminals make mounting easy

Floating min/max outputs on request

The two optionally available min/max outputs can be set as normally closed or normally open contacts. Limit values, hysteresis and switch-on delay can be set as desired.

EMC to NAMUR*

EMC design ensures reliable measurements even under unfavorable ambient conditions.

HART® communication

The indicators transmit HART® signals disturbance-free. Measured value display is not affected.

* German committee for measurement and control standards in the chemical industry

The facts:

- Digital indication without power supplies and supply leads
- No signal interference due to power supply coupling
- Power failure without effect on indication
- No parasitic voltages
- Universal range selection
- Exchangeable unit symbols
- Adjustable, floating min/max outputs, optional
- IP 65
- Large 23 mm characters, 4-digit display
Span up to 10,000 counts
Display range
–9,999 to +9,999
- Range overview by integrated bargraph
- Voltage drop <0.5 V
- Settings user defined without external reference current
- Change of settings also during operation
- Settings protected by passcode
- For use in HART® circuits

Warranty

Defects occurring within 3 years from delivery date shall be remedied free of charge at our works (carriage and insurance paid by sender).

Accessories: 1 year

Product line

Instrument		Ref. No.
830 R Process Indicator	Loop-powered indicator in modular case with standard symbol set	830 R
830 S1 Process Indicator	Loop-powered indicator in panel-mount case (96 x 48 mm) with standard symbol set	830 S1
830 S2 Process Indicator	Loop-powered indicator in panel-mount case (144 x 72 mm) with standard symbol set	830 S2
Options		
Additional Pg cable gland	For version R as branching box	119
Outputs	Versions S1 and S2 with two min/max outputs, (60 V DC, 350 mA)	290
Range selection	Range fixed according to customer requirements	365
Accessories		
Symbol	Other unit symbol (not standard symbol set)	ZU 0129
Pipe mount kit	Pipe mount kit (only version R)	ZU 0154

Standard symbol set

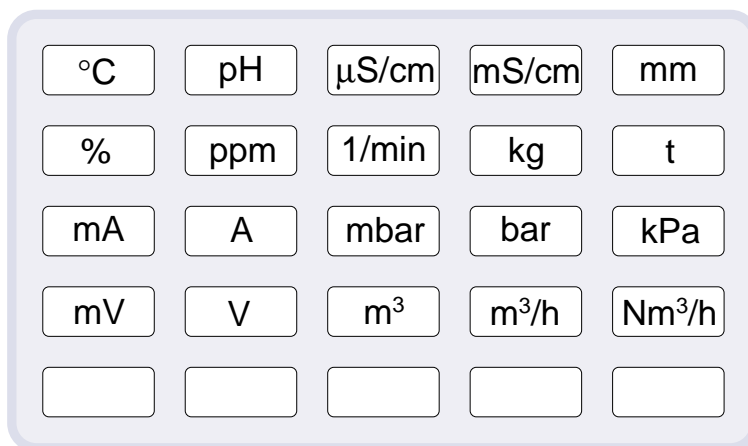

Specifications

Input	4 to 20 mA, voltage drop approx. 0.5 V 0.3 to 20 mA, voltage drop approx. 3.2 V
Display	LCD: character height 23 mm (R, S2), 16 mm (S1) 4-digit measured value display, sign, 3 decimal points Function indicators: par, 0 mA, 4 mA, 20 mA, min, max, hyst, s, n/c, n/o, adj, bargraph limits Bargraph with 2 % resolution, height approx. 3.5 mm (R, S2), approx. 2.5 mm (S1)
Display range	-9,999 to +9,999
Range selection	Span up to 10,000 counts, displacement up to $\pm 9,999$ counts Bargraph user defined within span Rising/falling characteristic
Keypad	4 buttons par, ▲ span, ► mA, ent par: Activate parameter mode ▲ span: In parameter mode: select submenu, count up selected digit, In measuring mode: alternately display start/end of scale ► mA: In parameter mode: select digit, In measuring mode: display loop current ent: Confirm entered value
Decimal point	User defined, without, P1, P2, P3
Measuring rate	1/s
Accuracy	<0.1 % of measured value ± 2 counts
Temperature coefficient	<0.01 % of span/K ± 0.1 count/K (average over permissible temperature range)
Overload capacity	± 150 mA
Min/Max outputs	Floating solid-state switches (min and max), 60 V DC, 350 mA Voltage drop when switched approx. 0.5 V, With input currents <0.3 mA (<3.8 mA) or >approx. 24 mA the solid-state switches block Hysteresis: 0 to 9,999 counts, user defined Switch-on delay: 0 to 9,999 s, user defined Contact type: normally closed (n/c) or normally open (n/o), user definable Separate indication of switching state on display Display flashing can be turned off
Symbols	Set of 20 symbols and five blank labels included

Specifications

Terminals	For version R, two wires can be connected to one terminal (Opt. 119) Stranded wire: up to 1.5 mm ² Single wire: up to 2.5 mm ² (S1, S2), up to 1.5 mm ² (R)
Data retention	Parameters and calibration data > 10 years (EEPROM)
Product family standard	EN 61326-1, EN 61326/A1
Generic standards	EN 50081-1, EN 50081-2, EN 50082-1, EN 50082-2
EMC	Accuracy during disturbance < 1 % span

	830 R	830 S1	830 S2
Ambient temperature			
Operation:	-25 to +65 °C	-10 to +65 °C	
Storage:	-30 to +70 °C	-20 to +70 °C	
Adjustments	Internal	Front panel	
Min/max outputs	No	Yes (Option 290)	
Enclosure	Version R: modular	Version S1: panel	Version S2: panel
Material	Al Si 12, DIN 1725, with glass pane, Insert made of Byblend, Rating plate: polyester	Front panel overlay: polyester, with window Front: PA + GF, sides: Al Rear: PA + GF	Front panel overlay: polyester, with glass pane, Front and sides: PA + GF, Rear: PA + GF
Color	Lid: iron gray RAL 7011, Bottom: gray RAL 7001, Insert: black	Front: iron gray RAL 7011, Sides: Al, Rear: black Buttons: black	Front: iron gray RAL 7011, Sides and rear: black Buttons: black
Dimensions in mm (incl. terminals and Pg cable glands)	W 200 x H 80 x D 57	W 96 x H 48 x D 118	W 144 x H 72 x D 57
Protection (EN 60529)	IP65		
Front to control panel:		IP65	
Rear:		IP20	
Weight	Approx. 750 g	Approx. 300 g	Approx. 300 g

Typical applications

Application with 4-wire transmitter

Different design versions allow to install the indicators on the site and/or in the control panel

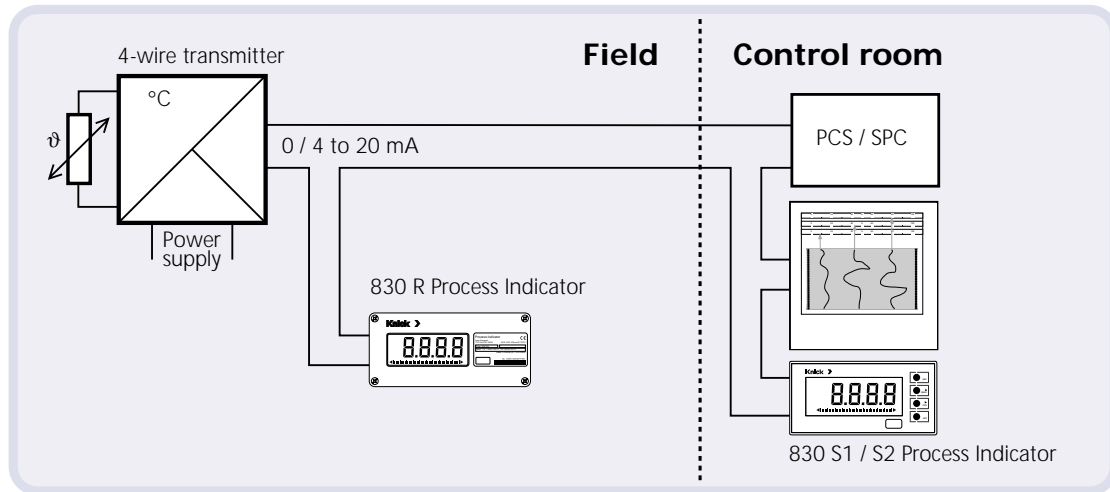

Application with 2-wire transmitter and power supply / mains adapter

Different design versions allow to install the indicators on the site and/or in the control panel

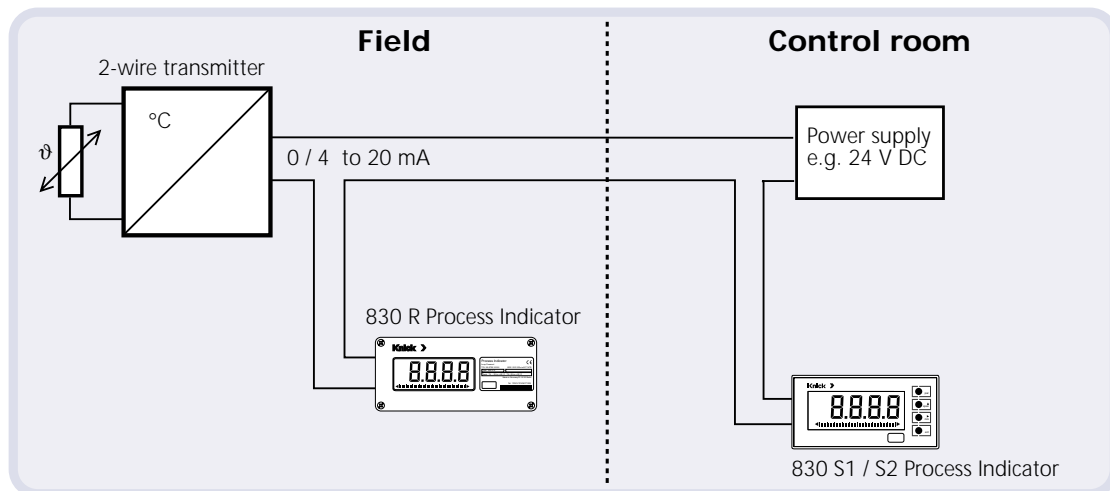

Typical applications

Application with 2-wire transmitter and repeater power supply

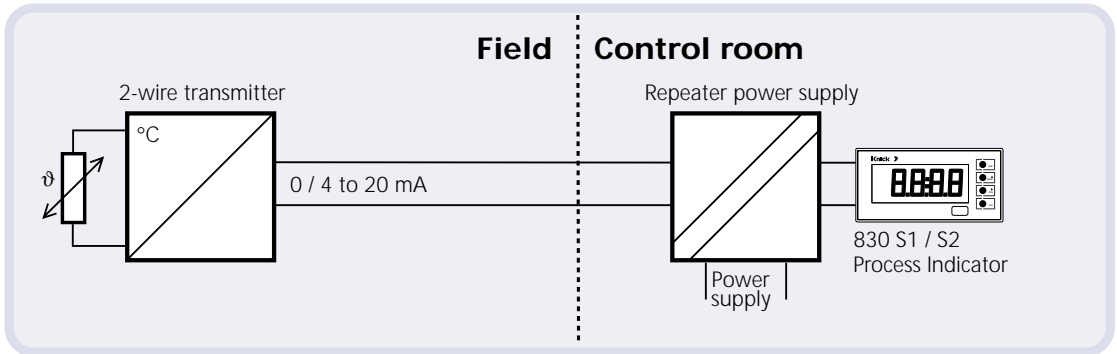

Dimension drawings

830 R Process Indicator

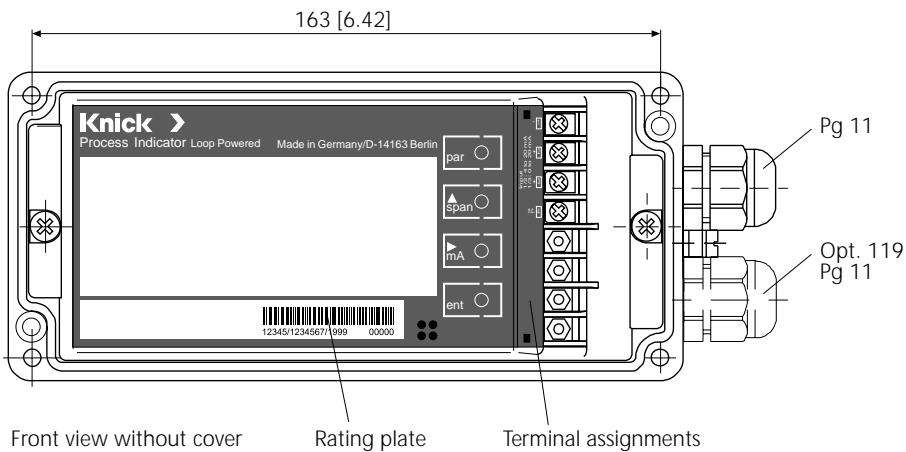
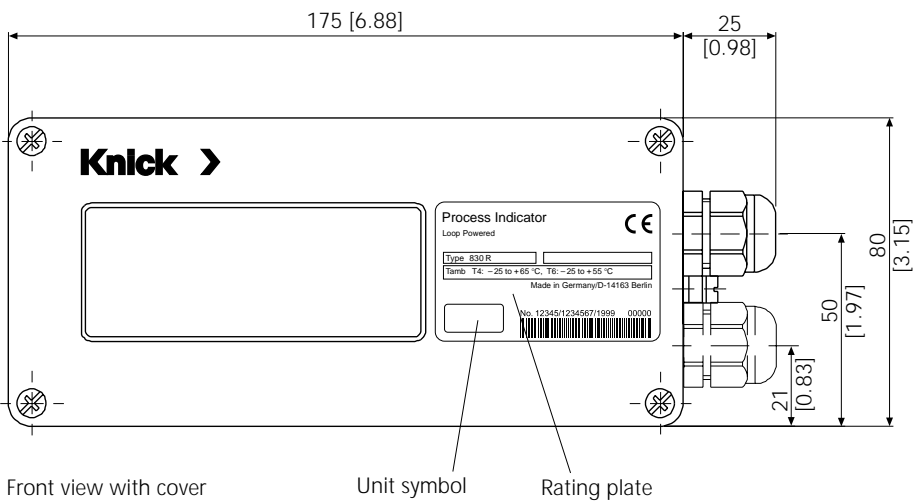
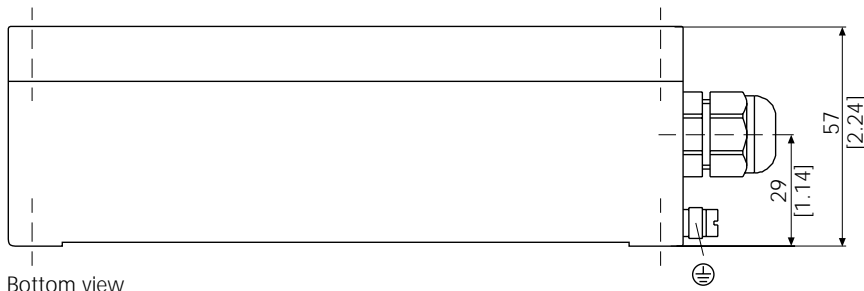

Note: All dimensions in mm [in]

Dimension drawings

830 R Process Indicator

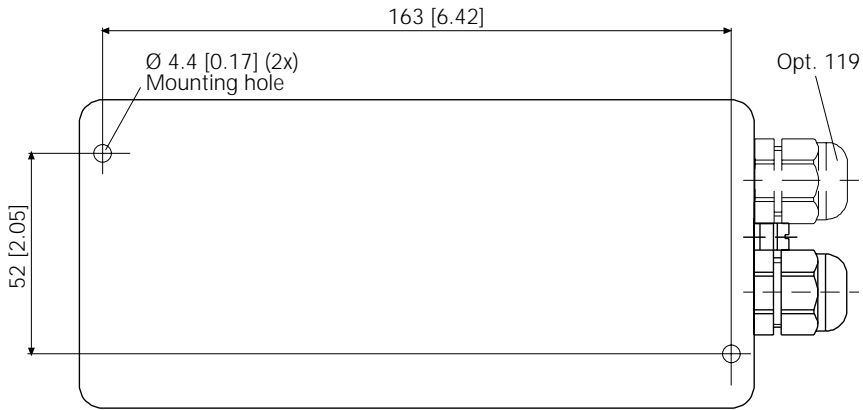

Rear view

Note: All dimensions in mm [in]



Keypad

Dimension drawings

ZU 0154 Pipe mount kit for 830 R Process Indicator

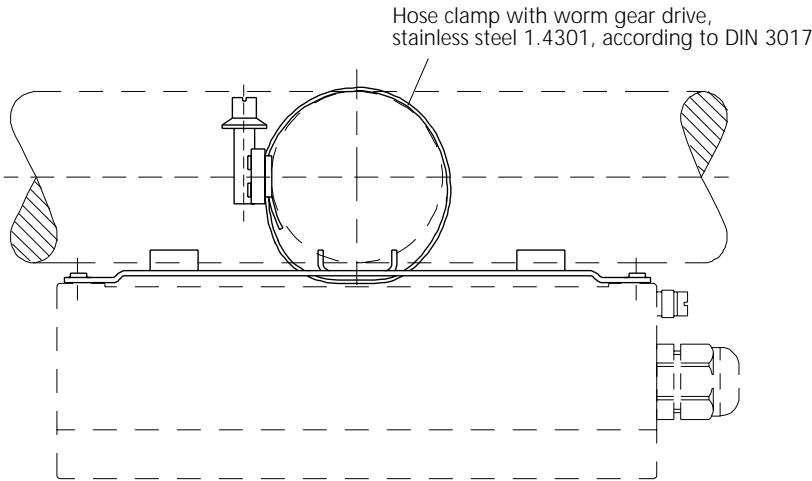
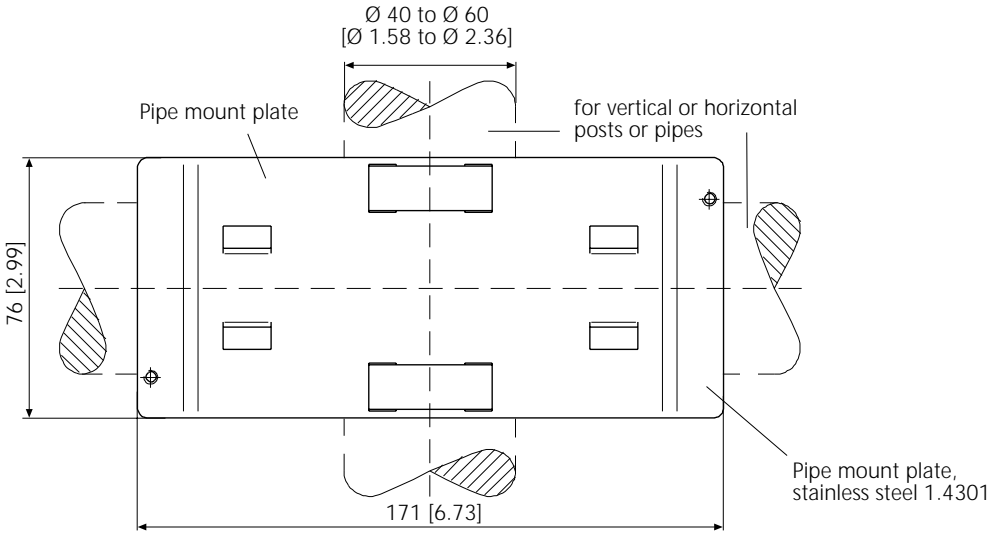

Note: All dimensions in mm [in]

Dimension drawings

830 S1 Process Indicator

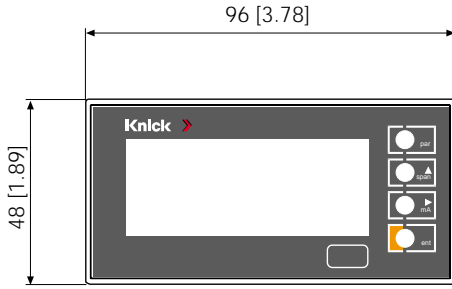

Front view

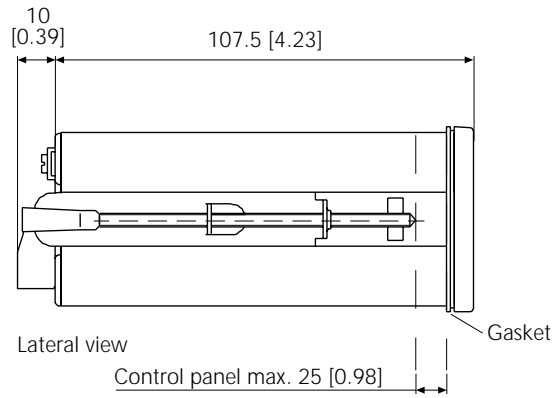

Lateral view

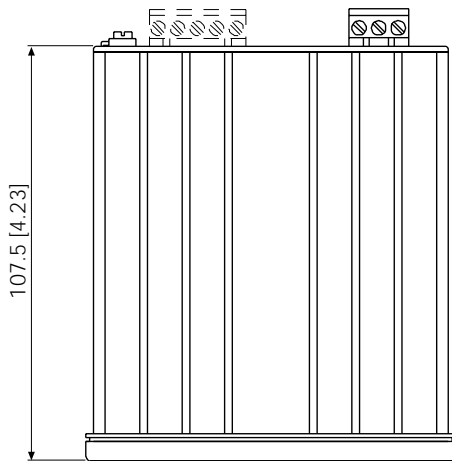

Top view

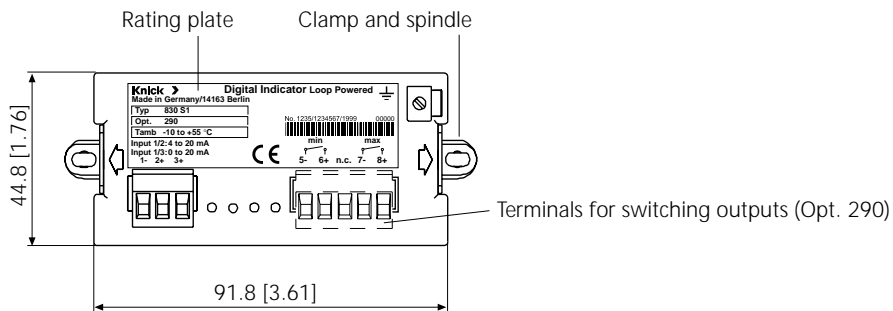

Rear view

Note: All dimensions in mm [in]

Dimension drawings

830 S2 Process Indicator

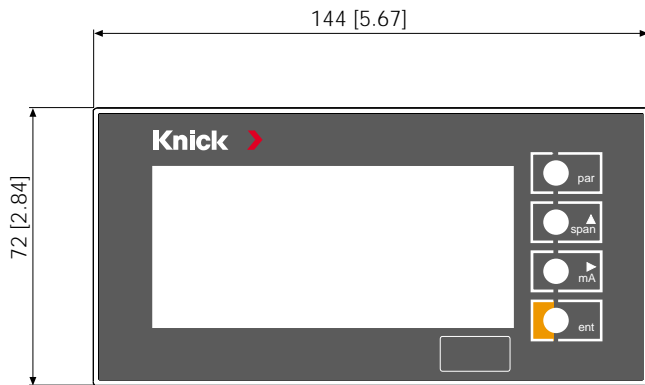

Front view

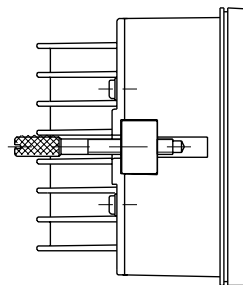

Lateral view

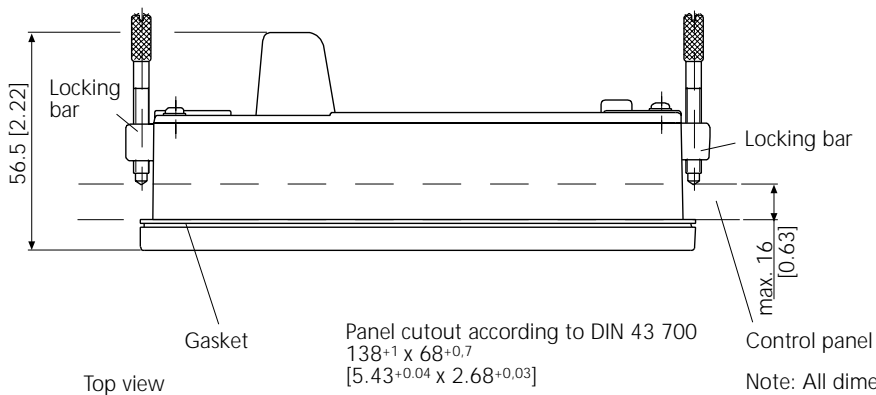

Top view

Note: All dimensions in mm [in]

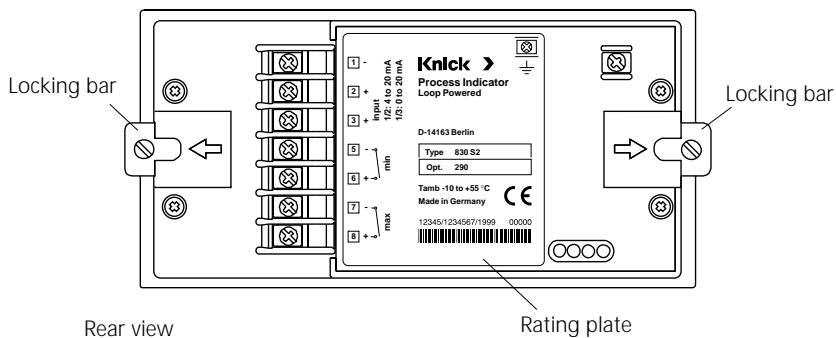

Rear view

Rating plate

