

## 1. Safety instructions

### 1.1 Symbols

The symbols in these instructions point out risks and have the following meaning:



Warning in case of risks.  
Non-observance can result in malfunctioning.



Non-observance can result in malfunctioning and personal injury.



Information on proper product handling.

### 1.2 Intended use

- The KINAX 2W2 is a precision instrument. It is used to determine angular positions, processing and providing measured values of electrical output signals for the downstream device. Encoders use for this purpose only.
- The angular position transmitter is not intended to measure rotation speed.
- The device is intended for installation in industrial plants and meets the requirements of EN 61010-1.
- Device versions with explosion protection may only be used in the planned purposes and have to be installed in a housing with an ingress protection of at least IP20 according to EN 60529. The operation in other explosive atmospheres is not permissible.
- Manufacturer is not liable for any damage caused by inappropriate handling, modification or any application not according to the intended purpose.

### 1.3 Commissioning



- Installation, assembly, setup and commissioning of the device has to be carried out exclusively by skilled workers.
- Observe manufacturer's operating instructions.
- Check all electric connections prior to commissioning the plant.
- If assembly, electric connection or other work on the device and the plant are not carried out properly, this may result in malfunctioning or breakdown of the device.
- Safety measures should be taken to avoid any danger to persons, any damage of the plant and any damage of the equipment due to breakdown or malfunctioning of the device.
- Do not operate the device outside of the limit values stated in the operating instructions.
- Operation of device versions with explosion protection is only permissible when...
  - the details on the type label of the device match the on-site conditions for the permissible Ex area in use (group of equipment, equipment category, zone, temperature class or maximum surface temperature)
  - the details on the type label of the device match the electrical supply network
  - the device is undamaged and
  - it has been checked that there is no explosive atmosphere, oils, acids, gases, vapors, radiation etc. present during installation.

### 1.4 Repair work and modifications



Repair work and modifications shall exclusively be carried out by the manufacturer. In case of any tampering with the device, the guaranty claim shall lapse. We reserve the right of changing the product to improve it.

### 1.5 Disposal



The disposal of devices and components may only be realised in accordance with good professional practice observing the country-specific regulations.

### 1.6 Transport and storage



Transport and store the devices exclusively in their original packaging. Do not drop devices or expose them to substantial shocks.

## Operating Instructions



Camille Bauer Metrawatt AG  
Aargauerstrasse 7  
CH-5610 Wohlen/Switzerland  
Telefon +41 56 618 21 11  
Telefax +41 56 618 21 21  
info@camillebauer.com  
www.camillebauer.com

## Programmable Transmitter for angular position KINAX 2W2



2W2 Be 149 973-05 06.15

## 2. Scope of delivery

- Transmitter for angular position KINAX 2W2, acc. made to order
- 3 clamps
- 1 Operating instructions in German, French and English
- 1 Type examination certificate, only with ATEX-approval

## 3. Application

The KINAX 2W2 transmitter converts the angular position of a shaft into a **load independent** direct current signal, proportional to the angular position.

Due to the compact design, the angular position transmitters are particularly suitable for installation in or mounting / on devices and apparatuses.

Explosion-proof "Intrinsically safe Ex ia IIC T6" versions with I.S. measuring output rounds off this series of transmitters.

## 4. Main features

- Compact angular position transmitters for installation or mounting
- Capacitive scanning system
- 4...20mA analog output signal with 2-wire connection
- Drive shaft without stops, rotating
- Low starting torque < 0.001 Nm
- Non-wearing and low-maintenance
- Adjustment / Independent fine adjustment of the analog output, zero position and measuring range
- Characteristic of the output value / Programmable as a linear, V-characteristic, or any characteristic curve
- With explosion prevention „Ex ia IIC T6 Gb“ according to ATEX available

## 5. Technical data

### 5.1 Measuring input

Measuring ranges: Programmable between 0 to 50° or 0 to 350°  
Shaft-diameter: 2 mm, 6 mm [0.078", 0.236"] and 1/4"  
Starting torque: < 0.001 Ncm [0.0014 oz-in] at 2 mm [0.078"] shaft  
< 0.03 Ncm [0.0425 oz-in] at 6 mm [0.236"] resp. 1/4" shaft programmable

Direction of rotation:

### 5.2 Measuring output

Output variable  $I_A$ : Load-independent DC current, proportional to the input angle

Standard ranges: 4...20 mA, 2-wire connection

DC voltage: Standard (Non-Ex):  
Input voltage  $U_i$ : 12...33 V

Explosion protection intrinsic ia:  
Input voltage  $U_i$ : 12...30 V  
max. input current  $I_i$ : 160 mA  
max. input power  $P_i$ : 1 W  
max. internal capacitance  $C_i$ : 6.6 nF  
max. internal inductance  $L_i$ : is negligible

Max. residual ripple: 0.3 % p.p.  
Setting time: < 5 ms

External resistance:  $R_{ext. max.} [k\Omega] = \frac{H [V] - 12 V}{I_A [mA]}$

$H$  = Power supply  
 $I_A$  = Output signal end value

### 5.3 Accuracy

Reference value: Measuring range  
Basic accuracy: 0.5 % with linear characteristic

Calculation additional error:

Output characteristic	Definition	Additional error
<p>Linear</p>	<p>Programmable Angle max = MW Angle min = 0°</p> <p><math>[f_{Add}] = \%</math></p> <p>e.g. at MW=180°: <math>f = f_{add} + f_{Abs} = 0,05\% + 0,5\% = 0,55\%</math></p>	<p>Device type 350°: <math>f_{Add} = \left( \frac{0,18^\circ}{MS} \times 100 - 0,05 \right)</math></p> <p>Device type 50°: <math>f_{Add} = \left( \frac{0,05^\circ}{MS} \times 100 - 0,05 \right)</math></p>
<p>simple V-characteristic</p>	<p>Programmable Angle max = MW Angle min = 0°</p> <p><math>[f_{Add}] = \%</math></p>	<p>Device type 350°: <math>f_{Add} = \left( \frac{0,18^\circ}{MS} \times 100 \right)</math></p> <p>Device type 50°: <math>f_{Add} = \left( \frac{0,05^\circ}{MS} \times 100 \right)</math></p>
<p>Offset V-characteristic</p>	<p>MS=(angle max.)-(angle min.) Angle max = ± final angle Angle min. = &gt; 0°</p> <p><math>[f_{Add}] = \%</math></p>	<p>Device type 350°: <math>f_{Add} = \left( \frac{0,25^\circ}{MS} \times 100 \right)</math></p> <p>Device type 50°: <math>f_{Add} = \left( \frac{0,09^\circ}{MS} \times 100 \right)</math></p>
<p>Beliebige Kennlinie</p>	<p>MS=(angle max.)-(angle min.)</p> <p><math>[f_{Add}] = \%</math></p>	<p>Device type 350°: <math>f_{Add} = \left( \frac{0,25^\circ}{MS} \times 100 \right)</math></p> <p>Device type 50°: <math>f_{Add} = \left( \frac{0,09^\circ}{MS} \times 100 \right)</math></p>

Reproducibility: < 0,2 %  
 Influence of temperature (-40 ... +75 °C) [-40 ... +167 °F]: ± 0,2 % / 10 K

**5.4 Installation Data**

Material: Housing: Metal (aluminium), Surface chromated Alodine 400  
 Mounting position: Any

Sense	Drive shafts dia.	
	2 mm	6 mm resp. 1/4"
radial max.	16 N	83 N
axial max.	25 N	130 N

**5.5 Regulations**

Spurious radiation: En 61000-6-3  
 Immunity: EN 61000-6-2  
 Common-mode voltage: 100 V AC, CATII  
 Test voltage: 750 V DC, 1 min. all electrical connections against housing  
 Housing protection: IP 50 acc. to EN 60529

**5.6 Environmental conditions**

Climatic rating: Standard version  
 Temperature - 25 to + 75 °C [-13...+167 °F]  
 Annual mean relative humidity ≤ 90 % or  
Version with improved climatic rating  
 Temperature - 40 to + 75 °C [-40...+167 °F]  
 Annual mean relative humidity ≤ 95 %  
Ex version

Maximum Power	Temperature class			
	Pi	T6	T5	T4
1000 mW	40°C [104°F]	55°C [131°F]	75°C [167°F]	
900 mW	44°C [111.2°F]	59°C [138.2°F]	75°C [167°F]	
800 mW	49°C [120.2°F]	64°C [147.2°F]	75°C [167°F]	
700 mW	54°C [129.2°F]	69°C [156.2°F]	75°C [167°F]	
660 mW	56°C [132.8°F]	71°C [159.8°F]	75°C [167°F]	

The min. permissible ambient temperature is -40 degrees. 2000 m max.

Altitude: 2000 m max.  
 Transportation and storage temperature: -40 to 80 °C [-40...+176 °F]  
 Vibration resistance: 5 g per 2h in 3 directions  
 Shock resistance: 3x50 g per 10 splicing in all directions

**5.7 Operation in potentially explosive environments:**

Gas explosion prevention: Labeling: Ex ia IIC T6 Gb  
 Conform to standard: ATEX: EN 60079-0:2012 EN 60079-11:2012  
 Type of protection: ia  
 Temperature class: T6  
 Group according to EN 60079-00:2012: II

- The operation in other explosive atmospheres is not permissible.
- It is not permissible to make any alteration to equipment that is used in potentially explosive environments.



Devices with explosion prevention must be operated in accordance with the stipulations of the operating instructions. The relevant laws, regulations and standards for the planned application must be observed.

**5.8 Dimensional drawing**

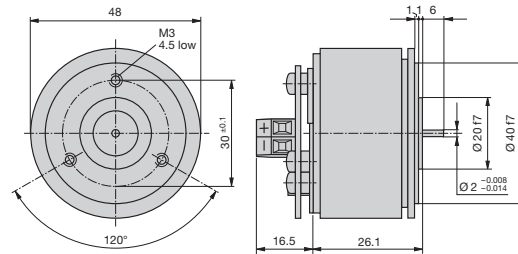

Fig. 1. KINAX 2W2 with standard drive shaft at front only, Ø 2 mm, length 6 mm [0.078", 0.236"], screw terminal version.

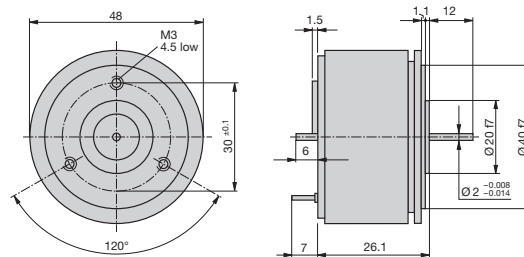

Fig. 2. KINAX 2W2 with special drive shaft at front and at rear. front: Ø 2 mm, length 12 mm [0.078", 0.472"]. Rear: Ø 2 mm, length 6 mm [0.078", 0.236"]

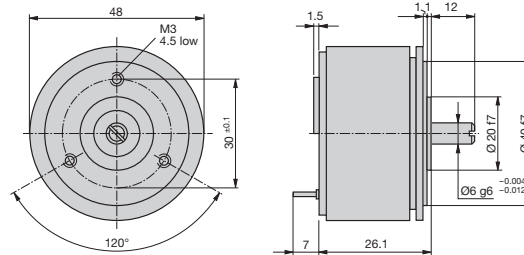

Fig. 3. KINAX 2W2 with special drive shaft at front only, Ø 6 mm, length 12 mm [0.236", 0.472"].

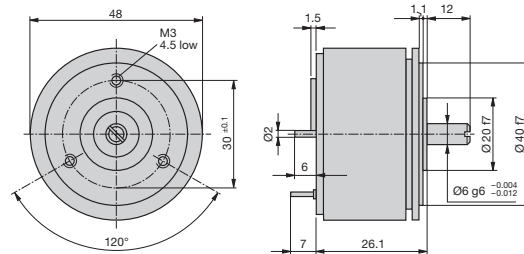

Fig. 4. KINAX 2W2 with special drive shaft at front and at rear. front: Ø 6 mm, length 12 mm [0.236", 0.472"]. Rear: Ø 2 mm, length 6 mm [0.078", 0.236"]

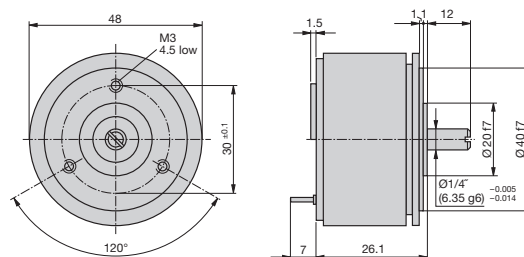

Fig. 5. KINAX 2W2 with special drive shaft at front only, Ø 1/4", length 12 mm [0.472"].

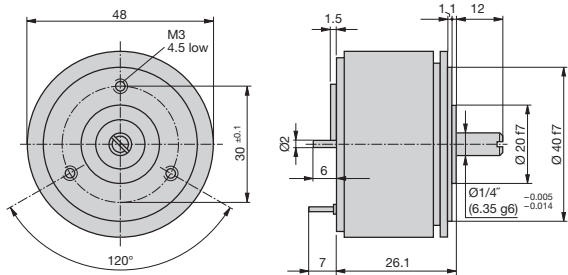

Fig. 6. KINAX 2W2 with special drive shaft at front and at rear. Front: dia. 1/4", length 12 mm [0.472"]. Rear: dia. 2 mm, length 6 mm [0.236"].

## 6. Mounting

### Mechanical mounting

All versions of the transmitter can be mounted either directly or by means of 3 mounting clips to the item being measured. Both methods of mounting and the relevant drilling and cut-out plans can be seen from Table:

Mounting versions <sup>2</sup>		Drilling and cut-out diagrams for mounting transmitters
directly		<p>Load max. [Ω] with output 20 mA</p> <p>Power supply [V]</p>
with 3 clamps		

### Mounting/positioning

Three **M3** screws are needed for the "directly" mounted versions and three **M4** screws for those "with clamps". The screws are not supplied, because the required length varies according to the thickness of the mounting surface.



When deciding where to install the transmitter (measuring location), take care that the "Ambient conditions" given in Section "5. Technical data" are **not exceeded**.

Angular position transmitters of the KINAX 2W2 range do not require a mechanical zero position mark (however, this is made if required by the customer). After mounting, the transmitter can be moved to any position and configured using the 2W2 software. A power supply connection to the KINAX 2W2 is not required in order to use the 2W2 configuration software (Fig. 7; AUX switch on the PK 610 in the ON position).



**The angular position transmitter must only be programmed outside of the Ex area!**

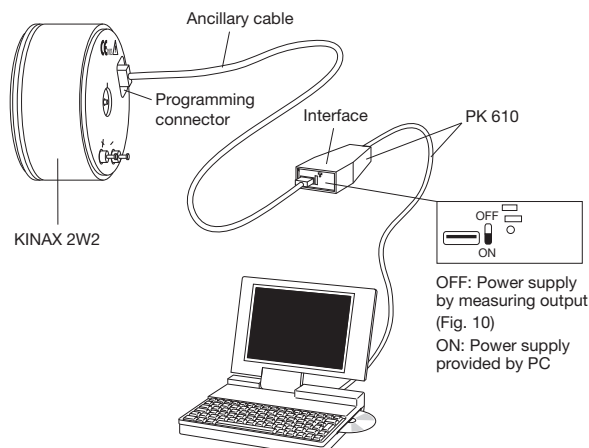

Fig. 7. Connection diagram programming



If you program the KINAX 2W2 with a connected power supply, then the switch on the interface PK610 must be imperative switched to OFF. If this is ignored, this can lead to the destruction of the device.

### Positioning procedure for the KINAX 2W2

1. Mount the angular position transmitter and mechanically connect it to the object to be measured. Connect the KINAX 2W2 to the programming device according to Fig. 7. Start the 2W2 configuration software. If necessary, configure the device with the required measuring range data.
2. Place the measuring device in a defined position (preferably the zero position).
3. Select the "Adjustment" menu item under "SERVICE" in the configuration software. In the "Mechanical position" window enter the current angle of the measuring device and then select "Adjust". The measuring device is now configured for the defined angle.

## 7. Electrical connections

For connecting the external wires, the transmitter has 2 soldering pins at the back (Fig. 8) or a connecting print with screw terminals (Fig. 9). The soldering posts suffice Protection Class IP 00 acc. to IEC 60 529.

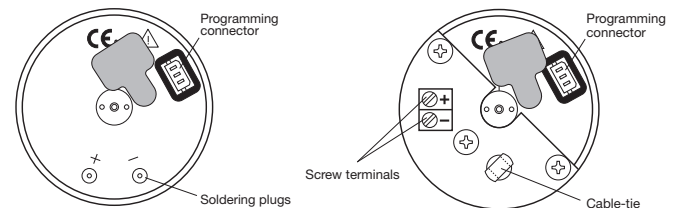

Fig. 8. Connection with soldering plugs Fig. 9. Connection with screw terminals



Note that, ...

... the data required to carry out the prescribed measurement must correspond to those marked on the nameplate of the KINAX 2W2 (Range, Output, Supply Voltage)!

... the total loop resistance connected to the output (receiver plus leads) **does not** exceed the maximum permissible value  $R_{ext.}$ ! See "Measuring output" in Section "5. Technical data" for the maximum values of  $R_{ext.}$ !

... twisted cores must be used for the measured variable input and output leads and routed as far away as possible from power cables!

In all other respects, observe all local regulations when selecting the type of electrical cable and installing them!



In the case of "Intrinsically safe" explosion-proof versions [Ex ia] IIC, the supplementary information given on the EC-Type-Examination Certificate, the EN 60 079-14 and also local regulations applicable to electrical installations in explosion hazard areas must be taken into account!



Do not **excessively heat** the soldering posts! Solder using a **small pencil bit soldering iron!**

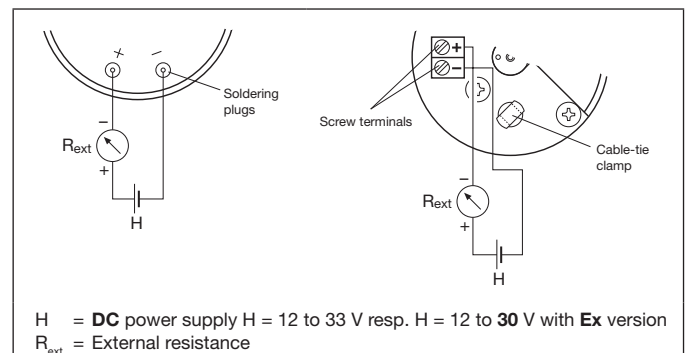

Fig. 10. Connection diagrams for 2-wire connection.

## 8. Setting the beginning and end

### Fine adjustment

The analog output can be finely adjusted using the 2W2 configuration software. Select the menu item "Adjustment" under "SERVICE". In the "Analog output" window, the zero position and the end value can now be adjusted.

### Procedure:

1. Put the transmitter into operation and connect the programming device according to Fig. 7 (AUX switch on the PK 610 in the OFF position).
2. Place the measuring device in the zero position, i.e. in the position in which the KINAX 2W2 should output 4 mA. Adjust with the "ZERO" virtual knob until the output is correct.

3. Place the measuring object in the end position, i.e. in the position, in which the KINAX 2W2 should output 20 mA. Adjust with the virtual knob "Span" until the output signal is correct.

4. Close the adjustment with the "Done" button.

The adjusting range of the zero position and span is 5%. If this range is not sufficient, the span can be adapted by changing the mechanical characteristics (increase/decrease the measuring span).

### Simulation mode

The 2W2 configuration software supports the operation of the KINAX 2W2 in simulation mode. The simulation of the measured value allows the subsequent chain of devices to be tested during the installation phase.

#### Procedure:

1. Select the "Simulation" menu item under "Service" in the configuration software.
2. The window displays the device configuration. After the entry of the required angle, the analog output is set in accordance with the device configuration.

## 9. Electric commissioning

- Provide a separate power supply for the device in case of consumer loads with high interference levels.
- Install the entire plant in an EMC-compatible manner. Installation environment and wiring can affect the EMC of the device.
- For Versions with explosion protection:



The regulations according to EN 60079-14, the equipment safety law, the generally acknowledged rules of the industry and these operating instructions are applicable for installation and operation.

## 10. Maintenance

The device is free of maintenance. Repairs may only be carried out by authorized authorities.

## 11. Specification and ordering information

Significance of the digits 1. to 12.

Description	Order code
<b>1. Version of the transmitter</b>	<b>760-</b>
Standard, measuring output non intrinsically safe	1
Ex ia IIC T6, ATEX Measuring output intrinsically safe	2
<b>2. Mechanical angle range</b>	
Angle range up to 50 °	1
Angle range > 50 to 350 °	2
<b>3. Drive shaft</b>	
Standard, dia. 2 mm [0.078"] at front, length 6 mm [0.236"]	1
Special, dia. 2 mm [0.078"] at front, length 12 mm [0.472"], dia. 2 mm [0.078"] at rear, length 6 mm [0.236"]	2
Special, dia. 6 mm [0.236"] at front, length 12 mm [0.472"]	3
Special, dia. 6 mm [0.236"] at front, length 12 mm [0.472"], dia. 2 mm [0.078"] at rear, length 6 mm [0.236"]	4
Special, dia. 1/4" at front, length 12 mm [0.472"]	5
Special, dia. 1/4" at front, length 12 mm [0.472"], dia. 2 mm [0.078"] at rear, length 6 mm [0.236"]	6
<b>4. Output variable</b>	
Current, 4 to 20 mA, 2-wire connection	1
<b>5. Electrical connection</b>	
Connection to soldering terminals	1
Connection to screw terminals	2
<b>6. Test certificate</b>	
Without test certificate	0
Test certificate in German	D
Test certificate in English	E
<b>7. Configuration</b>	
Basic configuration, programmed	0
Programmed to order	1
Programmed to order, with zero position mark on the drive shaft disk	2
<b>8. Sense of rotation</b>	
Programmed for sense of rotation clockwise	0
Programmed for sense of rotation counter-clockwise	1
Programmed for V-characteristic	2

Description	Order code
<b>9. Measuring range</b>	
[°angle], 0 to final value	9
V characteristic [±°angle], Min.:	z
Line 9: Admissible values Final value ≥ 10 to 50° with selected angle range 50° > 50 to 350° with selected angle range 350° Switching point > final value, max. 60° with angle range 50° > final value, max. 360° with angle range 350°	
Line Z: Admissible values Minimum value [±°angle] ≥ 0 Maximum value [±°angle] ≤ 25° with angle range 50°, span (max.-min.) ≥ 5° > 25° to 175° with angle range 350°, span ≥ 25° symmetrical about the center line, e.g. [±°angle], min. value = 15, max. value = 120, correspond -120 to -15 to 0 to 15 to 120° (input) and +20 to 4 to < 4 to 4 to +20 mA (output)	
<b>10. Characteristic of output variable</b>	
Linear	0
Function X to the power 1/2	1
Function X to the power 3/2	2
Function X to the power 5/2	3
Customized (give an algorithm or fixed points (23 for the complete output range))	4
Lines 1 to 4: Not possible with V-characteristic (line 2 in feature 8, sense of rotation)	
<b>11. Climatic rating</b>	
Standard climatic rating (annual mean relative humidity ≤ 90 %)	0
Improved climatic rating (annual mean relative humidity ≤ 95 %)	1
<b>12. Marine Version</b>	
Without	0

## 12. Declaration of conformity

	<b>EG - KONFORMITÄTSERKLÄRUNG EC DECLARATION OF CONFORMITY</b>	
Dokument-Nr. / Document No.: WT2W2_CE-konf.docx		
Hersteller/ Manufacturer: <b>Camille Bauer Metrawatt AG</b> Switzerland		
Anschrift / Address: <b>Aargauerstrasse 7</b> CH-5610 Wohlen		
Produktbezeichnung/ Product name: <b>Messumformer für Drehwinkel</b> Transmitter for angular position		
Typ / Type: <b>KINAX 2W2</b>		
Das bezeichnete Produkt stimmt mit den Vorschriften folgender Europäischer Richtlinien überein, nachgewiesen durch die Einhaltung folgender Normen: The above mentioned product has been manufactured according to the regulations of the following European directives proven through compliance with the following standards:		
<b>Richtlinie / Directive</b>	<b>2004/108/EG(EMC)</b> Elektromagnetische Verträglichkeit - EMV-Richtlinie Electromagnetic compatibility - EMC directive	
<b>Norm / Standard</b>	<b>EN 61000-6-2: 2005</b> Fachgrundnormen - Störfestigkeit für Industriebereiche Generic standards - Immunity for industrial environments <b>EN 61000-6-3: 2007</b> Fachgrundnormen - Störaussendung für Wohnbereich, Geschäfts- und Gewerbebereiche sowie Kleinbetriebe Generic standards - Emission standard for residential, commercial and light-industrial environments	
<b>Prüfungen / Tests</b>	IEC 61000-4-2 IEC 61000-4-3 IEC 61000-4-4 IEC 61000-4-5 IEC 61000-4-6	EN 55011
<b>Richtlinie / Directive</b>	<b>2006/95/EG(CEC)</b> Elektrische Betriebsmittel zur Verwendung innerhalb bestimmter Spannungsgrenzen - Niederspannungsrichtlinie - CE-Kennzeichnung : 95 Electrical equipment for use within certain voltage limits - Low Voltage Directive - Attachment of CE marking : 95	
<b>Norm / Standard</b>	<b>EN 61010-1: 2010</b> Sicherheitsbestimmungen für elektrische Mess-, Steuer-, Regel- und Laborgeräte - Teil 1: Allgemeine Anforderungen Safety requirements for electrical equipment for measurement, control and laboratory use - Part 1: General requirements	
Die explosionsgeschützte Ausführung stimmt mit folgender Richtlinie überein: The explosion protected variant accords to the following directive:		
<b>Richtlinie / Directive</b>	<b>94/9/EG(EG)</b> Geräte und Schutzsysteme zur bestimmungsgemäßen Verwendung in explosionsgefährdeten Bereichen Equipment and protective systems intended for use in potentially explosive atmospheres	
<b>Norm / Standard</b>	<b>EN 60079-0: 2012 / -11: 2012</b> Explosionsfähige Atmosphäre / Explosive atmospheres - 0: Geräte - Allgemeine Anforderungen / General requirements - 11: Geräteschutz durch Eigensicherheit "i" / Equipment protection by intrinsic safety "i"	
<b>Nachweis / Proof</b>	<b>ZELM 03 ATEX 0123</b> Notified Body No. 0102: PTB D-38115 Braunschweig	
Ort, Datum / Place, date: Wohlen, 22. August 2014		
Unterschrift / signature:		
M. Ulrich Leiter Technik / Head of engineering		 Qualitätsmanager / Quality manager
0_FO_13; Aktualisiert: 17.07.14		