



# VMD420

## Voltage and frequency monitor

### for monitoring of 3(N)AC systems up to 0...500 V

for undervoltage, overvoltage, underfrequency, overfrequency

Software version: D238 V2.2x



**Bender GmbH & Co. KG**

P.O. Box 1161 • 35301 Gruenberg • Germany

Londorfer Strasse 65 • 35305 Gruenberg • Germany

Tel.: +49 6401 807-0 • Fax: +49 6401 807-259

E-Mail: [info@bender.de](mailto:info@bender.de) • [www.bender.de](http://www.bender.de)

© Bender GmbH & Co. KG

All rights reserved.

Reprinting only with permission of the publisher.

Subject to change!

Photos: Bender archives

## Table of Contents

<b>1. Important information</b>	<b>7</b>
1.1 How to use this manual	7
1.2 Technical support: service and support	8
1.2.1 First level support	8
1.2.2 Repair service	8
1.2.3 Field service	9
1.3 Training courses	10
1.4 Delivery conditions	10
1.5 Inspection, transport and storage	10
1.6 Warranty and liability	11
1.7 Disposal	12
<b>2. Safety instructions</b>	<b>13</b>
2.1 General safety instructions	13
2.2 Work activities on electrical installations	13
2.3 Intended use	14
<b>3. Function</b>	<b>15</b>
3.1 Device features	15
3.2 Function	15
3.2.1 Preset function	16
3.2.2 Automatic self test	17
3.2.3 Manual self test	17
3.2.4 Functional faults	17
3.2.5 Fault memory	17
3.2.6 Assigning alarm categories to alarm relays K1/K2	18
3.2.7 Time delays t, ton and toff	18
3.2.8 Password protection (on, OFF)	18
3.2.9 Factory setting FAC	19

3.2.10 Erasable history memory .....	19
3.2.11 Alarm LEDs show which relay is in the alarm state .....	19
3.2.12 Starting a device using a simulated alarm S.AL .....	19
<b>4. Installation, connection and commissioning .....</b>	<b>21</b>
4.1 Fast commissioning for $U_n = 400\text{ V}$ , 50 Hz .....	21
4.2 Installing the device .....	23
4.2.1 DIN rail mounting: .....	23
4.2.2 Screw mounting .....	23
4.3 Wiring of the device .....	24
4.4 Commissioning preset function/factory setting .....	25
<b>5. Operation and setting .....</b>	<b>27</b>
5.1 Getting to know the user interface .....	27
5.2 Understanding of standard display indications .....	29
5.3 Getting to know keys and key functions .....	30
5.4 Query values .....	31
5.5 Starting the manual self test .....	32
5.6 Deactivating fault memory .....	33
5.7 Calling up or leaving the menu .....	33
5.8 Carrying out settings in the menu .....	33
5.8.1 Selecting menu items .....	33
5.8.2 Carrying out settings in the menu item AL .....	36
5.8.3 Carrying out settings in the menu item out .....	39
5.8.4 Carrying out settings in the menu item t .....	44
5.8.5 Carrying out settings in the menu item SEt .....	45
5.8.6 Querying information in menu item INF .....	48
5.8.7 Querying and clearing fault memory in the menu item HIS .....	49

<b>6. Technical data</b> .....	<b>51</b>
6.1 Data in tabular form .....	51
6.2 Standards, approvals and certifications .....	55
6.3 Ordering information .....	55
<b>INDEX</b> .....	<b>57</b>



# 1. Important information

## 1.1 How to use this manual



This manual is intended for **qualified personnel** working in electrical engineering and electronics!

### Always keep this manual within easy reach for future reference.

To make it easier for you to understand and revisit certain sections in this manual, we have used symbols to identify important instructions and information. The meaning of these symbols is explained below:



This signal word indicates that there is a **high risk of danger** that will result in **electrocution** or **serious injury** if not avoided.



This signal word indicates a **medium risk of danger** that can lead to **death** or **serious injury** if not avoided.



This signal word indicates a **low level risk** that can result in **minor** or **moderate injury or damage to property** if not avoided.



This symbol denotes information intended to assist the user in making **optimum use** of the product.

This manual has been compiled with great care. It might nevertheless contain errors and mistakes. Bender cannot accept any liability for injury to persons or damage to property resulting from errors or mistakes in this manual.

## 1.2 Technical support: service and support

For commissioning and troubleshooting Bender offers you:

### 1.2.1 First level support

Technical support by phone or e-mail for all Bender products

- Questions concerning specific customer applications
- Commissioning
- Troubleshooting

**Telephone:** +49 6401 807-760\*  
**Fax:** +49 6401 807-259  
In Germany only: 0700BenderHelp (Tel. and Fax)  
**E-mail:** support@bender-service.de

### 1.2.2 Repair service

Repair, calibration, update and replacement service for Bender products

- Repairing, calibrating, testing and analysing Bender products
- Hardware and software update for Bender devices
- Delivery of replacement devices in the event of faulty or incorrectly delivered Bender devices
- Extended guarantee for Bender devices, which includes an in-house repair service or replacement devices at no extra cost

**Telephone:** +49 6401 807-780\*\* (technical issues)  
+49 6401 807-784\*\*, -785\*\* (sales)  
**Fax:** +49 6401 807-789  
**E-mail:** repair@bender-service.de

Please send the devices for **repair** to the following address:

Bender GmbH, Repair-Service,  
Londorfer Str. 65,  
35305 Grünberg

### 1.2.3 Field service

On-site service for all Bender products

- Commissioning, configuring, maintenance, troubleshooting of Bender products
- Analysis of the electrical installation in the building (power quality test, EMC test, thermography)
- Training courses for customers

**Telephone:** +49 6401 807-752\*\*, -762 \*\*(technical issues)  
+49 6401 807-753\*\* (sales)  
**Fax:** +49 6401 807-759  
**E-mail:** [fieldservice@bender-service.de](mailto:fieldservice@bender-service.de)  
**Internet:** [www.bender-de.com](http://www.bender-de.com)

\*Available from 7.00 a.m. to 8.00 p.m. 365 days a year (CET/UTC+1)

\*\*Mo-Thu 7.00 a.m. - 8.00 p.m., Fr 7.00 a.m. - 13.00 p.m

### **1.3 Training courses**

Bender is happy to provide training regarding the use of test equipment. The dates of training courses and workshops can be found on the Internet at [www.bender-de.com](http://www.bender-de.com) -> Know-how -> Seminars.

### **1.4 Delivery conditions**

Bender sale and delivery conditions apply.

For software products the "Softwareklausel zur Überlassung von Standard-Software als Teil von Lieferungen, Ergänzung und Änderung der Allgemeinen Lieferbedingungen für Erzeugnisse und Leistungen der Elektroindustrie" (software clause in respect of the licensing of standard software as part of deliveries, modifications and changes to general delivery conditions for products and services in the electrical industry) set out by the ZVEI (Zentralverband Elektrotechnik- und Elektronikindustrie e. V.) (German Electrical and Electronic Manufacturer's Association) also applies.

Sale and delivery conditions can be obtained from Bender in printed or electronic format.

### **1.5 Inspection, transport and storage**

Inspect the dispatch and equipment packaging for damage, and compare the contents of the package with the delivery documents. In the event of damage in transit, please contact Bender immediately.

The devices must only be stored in areas where they are protected from dust, damp, and spray and dripping water, and in which the specified storage temperatures can be ensured.

## 1.6 Warranty and liability

Warranty and liability claims in the event of injury to persons or damage to property are excluded if they can be attributed to one or more of the following causes:

- Improper use of the device.
- Incorrect mounting, commissioning, operation and maintenance of the device.
- Failure to observe the instructions in this operating manual regarding transport, commissioning, operation and maintenance of the device.
- Unauthorised changes to the device made by parties other than the manufacturer.
- Non-observance of technical data.
- Repairs carried out incorrectly and the use of replacement parts or accessories not approved by the manufacturer.
- Catastrophes caused by external influences and force majeure.
- Mounting and installation with device combinations not recommended by the manufacturer.

This operating manual, especially the safety instructions, must be observed by all personnel working on the device. Furthermore, the rules and regulations that apply for accident prevention at the place of use must be observed.

## 1.7 Disposal

Abide by the national regulations and laws governing the disposal of this device. Ask your supplier if you are not sure how to dispose of the old equipment.

The directive on waste electrical and electronic equipment (WEEE directive) and the directive on the restriction of certain hazardous substances in electrical and electronic equipment (RoHS directive) apply in the European Community. In Germany, these policies are implemented through the "Electrical and Electronic Equipment Act" (ElektroG). According to this, the following applies:

- Electrical and electronic equipment are not part of household waste.
- Batteries and accumulators are not part of household waste and must be disposed of in accordance with the regulations.
- Old electrical and electronic equipment from users other than private households which was introduced to the market after 13 August 2005 must be taken back by the manufacturer and disposed of properly.

For more information on the disposal of Bender devices, refer to our homepage at [www.bender-de.com](http://www.bender-de.com) -> Service & support.

## 2. Safety instructions

### 2.1 General safety instructions

Part of the device documentation in addition to this manual is the enclosed "Safety instructions for Bender products".

### 2.2 Work activities on electrical installations



Only **qualified personnel** are permitted to carry out the work necessary to install, commission and run a device or system.



**DANGER**

#### **Risk of electrocution due to electric shock!**

Touching live parts of the system carries the risk of:

- An electric shock
- Damage to the electrical installation
- Destruction of the device

**Before installing and connecting the device, make sure that the installation has been *de-energised*.** Observe the rules for working on electrical installations.

If the device is used outside the Federal Republic of Germany, the applicable local standards and regulations must be complied with. The European standard EN 50110 can be used as a guide.

## 2.3 Intended use

The voltage monitor VMD420 monitors 3(N)AC systems in the frequency range 15...460 Hz for undervoltage, overvoltage, underfrequency and overfrequency. The devices are designed for the nominal voltage range  $U_n = 0...500$  V. Separate supply voltage  $U_s$  is required.

In order to meet the requirements of the applicable standards, customised parameter settings must be made on the equipment in order to adapt it to local equipment and operating conditions. Please heed the limits of the range of application indicated in the technical data.

Any use other than that described in this manual is regarded as improper.

## 3. Function

### 3.1 Device features

- VMD420 requires separate supply voltage  $U_s$
- Undervoltage, overvoltage, underfrequency and overfrequency monitoring of 3(N)AC systems up to AC 0...500 V / 0...288 V
- Asymmetry, phase failure and phase sequence monitoring
- Start-up delay, response delay and delay on release adjustable
- Adjustable switching hysteresis for U and f
- r.m.s. value measurement AC +DC
- Measured value display via multi-functional LC display
- LEDs for Power on, Alarm 1 and Alarm 2
- Fault memory for operating value
- Cyclical self test
- Test / reset button, internal
- Two separate alarm relays with one changeover contact each (K1/K2)
- N/C or N/O operation and fault memory behaviour selectable
- Password protection for device setting
- Sealable transparent cover
- Screw-type or push-wire terminals alternatively

### 3.2 Function

Once the supply voltage is applied, the start-up delay  $t$  is activated. Measured values changing during this time do not influence the switching state of the alarm relays.

The devices provide two separately adjustable response values (overvoltage/undervoltage). When the measuring quantity exceeds the response value (Alarm 1) or falls below the response value (Alarm 2), the time of the response delays  $t_{on} 1/2$  begins. When the response delay has elapsed, the alarm relays switch and the alarm LEDs light. If the measured value falls below

or exceeds the adjusted delay on release (response value plus hysteresis) after the alarm relays have switched, the delay on release  $t_{\text{off}}$  starts. When the delay time  $t_{\text{off}}$  has elapsed, the alarm relays switch back to their initial position. With the fault memory activated, the alarm relays do not change their actual state until the reset button R is pressed.

### 3.2.1 Preset function

After connecting the system to be monitored for the first time, the response values for overvoltage and undervoltage (Alarm 1/2) are automatically set once to:

Response value overvoltage ( $> U$ ):  $1.1 U_n$

Response value undervoltage ( $< U$ ):  $0.85 U_n$

Response value overfrequency ( $> f$ ) at 16.7 Hz, 50 Hz, 60 Hz:  $f_n + 1 \text{ Hz}$

Response value overfrequency ( $> f$ ) at 400 Hz:  $f_n + 1 \text{ Hz}$

Response value underfrequency ( $< f$ ) at 16.7 Hz, 50 Hz, 60 Hz:  $f_n - 1 \text{ Hz}$

Response value underfrequency ( $< f$ ) at 400 Hz:  $f_n - 1 \text{ Hz}$

Preset VMD420				
Measuring principle	$U_n$	Preset operating range	Response value $< U$	Response value $> U$
Three-phase measurement: 3Ph	400 V (L1, L2, L3)	340...440 V	340 V	440 V
	208 V (L1, L2, L3)	177...229 V	177 V	229 V
Only when the preset function (Menu/SEt/PrE) has been started manually, the following response values can be set:				
Phase-to-neutral voltage measurement: 3n	230 V (L1, L2, L3, N)	196...253 V	196 V	253 V
	120 V (L1, L2, L3, N)	102...132 V	102 V	132 V

If the measured voltage is not within the preset operating range listed in the table, the message "AL not Set" appears on the display. Therefore it is necessary to set the response values for Alarm 1 (AL1) and Alarm 2 (AL2) manually. A detailed description of the process is given in the chapter "parameter setting".

After restoring the factory settings, the preset function is automatically active again. During operation, the preset function can be started manually via the menu SEt.

### 3.2.2 Automatic self test

The device automatically carries out a self test after connection to the system to be monitored and later every hour. During the self test internal functional faults are detected and will appear in form of an error code on the display. The alarm relays are not checked during this test.

### 3.2.3 Manual self test

After pressing the test button for  $> 1.5$  s, the device carries out a self test. During this test, internal functional faults are detected and will be displayed in form of an error code. The alarm relays are not checked during this test. While the test button T is pressed and held down, all device-related display elements appear on the display.

### 3.2.4 Functional faults

If an internal malfunction occurs, all three LEDs flash. An error code will appear on the display (E01...E32). In such a case please contact the Bender Service.

### 3.2.5 Fault memory

The fault memory can be activated, deactivated or can be set to continuous mode (con). If the fault memory is set to "con" mode, the alarm parameters remain stored even on failure of the supply voltage.

### 3.2.6 Assigning alarm categories to alarm relays K1/K2

Different alarm categories can be assigned to the alarm relays K1/K2 via the menu "out".

### 3.2.7 Time delays $t$ , $t_{\text{on}}$ and $t_{\text{off}}$

The times  $t$ ,  $t_{\text{on}}$  and  $t_{\text{off}}$ , described below, delay the output of alarms via LEDs and relays.

#### Start-up delay $t$

After connection to the supply voltage  $U_S$ , the alarm indication is delayed by the preset time  $t$  (0...300 s).

#### Response delay $t_{\text{on}}$

When the response value is reached, the voltage monitor requires the response time  $t_{\text{an}}$  until the alarm is activated.

A preset response delay  $t_{\text{on}}$  (0...300 s) adds up to the device-related operating time  $t_{\text{ae}}$  and delays alarm signalling

(total delay time  $t_{\text{an}} = t_{\text{ae}} + t_{\text{on}}$ ).

If the fault does not continue to exist before the time of the response delay has elapsed, an alarm will not be signalled.

#### Delay on release $t_{\text{off}}$

When the alarm no longer exists and the fault memory is deactivated, the alarm LEDs go out and the alarm relays switch back to their initial position.

When the delay on release (0...300 s) has been preset, the alarm state is continuously maintained for the selected period.

### 3.2.8 Password protection (on, OFF)

When password protection is enabled (on), settings can only be carried out after entering the password (0...999). If you cannot operate your device because you cannot remember your password, please contact [info@bender-service.com](mailto:info@bender-service.com).

### 3.2.9 Factory setting FAC

After activating the factory setting, all settings previously changed are reset to delivery status. In addition, the preset function allows automatic adaptation of the response values in relation to the nominal voltage  $U_n$ .

### 3.2.10 Erasable history memory

The first alarm value that occurs will be saved in this memory. Subsequent alarms do not overwrite this "old" value. The memory can be cleared using the Clr key in the menu HiS. This function is not password protected.

### 3.2.11 Alarm LEDs show which relay is in the alarm state

When the menu item **LEd**  is activated, the alarm LED AL1 indicates that K1 is in the alarm state. When AL2 lights up, K2 is in the alarm state. An alarm relay cannot switch to the alarm state unless an alarm category has been assigned to it.

When the menu item **LEd**  is deactivated, AL1 signals overvoltage, AL2 signals undervoltage, both LEDs AL1 and AL2 light up in case of frequency alarm.

### 3.2.12 Starting a device using a simulated alarm S.AL

If the menu item S.AL has been activated in the out menu, K1 resp. K2 switches back to the alarm state once the supply voltage is applied. This alarm state is maintained for the set duration  $t + t_{on1}$ . Once this time has elapsed, K1 resp. K2 switches back to the initial position provided that no fault is detected at the measuring input.

The following diagrams show the effect of a fault during a simulated alarm.

Faults at the measuring input and the resulting condition of the alarm relay K1 (K2) are shown as a hatched area.

The fault for K1 shown in the time diagram below, by way of example, has started during the S.AL phase:

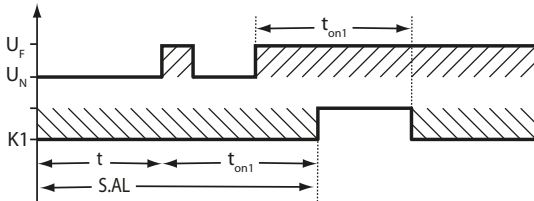

The fault for K1 shown in the time diagram below, by way of example, started when the S.AL phase has elapsed:

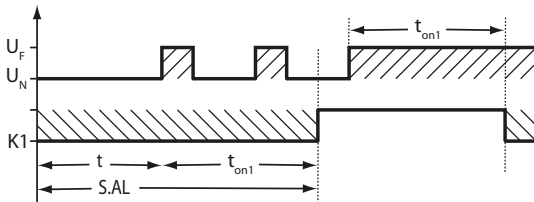

## 4. Installation, connection and commissioning



Only **qualified personnel** are permitted to carry out the work necessary to install, commission and run a device or system.



**DANGER**

### **Risk of electrocution due to electric shock!**

Touching live parts of the system carries the risk of:

- An electric shock
- Damage to the electrical installation
- Destruction of the device

**Before installing and connecting the device, make sure that the *installation* has been *de-energised*. Observe the rules for working on electrical installations.**

### 4.1 Fast commissioning for $U_n = 400 \text{ V}$ , 50 Hz

If you are already familiar with voltage monitors, you can reduce the time for commissioning and connection using this brief description.

1. Check that the three-phase system being monitored is operated with a nominal voltage of  $U_n = 400 \text{ V}$  and 50 Hz. This is the precondition for an automatic setting of the response values (Preset) after the first connection to the nominal voltage.
2. Make sure that the voltage monitor is in the delivery status (factory setting has not been changed).

3. When the conditions 1 and 2 are satisfied, you can connect the voltage monitor to the three-phase system to be monitored according to the wiring diagram (Seite 24). The following predefined response values will be set automatically:

VMD420			
$U_n, f_n$	Preset operating range	Response value < U, < f	Response value > U, > f
400 V (L1, L2, L3)	340 V...440 V	340 V	440 V
50 Hz	47...53 Hz	49 Hz	51 Hz

4. The currently measured phase-to-phase voltage between L1 and L2 appears on the display. Use the UP and DOWN keys to query other parameters:
- phase-to-phase voltage L2, L3
  - phase-to-phase voltage L1, L3
  - asymmetry
  - system frequency
  - phase sequence

For detailed information about the preset function and other voltage ranges refer to Seite 16.

If you want to reset the voltage monitors to factory settings, refer to Seite 19.

## 4.2 Installing the device



Abb. 4.1: Dimension diagram and drawing for screw fixing

### 4.2.1 DIN rail mounting:

1. Open the front plate cover at the lower part marked by an arrow.
2. Snap the rear mounting clip of the device into place in such a way that a safe and tight fit is ensured.

### 4.2.2 Screw mounting

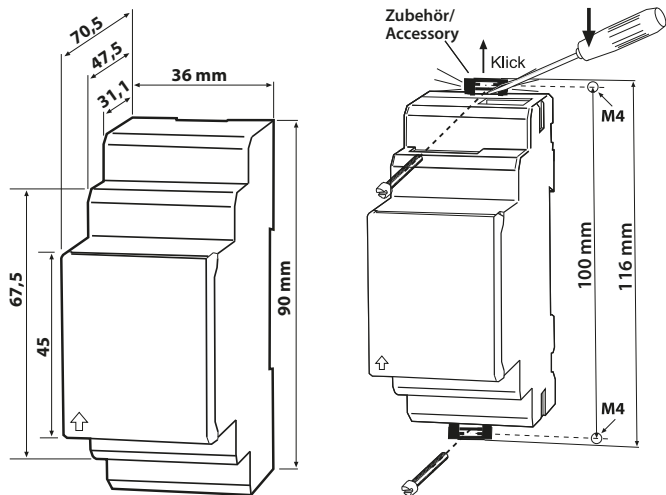
1. Use a tool to move the rear mounting clips (a second mounting clip required, see ordering information) to a position that it projects beyond the enclosure.
2. Fix the device using two M4 screws.

### 4.3 Wiring of the device

Connect the device according the wiring diagram.



Abb. 4.2: Wiring diagram

## 4.4 Commissioning preset function/factory setting

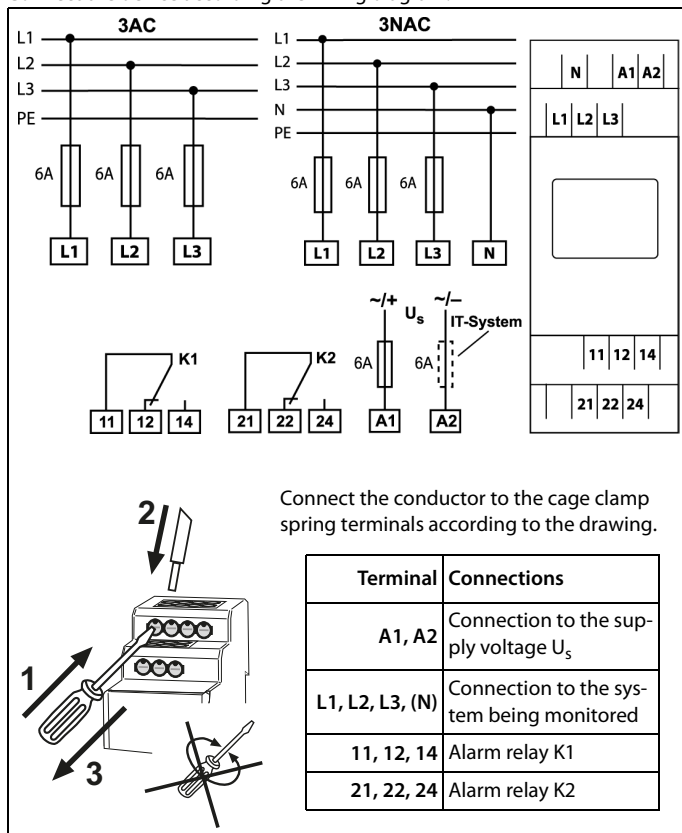

**CAUTION**

### **Material damage by improper connection of the device!**

*Prior to commissioning make sure that the device is properly connected!*



*After connecting a brand-new VMD420... to a standard system of  $U_n = 400\text{ V } 50\text{ Hz}$ , the response values are automatically set by the internal preset function:*

*Overvoltage = 440 V (400 V + 10 %) (50 Hz + 1 Hz)*

*Undervoltage = 340 V (400 V - 15 %) (50 Hz - 1 Hz)*

*Other operating ranges of the preset function are given in the technical data "response values" and in the description of the function.*



*During the first start-up process the following response values are automatically set related to  $U_n$ :*

*Response value: overvoltage ( $> U$ ): 1.1  $U_n$*





*Response value: undervoltage ( $< U$ ): 0.85  $U_n$*

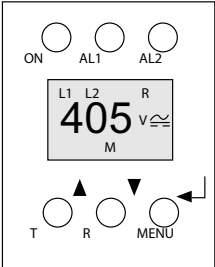

**Factory settings**

Hysteresis U:	5 %
Underfrequency < Hz	OFF
Overfrequency > Hz	OFF
Hysteresis frequency (Hys Hz):	0.2 Hz
Fault memory M:	on
Operating principle K1 (> U, Asy):	N/O operation (n.o.)
Operating principle K2 (< U, Asy):	N/C operation (n.c.)
AL1/AL2 indicate the alarm state of K1/K2 (LEd):	OFF
Alarm to K1/K2 (S.AL) when the device is started:	OFF
Asymmetry:	30 %
Phase sequence monitoring:	OFF
Start-up delay:	$t = 0 \text{ s}$
Response delay:	$t_{on1} = 0 \text{ s}$ $t_{on2} = 0 \text{ s}$
Delay on release:	$t_{off} = 0.5 \text{ s}$
Method of measurement:	3Ph (phase-to-phase voltage measurement)
Password:	0, Off

## 5. Operation and setting

### 5.1 Getting to know the user interface

Device front	Element	Function
	ON	Power On LED, green
	AL1, AL2	<b>Menu item LED  deactivated:</b> LED Alarm 1 lights (yellow): Response value > U exceeded, LED Alarm 2 lights (yellow): Response value < U reached
	AL1 und AL2	<b>Menu item LED  deactivated:</b> Both LEDs light when the frequency response values > Hz or < Hz are reached
	AL1, AL2	<b>Menu item LED  activated:</b> LED Alarm 1 lights (yellow): K1 signals an arbitrary alarm, LED Alarm 2 lights (yellow): K2 signals an arbitrary alarm
	405 V, M	Display in standard mode: $U_n = 405 \text{ V}$ ; Fault memory active
	T,  ▲	Test button (> 1.5 s): Indication of usable display ele- ments, starting a self test; Up key (< 1.5 s): Menu items/values

Device front	Element	Function
	R, 	Reset button (> 1.5 s): Deleting the fault memory; Down key (< 1.5 s): Menu items/values
	MENU, 	MENU key (> 1.5 s): Starting the menu mode; Enter key (< 1.5 s): Confirm menu item, submenu item and value. Enter key (> 1.5 s): Back to the next higher menu level

For further information about the menu item **LEd**  refer to page 19.

## 5.2 Understanding of standard display indications







Abb. 5.1: Standard displays

- |   |   |
|---|---|
| <p>1 DISPLAY PHASE-TO-PHASE CONDUCTORS L1-L3:<br/>Displays active phase-to-phase conductors.</p> <p>2 DISPLAY ASYMMETRY:<br/>Displays the asymmetry value in %.</p> <p>3 DISPLAY NEUTRAL CONDUCTOR:<br/>Neutral conductor is active.</p> <p>4 DISPLAY PHASE SEQUENCE:<br/>R = clockwise<br/>L = anticlockwise</p> <p>5 DISPLAY AREA for UNITS:<br/>Displays the value of a unit.<br/>% = per cent (asymmetry and hysteresis)<br/>Hz = frequency in hertz<br/>s = second<br/>k = kilo<br/>V = volt</p> | <p>6 DISPLAY TYPE OF VOLTAGE:<br/>Displays the type of voltage.</p> <p>7 PASSWORD PROTECTION ENABLED:<br/>Indicates that password protection is activated.</p> <p>8 DISPLAY OPERATING MODE:<br/>Displays the operating mode of K1/K2;<br/>respectively LEDs AL1/AL2 indicate the alarm state of K1/K2</p> <p>9 FAULT MEMORY ACTIVATED:<br/>Displays activated fault memory.</p> <p>10 DISPLAY HYSTERESIS:<br/>Displays hysteresis in %.</p> <p>11 DISPLAY VALUE:<br/>Displays values.</p> |
|---|---|

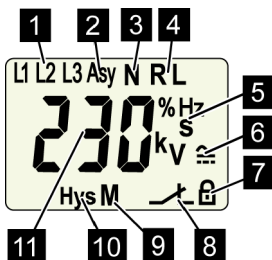
### 5.3 Getting to know keys and key functions

The following table shows the function of the keys for navigation on the display, navigation through the menu and parameter setting. From "Kapitel 5.4 Query values" onwards, only the respective key symbols are used for querying values.







Key	Key symbol	Function
UP		<ul style="list-style-type: none"> <li>• Call up the next display</li> <li>• Move to the next menu, sub menu or category</li> <li>• Activate parameters</li> <li>• Change the parameter value (increase)</li> <li>• Keep the key pressed for more than 1.5 seconds: Carry out the manual self test.</li> </ul>
DOWN		<ul style="list-style-type: none"> <li>• Call up the next display</li> <li>• Move to the next menu, sub menu</li> <li>• Deactivate parameters</li> <li>• Change parameters (decrease)</li> <li>• Keep key pressed for more than 1.5 seconds: Clear fault memory.</li> </ul>
ENTER		<ul style="list-style-type: none"> <li>• Call up menu, submenu.</li> <li>• Save changed parameter value.</li> <li>• Keep key pressed for more than 1.5 seconds: Call up/leave the menu/ move to the next higher submenu item.</li> </ul>



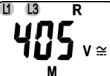

## 5.4 Query values

By default, the display shows the phase-to-phase voltage between L1 and L2. By pressing the UP and DOWN key, the phase-to-phase voltage between L1 and L3, L2 and L3 as well as asymmetry, system frequency and phase sequence can be queried..

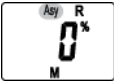

*The flashing elements in the display indications below are highlighted as grey-shaded fields.*

Query	Display indication
1. Query phase-to-phase voltage L1/L2	
2. Change display indication	
3. Query phase-to-phase voltage L2/L3	
4. Change display indication	
5. Query phase-to-phase voltage L1/L3	
6. Change display indication	

Query	Display indication
7. Query asymmetry	
8. Change display indication	
9. Query system frequency	
10. Change display indication	
11. Query phase sequence	

## 5.5 Starting the manual self test

The self test described in "Kapitel 3.2.2 Automatic self test" can also be started manually. During the self test, internal functional faults are detected and are indicated as error codes on the display. The alarm relays are not checked during this test.

In order to start the self test manually:

1. Keep the test button T (UP) pressed for more than 1.5 seconds.



*On the display the text "tes" and all applicable display elements will appear.*

## 5.6 Deactivating fault memory

The device utilises an erasable fault memory.

In order to clear the fault memory:

1. Keep the UP key pressed for more than 1.5 seconds.

## 5.7 Calling up or leaving the menu

In order to call up the menu:

1. Keep the ENTER key pressed for more than 1.5 seconds.

To leave the menu:

1. Keep the ENTER key pressed again for more than 1.5 seconds.

## 5.8 Carrying out settings in the menu

### 5.8.1 Selecting menu items

Press the ENTER key for more than 1.5 seconds to call up the menu. Menu items for different settings are available. Each menu item consists of several submenu items. The UP/DOWN keys can be used to navigate between the menu items. Keep the ENTER key pressed for no longer than 1.5 seconds to call up the menu item. Keep the ENTER key pressed for more than 1.5 seconds to return to the next higher menu level.

Menu item/Key to call up	Description/parameter setting
--------------------------	-------------------------------



Querying and setting response values:

- Undervoltage: < U (AL2)
- Overvoltage: > U (AL1)
- Hysteresis of the voltage response values: Hys U
- Asymmetry: Asy (AL1 and AL2)
- Underfrequency: < Hz (AL1 and AL2)
- Overfrequency: > Hz (AL1 and AL2)
- Hysteresis of the frequency response values: Hys Hz
- Phase sequence: PHS (AL1 and AL2)

Menu item/Key to call up	Description/parameter setting
--------------------------	-------------------------------



1. Press the UP/DOWN key to select the next menu item.



Configuring the fault memory and the alarm relay:

- Activate/deactivate fault memory or select con mode
- Select N/O operation (n.o.) or N/C operation (n.c.) individually for each K1/K2
- After activating the menu item  the LEDs AL1/AL2 indicate arbitrary alarm modes of K1/K2
- Assign the alarm categories undercurrent, overcurrent, underfrequency, overfrequency or device error individually to each K1/K2 (1, r1 / 2, r2).
- Assign the alarm function individually to each K1/K2 (1, r1 / 2, r2) when starting the device



2. Press the UP/DOWN key to select the next menu item.



Set delays:

- Response delay  $t_{on1}/t_{on2}$
- Start-up delay  $t$
- Delay on release  $t_{off}$  (LED, relay)



3. Press the UP/DOWN key to select the next menu item.



Set the parameters for device control





- Select method of measurement 3Ph or 3n
- Enable or disable password protection, change password
- Re-establish factory settings
- Start the preset function PrE manually.
- Service menu SyS blocked



4. Press the UP/DOWN key to select the next menu item.



Query hard and software version















Menu item/Key to call up	Description/parameter setting
	5. Press the UP/DOWN key to select the next menu item.
	Query stored alarm values
	6. Press the UP/DOWN key to select the next menu item.
	Move to the next higher menu level (return)

## 5.8.2 Carrying out settings in the menu item AL

1. Select menu item AL.
2. Carry out parameter change as illustrated below.
3. Keep the ENTER key pressed for more than 1.5 seconds to return to the menu item level after parameter change.

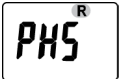





Menu item	Select submenu item	Activate/deactivate parameters	Change display parameter value	Change/save param.
AL				
1. Set the the response value for undervoltage				
2. Select submenu item				
3. Set the response value for overvoltage				
4. Select submenu item				
5. Set the hysteresis for voltage response values				

Menu item	Select submenu item	Activate/deactivate parameters	Change display parameter value	Change/save param.
6. Select submenu item				
7. Set the asymmetry response value				
8. Select submenu item				
9. Set the response value for underfrequency				
10. Select submenu item				
11. Set the response value for overfrequency				
12. Select submenu item				

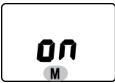
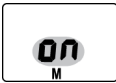
Menu item	Select submenu item	Activate/deactivate parameters	Change display parameter value	Change/save param.
13. Set the hysteresis for frequency response value				
14. Select submenu item				
15. Set the response value for phase sequence				
				
				
16. Select submenu item				
17. Return to menu item AL				

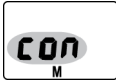
### 5.8.3 Carrying out settings in the menu item out

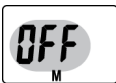
1. Select menu item out.
2. Carry out parameter change as illustrated below.
3. Keep the ENTER key pressed for more than 1.5 seconds to return to the menu item level after parameter change.

Menu item OUT	Select submenu item	Activate/deacti- vate/change par- am.	Change dis- play parame- ter value	Change/save param.
1. Activate/ deactivate fault mem- ory or select con mode		←		←
		▲▼		←
		▲▼		←
2. Reactivate fault mem- ory/select con mode		←		←
		▲▼		←
		▲▼		←

Menu item	Select submenu item	Activate/deactivate/change param.	Change display parameter value	Change/save param.
-----------	---------------------	-----------------------------------	--------------------------------	--------------------

3. Select submenu item



4. Setting the alarm relay K1 to N/C operation (n.c.)

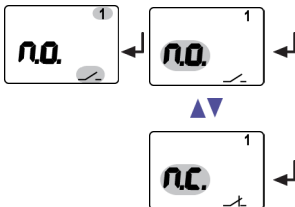

5. Reset alarm relay K1 to N/O operation (n.o.)

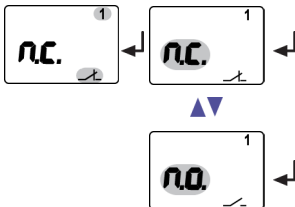

6. Select submenu item





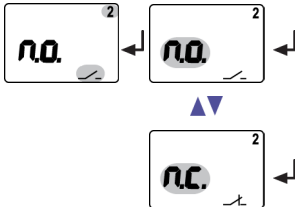









7. Set alarm relay K2 to N/C operation (n.c.)















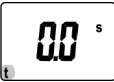

Menu item	Select submenu item	Activate/deactivate/change param.	Change display parameter value	Change/save param.
8. Reset alarm relay K2 to N/O operation (n.o.)				
9. Select submenu item				
10. LEDs AL1/AL2 indicate alarm state of K1/K2				
11. Select submenu item				
12. Assign category device error to alarm relay K1				
13. Change category				
14. Assign undervoltage fault to alarm relay K1				

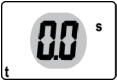
Menu item	Select submenu item	Activate/deactivate/change param.	Change display parameter value	Change/save param.
15. Change category				
16. Assign overvoltage fault to alarm relay K1				
17. Change category				
18. Assign asymmetry fault to alarm relay K1				
19. Change category				
20. Assign underfrequency fault to alarm relay K1				
21. Change category				
22. Assign overfrequency fault to alarm relay K1				
23. Change category				

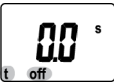
Menu item	Select submenu item	Activate/deactivate/change param.	Change display parameter value	Change/save param.
24. Assign phase sequence fault to alarm relay K1				
25. Change category				
26. Assign undervoltage fault to alarm relay K1				
27. Change category				
28. Return to submenu item r1				
29. Select submenu item				
30. Assign category device error to alarm relay K2			Assignment is carried out in exactly the same way as for alarm relay K1	
31. Select submenu item				
32. Return to menu item out				

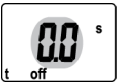





## 5.8.4 Carrying out settings in the menu item t

1. Select menu item t
2. Carry out parameter change as illustrated below.
3. Keep the ENTER key pressed for more than 1.5 seconds to return to the menu item level after parameter change.

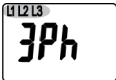
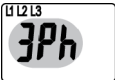
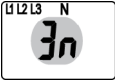
Menu item t	Select submenu item	Activate/deactivate parameters	Change display parameter value	Change/save param.
1. Set response delay K2 (set $t_{on1}$ as $t_{on2}$ )				
2. Select submenu item				
3. Set start-up delay for device start				
4. Select submenu item				
5. Set delay on release K1/K2				
6. Select submenu item				
7. Return to menu item t				

### 5.8.5 Carrying out settings in the menu item SET

1. Select menu item SET.
2. Carry out parameter change as illustrated below.
3. Keep the ENTER key pressed for more than 1.5 seconds to return to the menu item level after parameter change.

Menu item SET	Select submenu item	Activate/deactivate/change param.	Change display parameter value	Change/save param.
1. Set method of measurement for phase				
2. Select submenu item				
3. Enable password protection and enter password (3-digit numerical code)				

Menu item SET	Select submenu item	Activate/deacti- vate/change par- am.	Change dis- play param- eter value	Change/save param.
------------------	------------------------	---	--	-----------------------

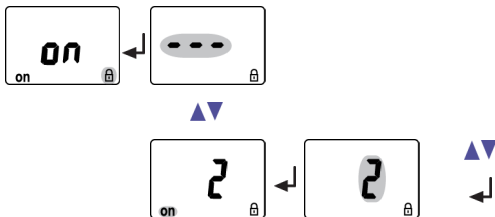
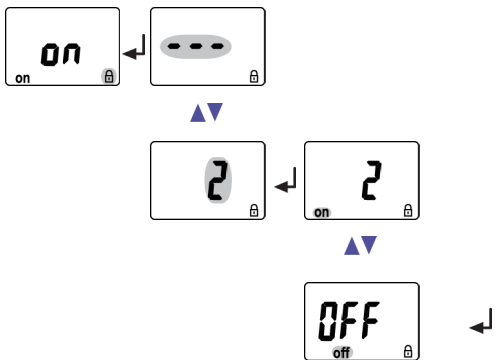
 4. Change pass-  
word

 5. Disable pass-  
word protec-  
tion

 6. Select sub-  
menu item

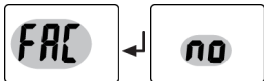
Menu item SET	Select submenu item	Activate/deacti- vate/change par- am.	Change dis- play param- eter value	Change/save param.
------------------	------------------------	---	--	-----------------------

7. Re-establish  
factory set-  
tings



The text "run" will appear on the display and the device will automatically reset to factory setting.



8. Select sub-  
menu item

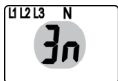
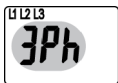
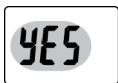

9. Activate pre-  
set function  
for 3Ph and  
3n manually.

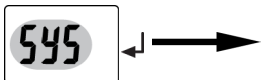
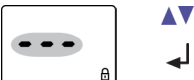

The texts "run" and "PrE" will alternately appear on the display. If the text "rdY" appears on the display, the preset function has been carried out for 3n resp. 3Ph.

Menu item SET	Select submenu item	Activate/deacti- vate/change par- am.	Change dis- play param- eter value	Change/save param.
10. Select sub- menu item				
11. Blocked sys- tem menu				
12. Select sub- menu item				
13. Return to menu item SEt				







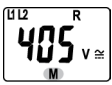

## 5.8.6 Querying information in menu item INF

1. Select menu item INF.

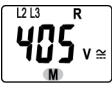
Information such as software version and hardware version will alternately appear on the display. If all the information is displayed, you can select individual information using the UP/DOWN keys.

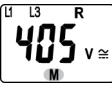
### 5.8.7 Querying and clearing fault memory in the menu item HIS

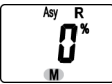
1. Select menu item HIS.
2. Change parameters according to table.
3. Keep the ENTER key pressed for more than 1.5 seconds to return to the menu item level after parameter change.

Menu item HIS	Fault indication /Submenu item
1. Query voltage faults L1/L2	
2. Select fault indication	
3. Query voltage faults L2/L3	
4. Select fault indication	
5. Query voltage faults L1/L3	
6. Select fault indication	
7. Query asymmetry faults	
8. Select fault indication	

## Menu item HIS

Fault indication /Submenu item

9. Query frequency faults

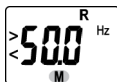

10. Select fault indication



11. Query phase faults

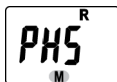

12. Select fault indication



13. Clear fault memory



14. Select fault indication



15. Return to menu item HiS



## 6. Technical data

### 6.1 Data in tabular form

( )\* = factory setting

#### Insulation coordination acc. to IEC 60664-1 / IEC 60664-3

Rated insulation voltage .....	400 V
Rated impulse voltage/pollution degree .....	4 kV/III
Protective separation (reinforced insulation) between . (A1, A2) - (N, L1, L2, L3) - (11, 12, 14) - (21, 22, 24)	
Voltage test acc. to IEC 61010-1:	
(N, L1, L2, L3) - (A1, A2), (11, 12, 14) .....	3.32 kV
(N, L1, L2, L3) - (21, 22, 24) .....	2.21 kV
(A1, A2) - (11, 12, 14) - (21, 22, 24) .....	2.21 kV

#### Supply voltage

VMD420-D-1:

Supply voltage $U_S$ .....	AC 16...72 V / DC 9.6...94 V
Frequency range $f_S$ .....	15...460 Hz

VMD420-D-2:

Supply voltage $U_S$ .....	AC/DC 70...300 V
Frequency range $f_S$ .....	15...460 Hz
Power consumption .....	≤ 3.5 VA

#### Measuring circuit

Measuring range (r.m.s. value) (L-N) .....	AC 0...288 V
Measuring range (r.m.s. value) (L-L) .....	AC 0...500 V
Rated frequency $f_n$ .....	15...460 Hz
Frequency range .....	10...500 Hz**

#### Response values

Type of distribution system .....	3(N) AC / 3 AC (3 AC)*
Undervoltage < U (Alarm 2) (measuring method: 3Ph / 3n) .....	AC 6...500 V / 6...288 V
Overvoltage > U (Alarm 1) (measuring method: 3Ph / 3n) .....	AC 6...500 V / 6...288 V
Resolution of setting U .....	1 V

Preset function for 3 AC measurement:

Undervoltage  $< U$  ( $0.85 U_n$ )\* for  $U_n = 400 \text{ V} / 208 \text{ V}$  ..... 340 V / 177 V

Overvoltage  $> U$  ( $1.1 U_n$ )\* for  $U_n = 400 \text{ V} / 208 \text{ V}$  ..... 440 V / 229 V

Preset function for 3(N)AC measurement:

Undervoltage  $< U$  ( $0.85 U_n$ )\* for  $U_n = 230 \text{ V} / 120 \text{ V}$  ..... 196 V / 102 V

Overvoltage  $> U$  ( $1.1 U_n$ )\* for  $U_n = 230 \text{ V} / 120 \text{ V}$  ..... 253 V / 132 V

Asymmetry ..... 5 ... 30 % (30%)\*

Phase failure ..... by setting of the asymmetry

Phase sequence ..... clockwise/ anticlockwise rotation (off)\*

Relative percentage error, voltage at 50 Hz / 60 Hz .....  $\pm 1.5 \%$ ,  $\pm 2$  digits

Relative percentage error in the voltage range of 15 ... 460 Hz .....  $\pm 3 \%$ ,  $\pm 2$  digits

Hysteresis  $U$  ..... 1 ... 40 % (5%)\*

Underfrequency  $< \text{Hz}$  ..... 10 ... 500 Hz\*\*

Overfrequency  $> \text{Hz}$  ..... 10 ... 500 Hz\*\*

Resolution of setting  $f$  10.0 ... 99.9 Hz ..... 0.1 Hz

Resolution of setting  $f$  100 ... 500 Hz ..... 1 Hz

Preset function:

Underfrequency for  $f_n = 16.7 \text{ Hz} / 50 \text{ Hz} / 60 \text{ Hz} / 400 \text{ Hz}$  ..... 15.7 Hz / 49 Hz / 59 Hz / 399 Hz

Overfrequency for  $f_n = 16.7 \text{ Hz} / 50 \text{ Hz} / 60 \text{ Hz} / 400 \text{ Hz}$  ..... 17.7 Hz / 51 Hz / 61 Hz / 401 Hz

Hysteresis frequency  $\text{Hys Hz}$  ..... 0.1 ... 2 Hz (0.2 Hz)\*

Relative percentage error in the frequency range of 15 Hz ... 460 Hz .....  $\pm 0.2 \%$ ,  $\pm 1$  digits

## Specified time

Start-up delay ..... 0 ... 300 s (0 s)\*

Response delay  $t_{\text{on}1/2}$  ..... 0 ... 300 s (0 s)\*

Release delay  $t_{\text{off}}$  ..... 0 ... 300 s (0.5 s)\*

Resolution of setting  $t$ ,  $t_{\text{on}1/2}$ ,  $t_{\text{off}}$  (0 ... 10 s) ..... 0.1 s

Resolution of setting  $t$ ,  $t_{\text{on}1/2}$ ,  $t_{\text{off}}$  (10 ... 99 s) ..... 1 s

Resolution of setting  $t$ ,  $t_{\text{on}1/2}$ ,  $t_{\text{off}}$  (100 ... 300 s) ..... 10 s

Operating time voltage  $t_{\text{ae}}$  .....  $\leq 140$  ms

Operating time frequency  $t_{\text{ae}}$  .....  $\leq 335$  ms

Response time  $t_{\text{an}}$  .....  $t_{\text{an}} = t_{\text{ae}} + t_{\text{on}1/2}$

Recovery time  $t_{\text{b}}$  ..... 300 ms

## Displays, memory

Display ..... LC display, multi-functional, not illuminated

Display range, measured value .....	AC 0...500 V
Operating error, voltage at 50 Hz / 60 Hz .....	±1.5 %, ±2 digits
Operating error, voltage in the range 15...460 Hz .....	±3 %, ±2 digits
Operating error in the frequency range of 15...460 Hz .....	±0.2 %, ±1 digit
History memory (HiS) for the first alarm value .....	data record measured values
Password .....	Off / 0...999 (OFF/0)*
Fault memory (M) alarm relay .....	on / off / con (on)*

### Switching elements

Number of changeover contacts .....	2 x 1 (K1, K2)
Operating principle .....	N/C operation n.c. / N/O operation n.o.
.....K2: Err, < U, > U, Asy, < Hz, > Hz, PHS, S.AL (undervoltage < U, asymmetry Asy, N/C operation n.c.)*	
.....K1: Err, < U, > U, Asy, < Hz, > Hz, PHS, S.AL (overvoltage >U, asymmetry Asy, N/O operation n.o.)*	
Electrical service life, number of cycles .....	10000
Contact data acc. to IEC 60947-5-1:	
Utilisation category .....	AC 13..... AC 14..... DC-12..... DC-12..... DC-12
Rated operational voltage .....	230 V..... 230 V..... 24 V..... 110 V..... 220 V
Rated operational current .....	5 A..... 3 A..... 1 A..... 0.2 A..... 0.1 A
Minimum contact rating .....	1 mA at AC/DC ≥ 10 V

### Environment / EMC

EMC .....	EN 61326-1
Ambient temperatures:	
Operating temperature .....	-25...+55 °C
Transport .....	-25...+70 °C
Long-term storage .....	-25...+55 °C
Classification of climatic conditions acc. to IEC 60721:	
Stationary use (IEC 60721-3-3) .....	3K5 (no condensation, no formation of ice)
Transport (IEC 60721-3-2) .....	2K3
Long-term storage (IEC 60721-3-1) .....	1K4
Classification of mechanical conditions acc. to IEC 60721:	
Stationary use (IEC 60721-3-3) .....	3M4
Transport (IEC 60721-3-2) .....	2M2
Long-term storage (IEC 60721-3-1) .....	1M3

### Option "W" data different from the standard version

Classification of climatic conditions acc. to IEC 60721:

Stationary use (IEC 60721-3-3) ..... 3K5 (condensation and formation of ice is possible)

Classification of mechanical conditions acc. to IEC 60721:

Stationary use (IEC 60721-3-3) ..... 3M7

## Connection

 Connection ..... **screw-type terminals**

Connection properties:

 rigid/ flexible ..... 0.2...4 / 0.2...2.5 mm<sup>2</sup> / AWG 24...12

Multi-conductor connection (2 conductors with the same cross section):

 rigid, flexible ..... 0.2...1.5 / 0.2...1.5 mm<sup>2</sup>

Stripping length ..... 8...9 mm

Tightening torque ..... 0.5...0.6 Nm

 Connection ..... **push-wire terminals**

Connection properties:

 Rigid ..... 0.2...2.5 mm<sup>2</sup> ( AWG 24...14)

 Flexible without ferrules ..... 0.75...2.5 mm<sup>2</sup> ( AWG 19...14)

 Flexible with ferrules ..... 0.2...1.5 mm<sup>2</sup> ( AWG 24...16)

Stripping length ..... 10 mm

Opening force ..... 50 N

Test opening, diameter ..... 2.1 mm

## General data

Operating mode ..... continuous operation

Mounting ..... any position

Degree of protection, internal components (IEC 60529) ..... IP30

Degree of protection, terminals (IEC 60529) ..... IP20

Enclosure material ..... polycarbonate

Flammability class ..... UL94 V-0

DIN rail mounting acc. to ..... IEC 60715

Screw fixing ..... 2 x M4 with mounting clip

Software version ..... D238 V2.2x

Weight ..... ≤ 150 g

( ) \* = factory setting

\*\* = The technical data only applies to the operating range of the rated frequency (15...460 Hz).

## 6.2 Standards, approvals and certifications



## 6.3 Ordering information

Device type	Nominal system voltage $U_n^*$	Supply voltage $U_s^*$	Art. No.
VMD420-D-1 (push-wire terminals)	3(N)AC 0...500 V/ 288 V 15...460 Hz	AC 16...72 V / DC 9.6 V...94 V DC, 15...460 Hz	B 7301 0005 B 7301 0005W
VMD420-D-1	3(N)AC 0...500 V/ 288 V 15...460 Hz	AC 16...72 V / DC 9.6 V...94 V DC, 15...460 Hz	B 9301 0005 B 9301 0005W
VMD420-D-2 (push-wire terminals)	3(N)AC 0...500 V/ 288 V 15...460 Hz	AC/DC 70...300 V DC, 15...460 Hz	B 7301 0006
VMD420-D-2	3(N)AC 0...500 V/ 288 V 15...460 Hz	AC/DC 70...300 V DC, 15...460 Hz	B 9301 0006
*Absolute values of the voltage range			
Mounting clip for screw fixing (1 piece per device, accessories)			B 9806 0008



# INDEX

## A

- Alarm LEDs show which relay is in the alarm state 19
- Automatic self test 17

## C

- Clear fault memory 33
- currently measured values
  - Asymmetry 31
  - Phase sequence 31
  - phase-to-phase voltage 31
  - rated frequency 31

## D

- Delay on release toff 18

## F

- factory setting 19, 25
- Fast commissioning for  $U_n = 400\text{ V}$  21
- Fault memory in the operating mode on, off or con 17
- Function 15
- Functional faults 17

## G

- Getting 27

## H

- How to use this manual 7

## I

- Indicating of the alarm state of K1/K2 19
- Indication of the alarm state of K1/K2 19
- Installation and connection 21
- Intended use 14

## K

- Key functions 30
- Keys 30

## M

- Manual self test 17, 32
- Menu item AL 36
- Menu item HIS 49
- Menu item INF 48
- Menu item LEd 19
- Menu item OUT 39
- Menu item SET 45
- Menu item t 44
- Menu, call up 33
- Menu, leave 33
- Menu, settings 33
- Mounting clip for screw fixing 55

## O

- Operating elements, function 27
- Operation and setting 27
- Ordering information 55

**P**

Password protection 18

Preset function 16

**Q**

Querying 31

**R**

Response delay ton 18

**S**

S.AL 19

Selecting menu items 33

Service 8

Simulated alarm S.AL 19

Standard display indications 29

Starting a device using a simulated alarm

S.AL 19

Start-up delay t 18

Support 8

**T**

Technical data 51

Time delays 15, 18

Training courses 10

**U**

User interface 27

**W**

Wiring diagram 24

Work activities on electrical installations

13, 15





**Bender GmbH & Co. KG**

P.O. Box 1161 • 35301 Gruenberg • Germany  
Londorfer Strasse 65 • 35305 Gruenberg • Germany  
Tel.: +49 6401 807-0 • Fax: +49 6401 807-259  
E-Mail: [info@bender.de](mailto:info@bender.de) • [www.bender.de](http://www.bender.de)

Photos: Bender archives



**BENDER Group**